

**Operating instructions
Installation information**

METTLER TOLEDO

**METTLER TOLEDO MultiRange
Table and stand scales**

PBA430.../PBA430x...

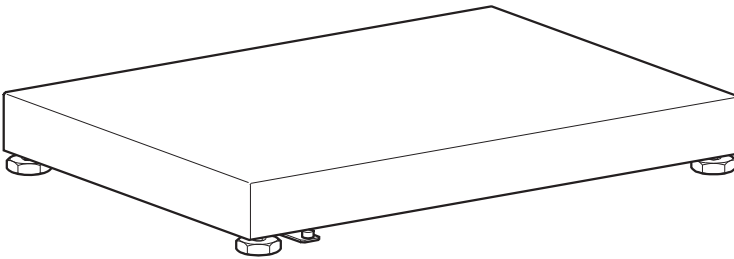

www.mt.com/support

Table of contents

1	Safety precautions	4
2	Setting up the weighing platform	5
2.1	Selecting installation location	5
2.2	Ambient conditions	5
2.3	Levelling	6
2.4	Connecting weighing terminal	6
2.5	Equipotential bonding	6
3	Operating limits	8
4	Cleaning the weighing platform	9
5	Accessories	10
6	Technical data	13
6.1	Technical data of weighing cell 708 / 709	13
6.2	Technical data of terminal box IDNet (optional)	13
6.3	Dimensions	14
7	Disposal	15
8	FCC regulations	15

1 Safety precautions

Product safety plays an important role at METTLER TOLEDO.

Non-observance of the following instructions can lead to damage to the weighing platform and/or injuries.

- ▲ Before using the weighing platform read these instructions. Store these instructions for future use.
- ▲ Take care when transporting or lifting heavy devices.
- ▲ Only personnel trained and qualified by METTLER TOLEDO may install and maintain the weighing platform.
- ▲ Disconnect the weighing terminal from the power supply before carrying out cleaning, installation and maintenance.
- ▲ The weighing platform must have stabilized to room temperature before the supply voltage is switched on.
- ▲ The explosion-protected weighing platforms are approved for operation in the following hazardous areas:
 - PBA430 (analog or IDNet scale interface)
 - Category 3 gas / dust (Zone 2/22)
 - PBA430x (analog scale interface)
 - Category 2 gas / dust (Zone 1/21)
- ▲ There is an increased risk of injury and damage when the weighing platforms are used in hazardous areas! Special care must be taken when working in such hazardous areas. The rules for behaviour are based on the concept of "Safe Distribution" established by METTLER TOLEDO.
- ▲ Explosion-protected weighing platforms may only be used in hazardous areas in conjunction with weighing terminals with the appropriate approval and interface specification.
- ▲ The connection cable may not be disconnected from the weighing terminal while energized.
- ▲ Tighten the knurled nut of the IDNet connecting cable for the optional IDNet scale interface with 10 Nm.
- ▲ In case of PBA430x (analog scale interface) only use cable glands that are suitable and approved for hazardous areas for inserting the weighing cell cable into the service terminal.

2 Setting up the weighing platform

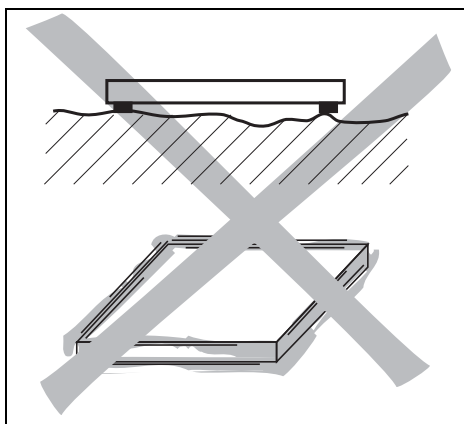

2.1 Selecting installation location

- ▲ The foundation must be capable of safely supporting the weight of the weighing platform at its support points when it carries the maximum load. At the same time, it should be so stable that no vibrations occur during weighing operations. These requirements also apply when the weighing platform is integrated in conveying systems and the like.
- ▲ Ensure that vibrations from machines near the installation site are kept to a minimum.

2.2 Ambient conditions

- ▲ Observe the following ambient conditions:
 - No direct sunshine
 - No strong draught
 - No excessive temperature fluctuations
 - Temperature range -10 °C to $+40\text{ °C}$

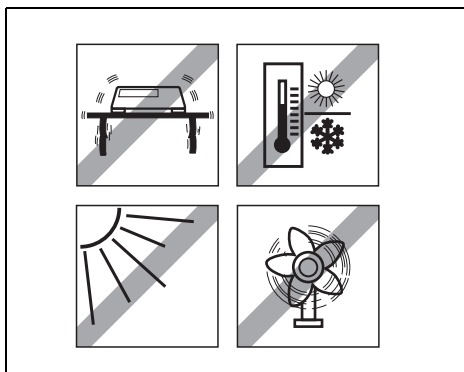

2.3 Levelling

Only a weighing platform which is aligned exactly horizontally supplies exact weighing results.

The weighing platform has to be levelled during the initial installation and whenever its location is changed.

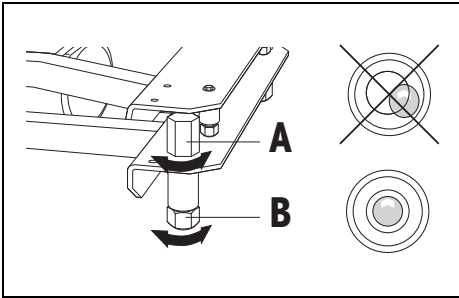

- Lift weighing pan and loosen lock nuts (A) of all levelling feet.
- Turn levelling feet (B) until the weighing platform is supported evenly or the air bubble is found in the centre of the level.
- Firmly tighten lock nuts of all levelling feet with an open-end spanner.
- Set weighing pan back in place.

2.4 Connecting weighing terminal

Terminal	Colour
SIG+ (OUT+)	White
SIG- (OUT-)	Red
EXC+ (IN+)	Green
EXC- (IN-)	Black
SEN+	Blue
SEN-	Brown

The PBA430(x).. weighing platform is intended for use with analog weighing terminals.

- Connect weighing platform to the weighing terminal in accordance with the table shown.

Weighing platforms with optional IDNet interfaces can be connected to all ID or IND weighing terminals with corresponding interface.

2.5 Equipotential bonding

The equipotential bonding must be installed by a professional electrician when using the weighing platform in hazardous areas.

METTLER TOLEDO Service only has a monitoring and consulting function here.

- Connect equipotential bonding (PA) of all devices (weighing platform and service terminal) in accordance with the country-specific regulations and standards. In the process, make sure that all device housings are connected to the same potential via the PA terminals.

For **PBA430** mounting materials are enclosed with the weighing terminals ID...xx or IND...xx.

For **PBA430x** equipotential bonding is mounted in the factory.

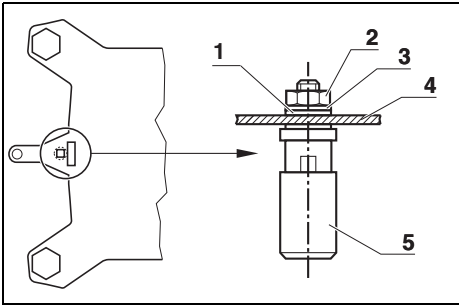

PBA430(x)-A / PBA430(x)-QA

- (1) Serrated lock washer A 4.3 DIN 6798
- (2) Hexagonal lock nut M4 DIN 934
- (3) Washer 4.3 DIN 125
- (4) Base frame
- (5) Equipotential bonding terminal

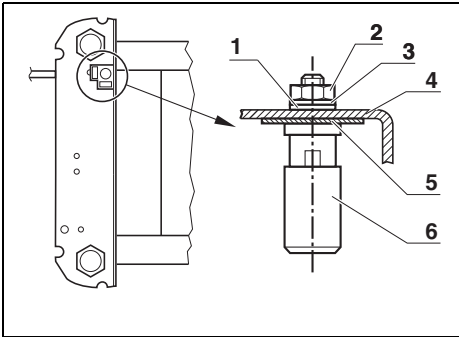

PBA430(x)-B / PBA430(x)-QB / PBA430(x)-QC

- (1) Serrated lock washer A 4.3 DIN 6798
- (2) Hexagonal lock nut M4 DIN 934
- (3) Washer 4.3 DIN 125
- (4) Base frame
- (5) Earthing plate
- (6) Equipotential bonding terminal

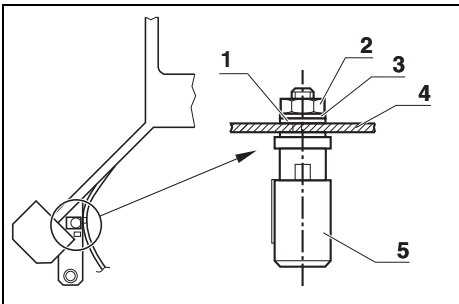

PBA430(x)-CC

- (1) Serrated lock washer A 4.3 DIN 6798
- (2) Hexagonal lock nut M4 DIN 934
- (3) Washer 4.3 DIN 125
- (4) Base frame
- (5) Equipotential bonding terminal

3 Operating limits

The weighing platform has such a rugged design that no damage should result if the maximum weighing capacity is occasionally exceeded.

The static load-bearing capacity, i.e. the maximum permissible load, is dependent on the type of loading (positions A–C). The maximum static load-bearing capacity may not be exceeded.

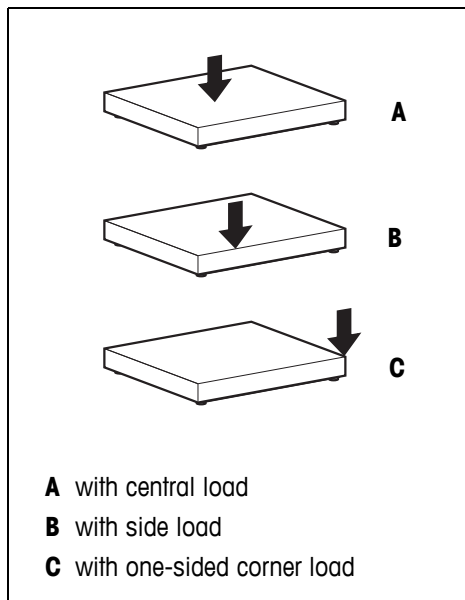

Maximum permissible load

PBA430(x)	A	B	C
-A...	30 kg	20 kg	10 kg
-BB...	100 kg	70 kg	35 kg
-B...	200 kg	140 kg	75 kg
-BC...	400 kg	300 kg	150 kg
-CC...	700 kg	400 kg	200 kg
-QA...	15 kg	10 kg	5 kg
-QB...	100 kg	70 kg	35 kg
-QC...	200 kg	140 kg	75 kg

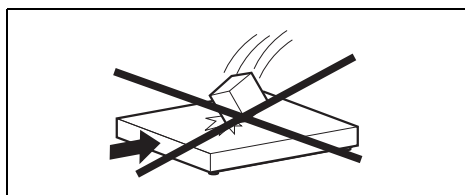

▲ Falling loads, shocks and lateral impacts must be avoided.

4 Cleaning the weighing platform

Maintenance of the weighing platform is limited to regular cleaning. The procedure depends on the ambient conditions prevalent at the installation site.

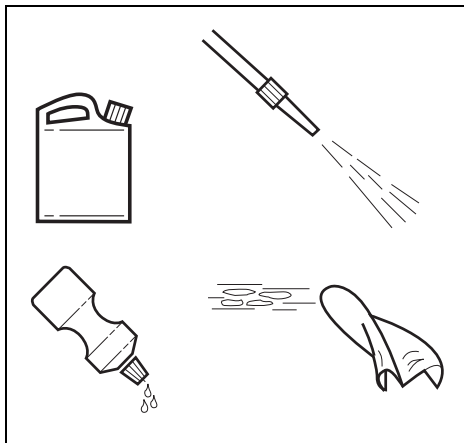

Wet surroundings

- Dirt, deposits and substances causing corrosion must be removed regularly.
- Water jet up to 85 °C, max. water pressure 8,000 kPa, minimum distance 40 cm.
- Only use disinfectants and cleaning agents in accordance with the manufacturer's specifications and instructions and then rinse with clean water.
- Dry off the weighing platforms with a soft, lint-free cloth immediately after cleaning.
- Treat with universal oil.

5 Accessories

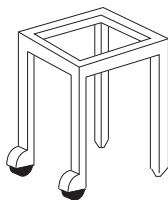

Stand

rigid frame construction
 2 feet with casters
 one fixed foot with screw
 adjustment
 height approx. 560 mm

for PBA430(x)-B 400 x 500 mm	00 503 632
---------------------------------	------------

for PBA430(x)-CC 600 x 800 mm	00 504 854
----------------------------------	------------

Roller track

lengthwise motion

hot-galvanised
 for dry surroundings
 conductive rollers
 (for hazardous areas)

for PBA430(x)-B 400 x 500 mm	00 503 640
---------------------------------	------------

for PBA430(x)-BC 500 x 650 mm	22 012 638
----------------------------------	------------

for PBA430(x)-CC 600 x 800 mm	00 504 852
----------------------------------	------------

stainless steel
 for wet surroundings
 rollers not conductive

for PBA430-B 400 x 500 mm	22 001 647
------------------------------	------------

for PBA430-BC 500 x 650 mm	22 012 799
-------------------------------	------------

for PBA430-CC 600 x 800 mm	22 001 648
-------------------------------	------------

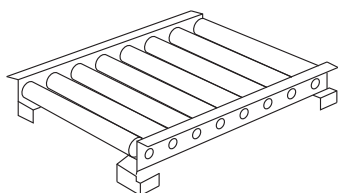

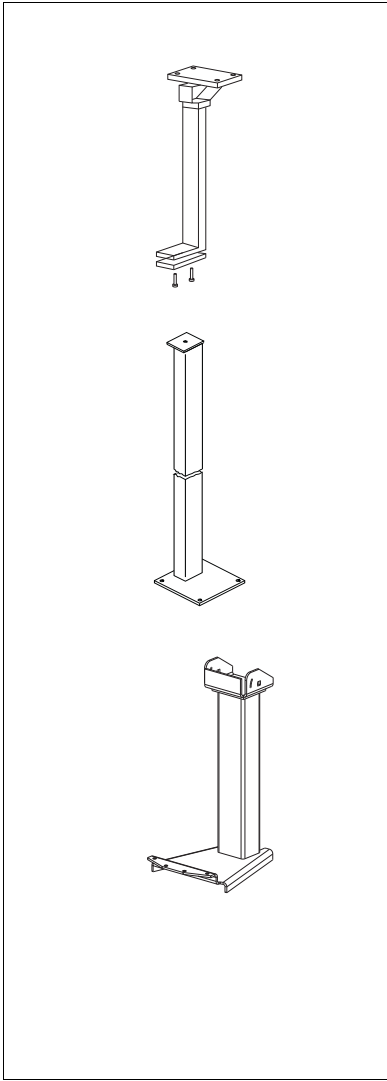

Part No.

Pillar support

for the fastening of the terminal to the stand
incl. fastenings
stainless steel
for ID terminal

00 504 128

Floor stand

incl. fastenings
stainless steel
for ID terminal
for IND4x9 terminal
for IND690 terminal

00 504 132

22 014 834

22 011 981

Stand base, stainless steel

00 503 701

Scale stand

for fastening the terminal to the weighing platform, stainless steel

Height 330 mm

for ID terminal 22 010 334

for Panther terminal 22 010 332

for IND4x9 terminal 22 013 964

Height 660 mm

for ID terminal 22 010 335

for Panther terminal 22 010 333

for IND4x9 terminal 22 013 965

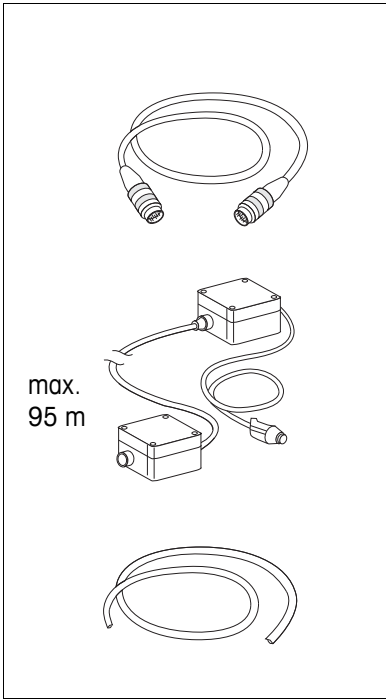

Part No.

Extension cable

00 504 134

length 10 m, connector at both ends
for remote setup of ID terminal

Cable adapter kit for ID terminals 00 504 133

for extending connection cable to 100 m
comprising two junction boxes
box at terminal end with connection cable of 2.5 m length

Special cable from the roll 00 504 177

100 m, used with adapter kit for ID terminals for extension of connection cable to required length

6 Technical data

6.1 Technical data of weighing cell 708 / 709

ATEX Ignition protection type	II 2G Ex ia IIC T6/T5 Gb -40 °C ≤ T _q ≤ +45 °C/+60 °C II 2D Ex ia IIIC IP67 T100°C Db BVS 10 ATEX E 098
FM-Approvals	IS Class I, II, III Div. 1 Group A, B, C, D, E, F, G / T4 / T _q = 40 °C Control Drawing 22015627
IP protection type	IP68 / IP69k

Characteristics

Sensitivity	708-11 kg, 708-22 kg	2.2 mV/V +/- 5 %
	other weighing cells	2.0 mV/V +/- 5 %
Input resistance	1,100 Ω +/- 50 Ω	
Output resistance	960 Ω +/- 50 Ω	
Supply, max.	15 V	

6.2 Technical data of terminal box IDNet (optional)

Ignition protection type	II 3G Ex nA II T4 -10 °C ≤ T _q ≤ +40 °C II 3D Ex tD A22 IP67 T 75 °C BVS 06 ATEX E 098
IP protection type	IP67

6.3 Dimensions

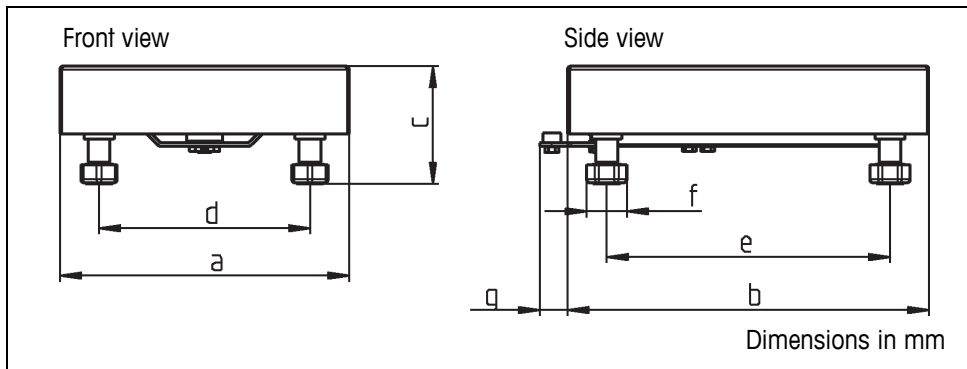

Platform size	a	b	c ¹⁾	d	e	f ²⁾	g
240 x 300 mm	240	300	95	175	235	30/34	22
300 x 400 mm	300	400	97	235	335	30/34	15
400 x 500 mm	400	500	100	335	435	30/34	15
500 x 650 mm	500	650	108	435	587	30/34	15
600 x 800 mm	600	800	130	503	724	30/34	21
229 x 229 mm	229	229	95	170	170	30/34	22
305 x 305 mm	305	305	97	233	245	30/34	15
457 x 457 mm	457	457	100	392	397	30/34	15

1) Min. height = c, max. height = c + 15 mm

2) Circle diameter / diagonal

1 mm ≈ 0.0394 inch

1 inch ≈ 25.4 mm

7 Disposal



In conformance with the European Directive 2002/96/EC on Waste Electrical and Electronic Equipment (WEEE), this device may not be disposed of in domestic waste. This also applies to countries outside the EU as per their specific regulations.

→ Please dispose of this product in accordance with local regulations at the collecting point specified for electrical and electronic equipment.

If you have any questions, please contact the responsible authority or the distributor from which you purchased this device.

Should this device be passed on to other parties (for private or professional use), the content of this regulation must also be related.

Thank you for your contribution to environmental protection.

8 FCC regulations

This equipment has been tested and found to comply with the limits for a Class A digital device, pursuant to both Part 15 of the FCC Rules and the radio interference regulations of the Canadian Department of Communications. These limits are designed to provide a reasonable protection against harmful interference when the equipment is operated in a commercial environment. This equipment generates, uses and can radiate radio frequency energy and, if not installed and used in accordance with the user manual, may cause harmful interference to radio communications. Operation of this equipment in a residential area is likely to cause harmful interference, in which case the user will be required to correct the interference at his own expense.

ServiceXXL

Tailored Services

METTLER TOLEDO products stand for highest quality and precision. Careful handling in accordance with these operating instructions as well as regular maintenance and inspection by our professional customer service ensure the long and reliable function and maintenance of value of your measuring instruments. Our experienced service team will be pleased to inform you about corresponding service agreements or calibration services.

Please register your new product under www.mt.com/productregistration, so that we can inform you about improvements, updates and further important information about your METTLER TOLEDO product.



22010231D

Subject to technical changes © Mettler-Toledo (Albstadt) GmbH 01/11 Printed in Germany 22010231D

Mettler-Toledo (Albstadt) GmbH

D-72458 Albstadt

Tel. ++49-7431-14 0, Fax ++49-7431-14 232

Internet: <http://www.mt.com>