

**Operating Instructions
Installation Information**

METTLER TOLEDO

**METTLER TOLEDO MultiRange
Weighing Platforms
PUA574 / PUA579(x) / PUA579(x)mobile**

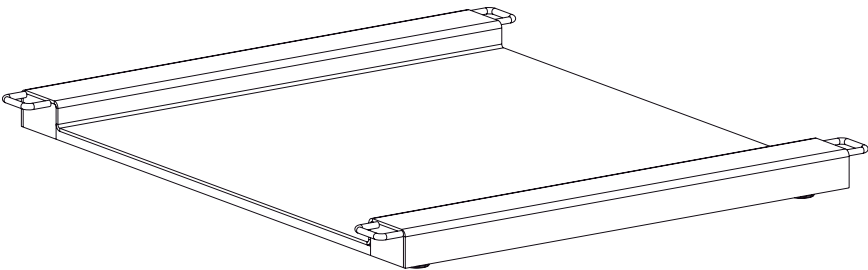
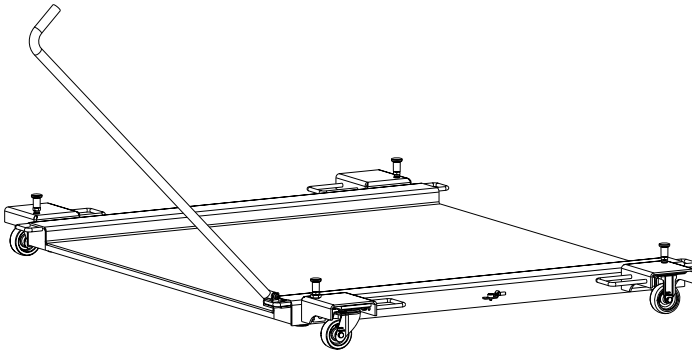

www.mt.com/support

Content

1	General information	4
2	Safety instructions	4
2.1	Safety instructions for PUA574	4
2.2	Safety instructions for PUA579(x)(mobile)	4
3	Selecting the installation location	6
4	Equipotential bonding (for categories 2/3)	7
5	Ignition protection type PUA579(x)(mobile)	8
6	Setting up the stationary variant PUA57.(x)	9
6.1	Above-ground installation with access ramp or base plates	9
6.2	Above-floor installation with installation frame	10
6.3	Mounting the passage stop	11
7	Instructions for the mobile variant PUA579(x)mobile	12
7.1	Safety instructions	12
7.2	Fastening the drawbar	13
7.3	Fastening the stand	14
7.4	Establishing the moving mode	15
7.5	Placing the weighing platform	16
7.6	Establishing the weighing mode	18
8	Commissioning	19
9	Operating limits	20
10	Scales configuration	21
11	Dimensions	22
12	Cleaning the weighing platform	24
12.1	Cleaning agents	24
12.2	Cleaning in a dry environment	24
12.3	Cleaning the exterior (weighing platform standing on the floor)	24
12.4	Cleaning from below (in conjunction with a lifting system)	25
12.5	Subsequent treatment	25
13	Standard accessories	26
14	Disposal	30

1 General information

This operating and installation manual contains all the information on the installation, commissioning and operation of the following weighing platforms.

- PUA574 as a coated design
- PUA579(mobile) as a stainless version approved for use in hazardous areas of Zones 2/22
- PUA579x(mobile) as a stainless version approved for use in hazardous areas of Zones 1/21

The weighing platforms are available with an analog scales interface or a digital IDNet scales interface.

Information about the maintenance, troubleshooting and repairs are contained in the Service Manual ME-22014210.

2 Safety instructions

2.1 Safety instructions for PUA574

- ▲ Do not use the weighing platform in hazardous areas!

2.2 Safety instructions for PUA579(x)(mobile)



There is an increased risk of injury and damage when the weighing platforms are used in hazardous areas! Special care must be taken when working in such hazardous areas. The rules for behaviour are based on the concept of "Safe Distribution" established by METTLER TOLEDO.

Competence

- ▲ The weighing platforms PUA579(x)(mobile) may only be installed, maintained and repaired by authorised METTLER TOLEDO service personnel.

Ex approval

- ▲ No modifications may be made to the device and no repair work may be performed on the modules. Any weighing cells or system modules that are used must comply with the specifications contained in the installation instructions. Non-compliant equipment jeopardises the intrinsic safety of the system, cancels the Ex approval and renders any warranty or product liability claims null and void.
- ▲ The safety of the weighing system is only guaranteed when the weighing system is operated, installed and maintained in accordance with the respective instructions.

- ▲ Also comply with the following:
 - the instructions for the system modules and weighing cells
 - the regulations and standards in the respective country
 - the applicable statutory requirements for electrical equipment installed in hazardous atmospheres in the respective country
 - all instructions related to safety issued by the owner
- ▲ The explosion-protected weighing system must be checked to ensure compliance with the requirements for safety before being put into service for the first time, following any service work and every 3 years, at least.
- ▲ If a replacement part is used, mark the load cells 0745A permanently for the respective operating location (Category 2GD or Category 3GD)

Operation

- ▲ Prevent the build-up of static electricity. Always wear suitable working clothes when operating or performing service work in a hazardous area.
- ▲ Do not use protective coverings for the devices.
- ▲ Avoid damage to the system components.

Installation

- ▲ Only install and perform maintenance work on the weighing system in the hazardous areas if the following conditions are fulfilled
 - if the intrinsically safe characteristic values and zone approval of the individual components are in accord with one another
 - the owner has issued a permit ("spark permit" or "fire permit")
 - the area has been rendered safe and the owner's safety co-ordinator has confirmed that there is no danger
 - the necessary tools and any required protective clothing are provided (danger of the build-up of static electricity)
- ▲ The certification papers (certificates, manufacturer's declarations) must be present.
- ▲ Lay cables in such a way that they are protected from damage.
- ▲ Only route cables into the housing of the system modules via the suitable cable coupler and ensure proper seating of the seals.

Additional requirements for Category 3 (Zone 2/22)

- ▲ The explosion-protected weighing platform PUA579(mobile) may only be operated in Zone 2 and 22 hazardous areas in conjunction with weighing terminals that have a corresponding approval and interface specification.
- ▲ The connection cable may not be separated from the weighing terminal while it is energised.
- ▲ Tighten the knurled nut of the IDNet connecting cable with 10 Nm.

3 Selecting the installation location

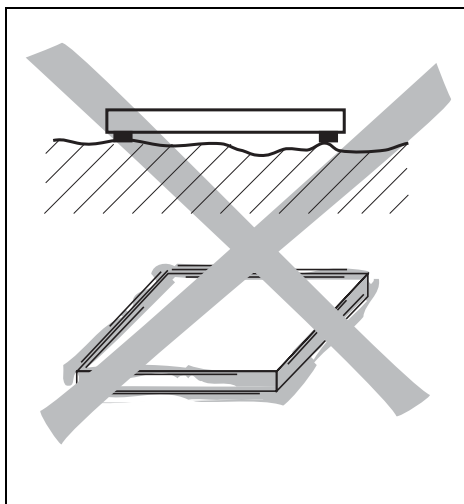

- ▲ The foundation at the installation location must be capable of safely support the weight of the weighing platform at its support points when it carries the maximum load. At the same time it should be so stable that no vibrations arise during weighing work. These requirements also apply when the weighing platform is integrated in conveying systems and the like.
- ▲ Ensure that vibrations from machines near the installation site are kept to a minimum.

Ambient conditions PUA574

→ Use the weighing platform only in a dry environment.

Ambient conditions PUA579(x)(mobile)

→ Use the weighing platform in a dry environment or in a humid environment.

4 Equipotential bonding (for categories 2/3)

The equipotential bonding must be installed by a professional electrician when using the weighing platforms PUA579(x)(mobile) in hazardous areas. METTLER TOLEDO Service only has a monitoring and consulting function here.

▲ The equipotential bonding terminal must always be connected in weighing mode!

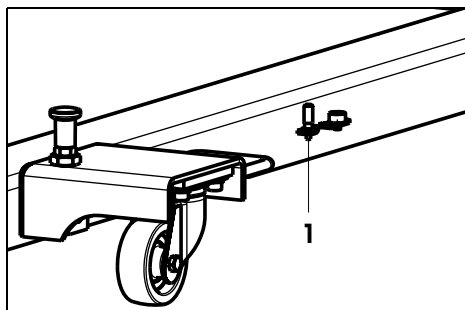

- At the PUA579(x) weighing platforms the equipotential bonding terminal is located at the terminal box of the weighing platform.
- At PUA579(x)mobile the equipotential bonding terminal (1) is located next to the level indicator on the outside of the weighing platform.

→ Connect equipotential bonding (PA) of all devices (weighing platform, service terminal) in accordance with the country-specific regulations and standards. In the process, make sure that all device housings are connected to the same potential via the PA terminals.



EXPLOSION HAZARD

- ▲ If vessels for filling or emptying are located on the weighing platform in a hazardous area, these have to be earthed separately by means of a suitable equipotential bonding.

5 Ignition protection type PUA579(x)(mobile)

	Category 3	Category 2
Load cells	Load cell 0745A II 3G Ex nA II T4 II 3G Ex nL IIC T4 $-40\text{ °C} \leq T_a \leq +50\text{ °C}$ II 3D Ex tD A22 IP6X T 100 °C KEMA 03 ATEX 1070	Load cell 0745A II 2G Ex ia IIC T4 $-40\text{ °C} \leq T_a \leq +50\text{ °C}$ II 2D Ex tD A21 IP68X T 100 °C KEMA 03 ATEX 1069
Analog scale interface	System solution Analog Ex2 II 3G Ex nA II T4 $-20\text{ °C} \leq T_a \leq +60\text{ °C}$ II 3D Ex tD A22 IP65 T 75 °C BVS 08 ATEX E 063	Analog Ex1 II 2G Ex ia IIC T4 $-20\text{ °C} \leq T_a \leq +60\text{ °C}$ II 2D Ex tD A21 IP68 T 75 °C BVS 04 ATEX E221
	System component Analog Ex2 II 3G Ex nA II T4 $-20\text{ °C} \leq T_a \leq +60\text{ °C}$ II 3D Ex tD A22 IP68 T 75 °C BVS 08 ATEX E 063	
Digital scale interface (IDNet)	System solution type Point II 3G Ex nA II T4 $-10\text{ °C} \leq T_a \leq +40\text{ °C}$ II 3D Ex tD A22 IP67 T 75 °C BVS 06 ATEX 098	Point Ex II 2G Ex ia IIC T4 Gb $-20\text{ °C} \leq T_a \leq +60\text{ °C}$ II 2D Ex tb IIIC IP67 T 75 °C Db BVS 03 ATEX E 432

6 Setting up the stationary variant PUA57.(x)

Note

For a **verifiable application** the weighing platform has to be fastened to the floor as shown with access ramp(s) and/or base plates or with the installation frame.

For a **non-verifiable application** the weighing platform can also be operated without fastening to the floor with access ramp(s) and/or base plates or with the installation frame.

6.1 Above-ground installation with access ramp or base plates

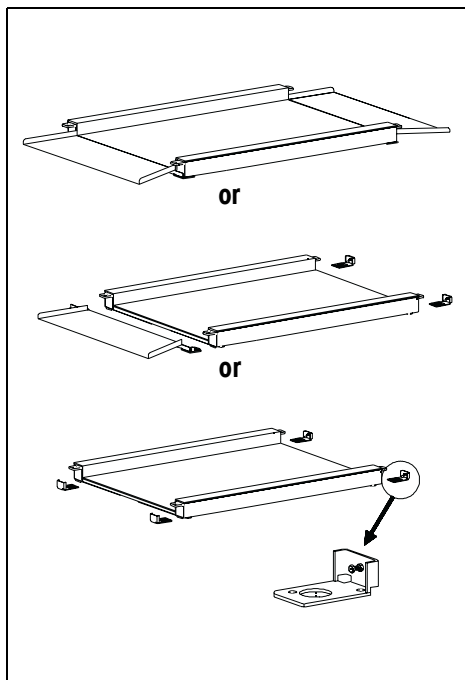

1. Place access ramp(s) and/or base plates on the even floor in front of and behind the weighing platform at a suitable location.
2. Lift the weighing platform at the handles and place it with the levelling feet into the provided recesses of the ramps or base plates.
3. Ensure levelness in the area of the scales bases. If applicable, level using adjustable levelling feet.
4. Align the ramps and base plates.
5. Mark the position of the ramps and base plates and dowel them into the floor using the supplied dowels (2 dowels each per ramp or base plate).
6. Set the screws for vibration limitation at the base plates to 2–3 mm play.

6.2 Above-floor installation with installation frame

In non-verification operation

Note

This installation is only suitable for use with hand pallet trucks or roll containers. Other uses may cause the weighing platform to be displaced.

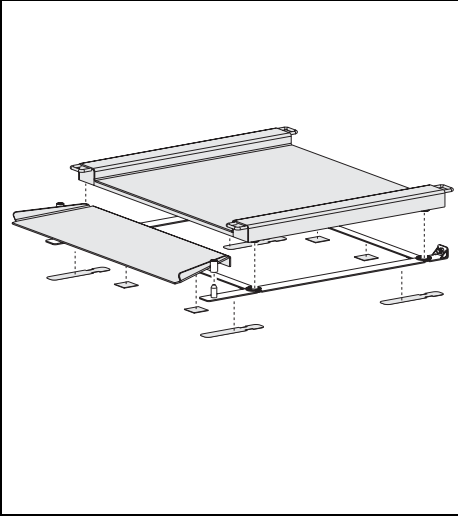

1. Apply the anti-slip rubbers to the bottom of the installation frame. Ensure that the ground is clean and free of oil.
2. Assemble the installation frame as shown in the enclosed assembly instructions.
3. Set up the installation frame at a suitable location with a level ground.
4. Insert the weighing platform in the installation frame and level using the adjustable levelling feet.
5. If appropriate, place the ramp(s) on.
6. If you use a ramp, set the screw for vibration limitation to 2–3 mm play.

In verification operation

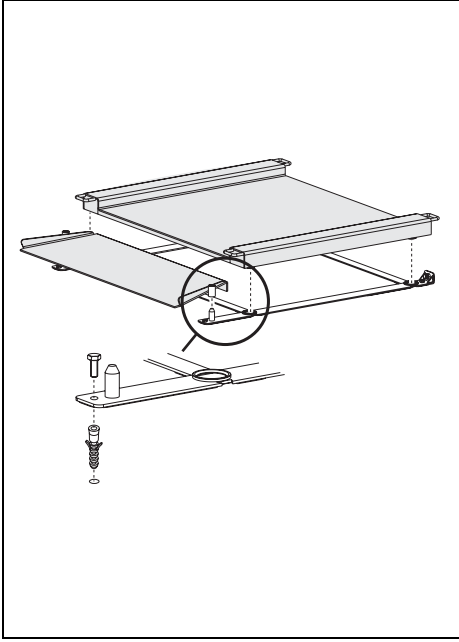

1. Assemble the installation frame as shown in the enclosed assembly instructions.
2. Set up the installation frame at a suitable location with a level ground. Do not attach the anti-slip rubbers!
3. Mark the drill position for the anchor bolt plugs.
4. Drill the plug holes and suck off the dirt.
5. Fasten the installation frame to the floor using heavy-duty anchor plugs.
6. Insert the weighing platform in the installation frame and level using the adjustable levelling feet.
7. If appropriate, place the ramp(s) on.
8. If you use a ramp, set the screw for vibration limitation to 2–3 mm play.

6.3 Mounting the passage stop

Note

The passage stop cannot be used together with the lifting system!

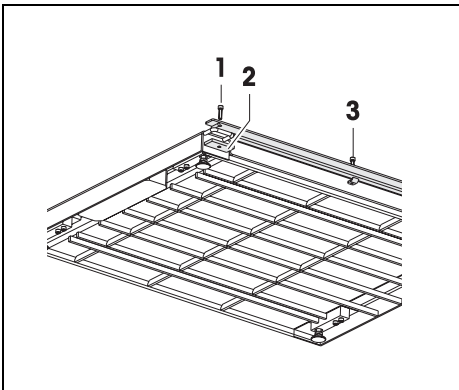

1. Mount the passage stop using the two outer screws (1) and the two lugs (2) to the handles of the weighing platform.
2. Screw the centre screw (3) into the thread until it contacts the load plate. This prevents the passage stop from bending when force is applied from above (step protection).

7 Instructions for the mobile variant PUA579(x)mobile

7.1 Safety instructions



WARNING

Danger of crushing!

- ▲ Operation only by instructed personnel.
- ▲ Operation only from the side.
- ▲ Operation of the roller boxes only with both hands.

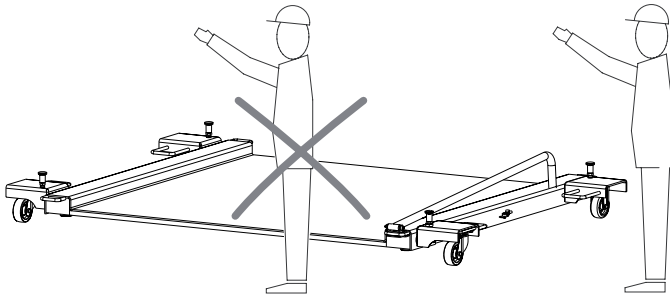

CAUTION

Damage to and/or malfunction of the weighing platform!

- ▲ Weighing samples or other loads are not permitted on the weighing platform while moving it.
- ▲ Put on weighing samples only in weighing mode.

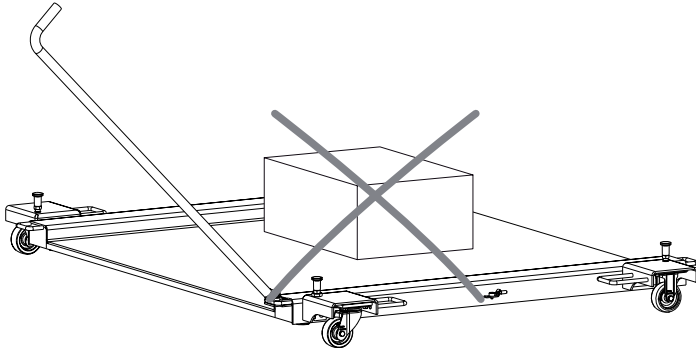

7.2 Fastening the drawbar

The drawbar included in the scope of delivery can be fastened at the handle on the left- or right-hand side of the weighing platform.

▲ Ensure that both moving rollers are located at the front (facing the drawbar).

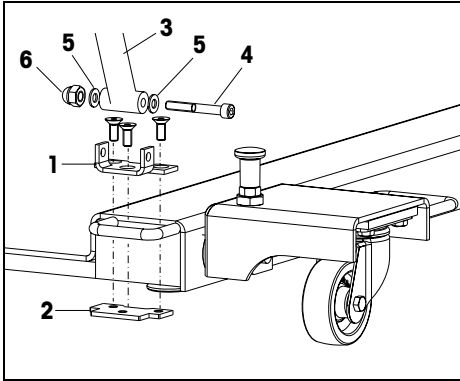

1. Lay the bracket (1) from above into the clamp and screw it to the plate (2).
2. Hook the drawbar (3) into the bracket and fasten it using the long screw (4), washers (5) and cap nut (6).

7.3 Fastening the stand

An adapter plate is available as an accessory to fasten a standard floor stand.

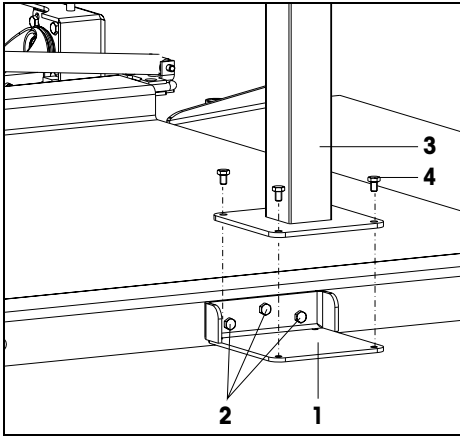

1. Fasten the adapter plate (1) for stand fastening at the side with 3 screws (2) to the weighing platform.
2. Fasten the standard floor stand (3) to the adapter plate using the corresponding terminal adapter with 4 screws (4).
3. Lay the connecting cable under the weighing platform and tie to the stand adapter using cable ties.
4. Lay the cable in the stand and connect to the weighing terminal.



CAUTION

Damage to and/or malfunction of the weighing platform!

- ▲ Ensure that the connection cable does not touch the floor.
- ▲ Use only the drawbar (1) to pull or push the unit in moving mode. Under no circumstances pull or push at the stand (2).

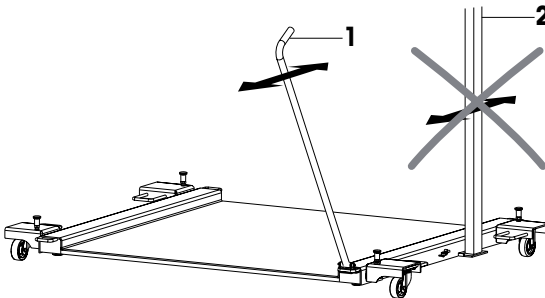

7.4 Establishing the moving mode

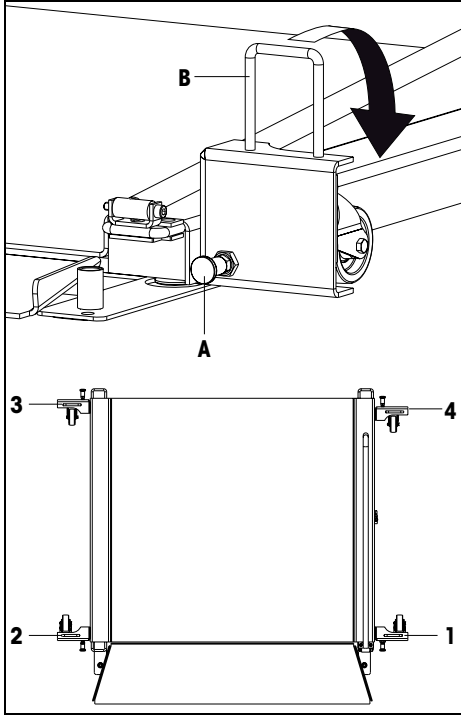

1. Start at Roller box 1 (moving roller).
2. Unbolt the lock (A) with one hand and keep it pulled out. Use the other hand to fold the lever (B) downwards until the lock latches in again.
3. Proceed at Roller boxes 2 to 4 as described under Item 2.

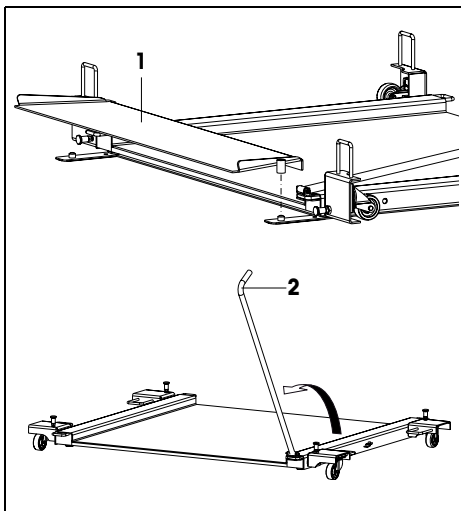

4. Hang out the access ramp (1) and put aside or respectively pull out the Rampfix under the weighing platform.
5. Fold out the drawbar (2) forwards and move the scale.

7.5 Placing the weighing platform

Placing with installation frame

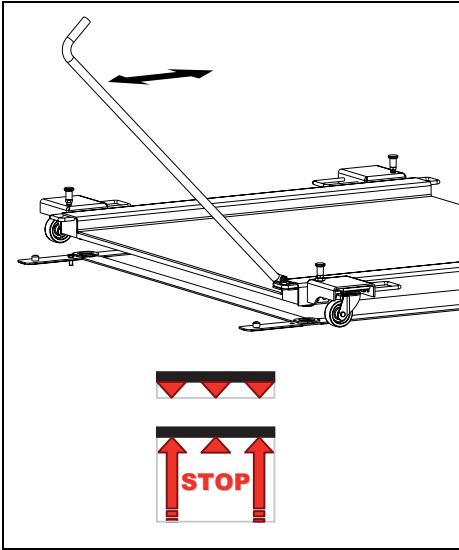

1. Mount the installation frame, see Section 6.2.
2. At the initial installation apply the supplied STOP label to the installation frame.
3. Push the weighing platform over the installation frame until the STOP marking is reached.

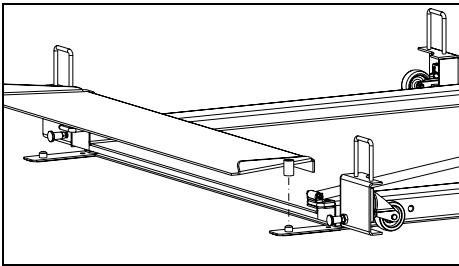

4. Hang in the access ramp.

Placing with the Rampfix ramp fastener

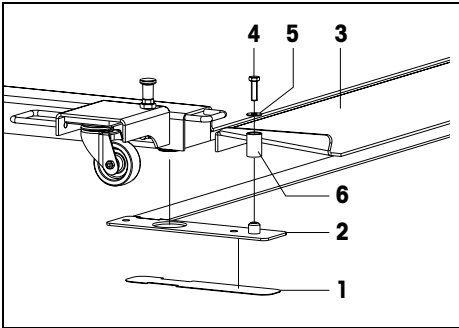

Preparing the Rampfix

1. Apply the anti-slip rubbers (1) to the bottom of the Rampfix (2). Ensure that the underground is clean and free of oil.
2. Screw the ramp (3) to the Rampfix using the screw (4), washer (5) and sleeve (6).

Placing the weighing platform

1. Slide the PUA579(x)mobile to the desired position.
2. Push the Rampfix with ramp under the weighing platform.
3. Align the Rampfix to the STOP marking.

▲ Use the PUA579(x)mobile only with the supplied levelling foot rubbers.

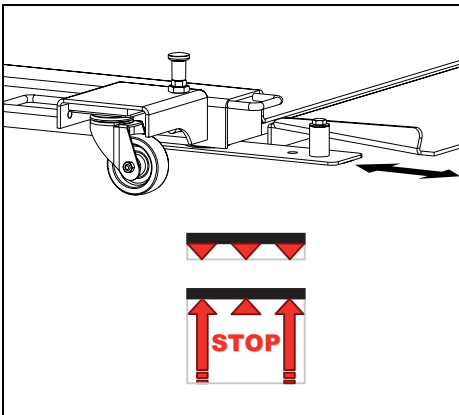

7.6 Establishing the weighing mode

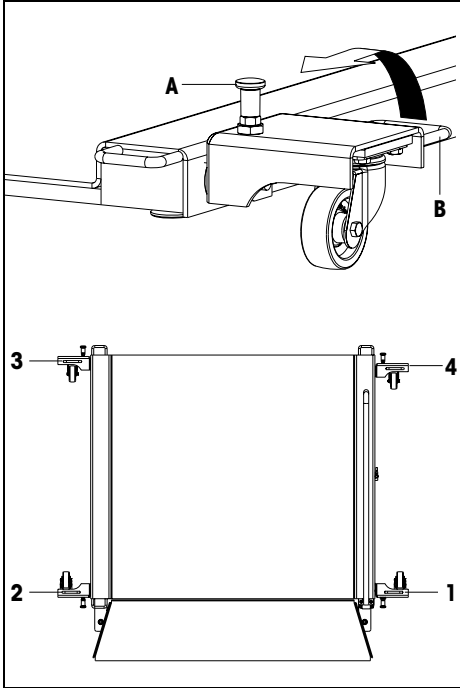

1. Fold the drawbar downwards onto the weighing platform.
2. Start at Roller box 4.
3. Unbolt the lock (A) with one hand and keep it pulled out. Use the other hand to fold the lever (B) upwards until the lock latches in again.
4. Proceed at Roller boxes 3 to 1 as described under Item 3.
5. Check whether the weighing platform is positioned correctly.
6. Check the level of the weighing platform.

8 Commissioning

Weighing platforms with analog scales interface

Terminal	Standard	Ex
EXC+ (IN+)	grey	grey
SEN+	yellow	yellow
SIG+ (OUT+)	white	white
SIG- (OUT-)	brown	brown
SEN-	green	green
EXC- (IN-)	blue	pink

Weighing platforms with an analog scales interface can be connected to weighing terminals with an integrated A/D converter.

- Connect the weighing platform to the weighing terminal in accordance with the adjacent table.
- Route the connecting cable so that it is protected from damage.

Weighing platforms with IDNet interface

Weighing platforms with an IDNet interface can be connected to all weighing terminals with an IDNet connection.

- Route the connecting cable so that it is protected from damage.

9 Operating limits

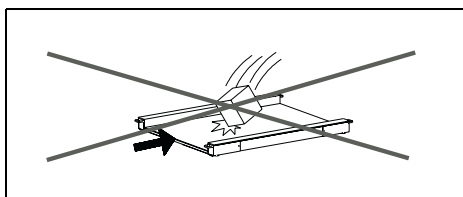
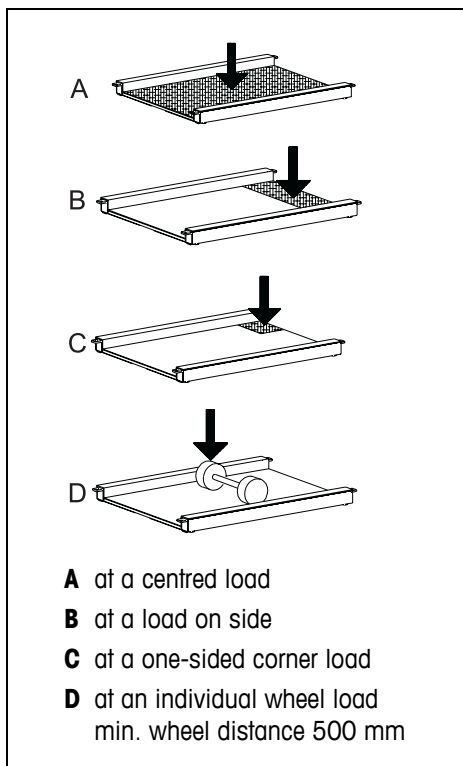

Operation with access ramps

- The load plate of the weighing platform is an active weighing component. The access ramps are passive. This means that during the weighing process all the wheels of the transport vehicles have to be on the load plate.
- The air gap between the load plate and the access ramps has to be free. The gap should therefore be inspected regularly and kept free, in particular during the weighing of granular or small-scale material.

The weighing platforms are designed extremely robustly. However, the load limits in the following table should not be exceeded.

Depending on the type of load bearing, the static bearing, i.e. the maximum permissible load, amounts to:

Maximum permissible load

	PUA57..CS PUA57..FL	PUA57..E PUA57..FM	PUA57..FH
A	800 kg	1850 kg	3000 kg
B	400 kg	900 kg	1800 kg
C	300 kg	450 kg	900 kg
D	200 kg	400 kg	800 kg

→ Avoid falling loads, shock loads as well as impacts from the side.

10 Scales configuration

At the factory the scales are configured with a resolution of 1 x 3000 e (standard). The corresponding measuring data sign has to be provided to the ID card.

Possible configurations

Weighing platform	Maximum load	Standard		Options	
		1 x 3000 e	2 x 3000 e MR/MI *	3 x 3000 e MR *	1 x 6000 e
PUA57..CS/FL	300 kg	0.1 kg	0.05 / 0.1 kg	–	0.05 kg
	600 kg	0.2 kg	0.1 / 0.2 kg	–	0.1 kg
PUA57..E/FM	300 kg	0.1 kg	0.05 / 0.1 kg	–	0.05 kg
	600 kg	0.2 kg	0.1 / 0.2 kg	–	0.1 kg
	1200 kg	–	–	–	0.2 kg
	1500 kg	0.5 kg	0.2 / 0.5 kg	0.1 / 0.2 / 0.5 kg	–
PUA57..FH	1200 kg	–	–	–	0.2 kg
	1500 kg	0.5 kg	0.2 / 0.5 kg	0.1 / 0.2 / 0.5 kg	–

* MR = MultiRange
MI = MultIntervall

Notes

- If the configuration is changed, the new measuring data sign has to be adhered to the ID card.
- Further variants can be configured at weighing platforms with an IDNet interface in Service mode, see the Service Manual A/D Converter Point 22004255.
- In compulsory-certification operation the PUA579(x) mobile weighing platform may only be operated with a resolution of 1 x 3000 e SR or 2 x 3000 e MR.

11 Dimensions

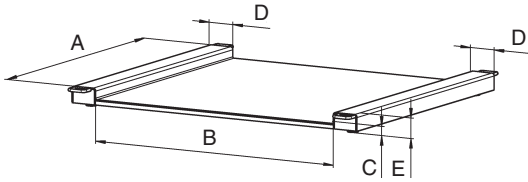

Dimensions in mm

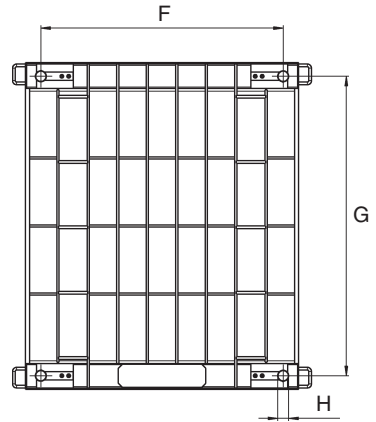

	PUA57..CS	PUA57..E	PUA57..FL	PUA57..FM	PUA57..FH
A	850	1500	750 ... 1250	1000 ... 1500	1500
B	850	1250	400 ... 1000	1000 ... 1250	1250 ... 1500
C	35	35	35	35	45
D	100	100	100	100	100
PUA574-E	72	115	72	115	115
PUA579-E	72	72	72	72	72
F	736	1386	A-114	A-114	1386
G	950	1350	B+100	B+100	B+100
H	40	40	40	40	40

PUA579(x)mobile

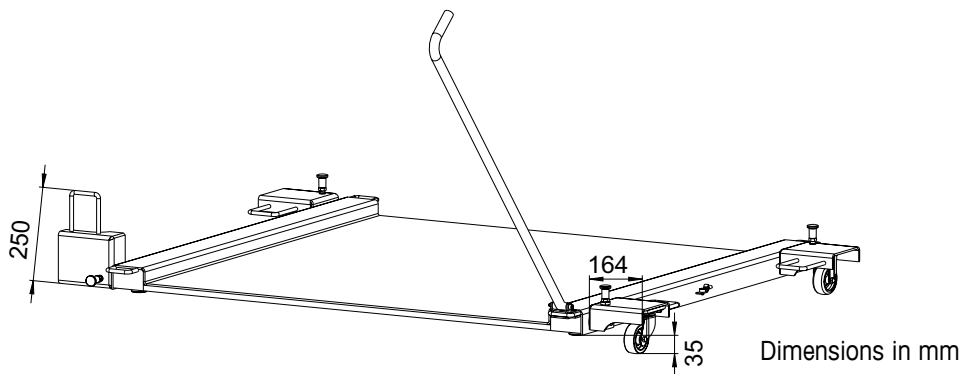

12 Cleaning the weighing platform

Maintenance of the weighing platform is limited to regular cleaning. The procedure depends on the type of surface and on the ambient conditions prevalent at the installation site.

12.1 Cleaning agents

- Only use disinfectants and cleaning agents in accordance with the manufacturer's instructions!
- Do not use highly acidic, highly alkaline or high-chlorine-content cleaning agents. Avoid substances with a high or low pH value, since the danger of corrosion is otherwise higher.

12.2 Cleaning in a dry environment

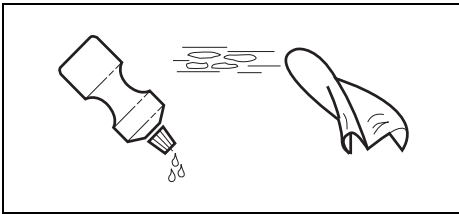

- Wiping with a damp cloth
- Common household cleaning agents

12.3 Cleaning the exterior (weighing platform standing on the floor)

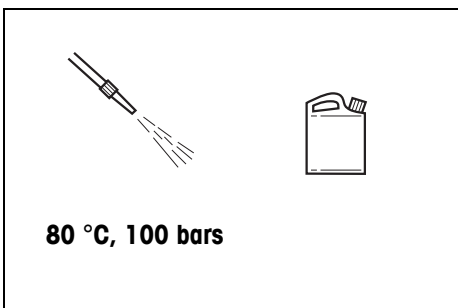

- Remove corrosive substances, dirt and deposits regularly from the surface.
- Check the gap between the weighing platform and the access ramp/wheel set and remove any soiling.
- Water temperature up to 80 °C
- High pressure up to 100 bars
- For subsequent treatment see Section 12.5

12.4 Cleaning from below (in conjunction with a lifting system)

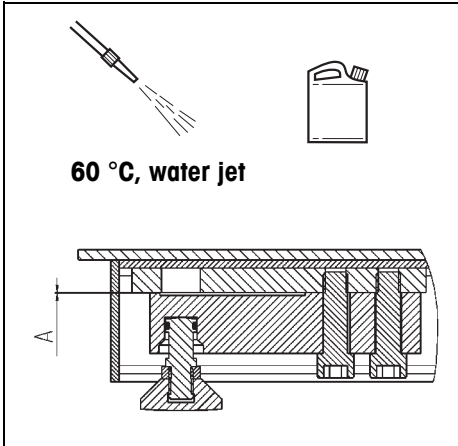

- Fold up the weighing platform with a lifting system.
- Remove corrosive substances, dirt and deposits regularly from the surface.
- Water temperature up to 60 °C
- Water jet
- Use compressed air to clean dirt particles from Gap A between the overload protection of the measuring cell and the load frame of the weighing platform.

12.5 Subsequent treatment

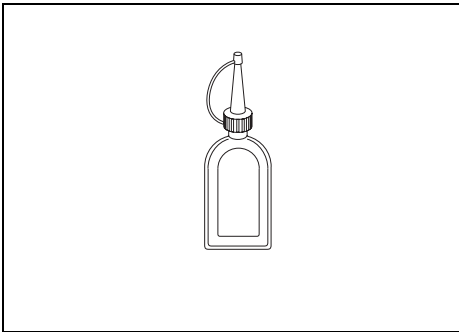

Carry out the following subsequent treatment to protect the weighing platform against corrosion:

- After the cleaning process rinse the weighing platform intensively with clear water.
- Remove cleaning agent completely.
- Oil the weighing platform regularly from above and below using the supplied universal oil (suitable for foodstuffs).

13 Standard accessories

Mechanical accessories

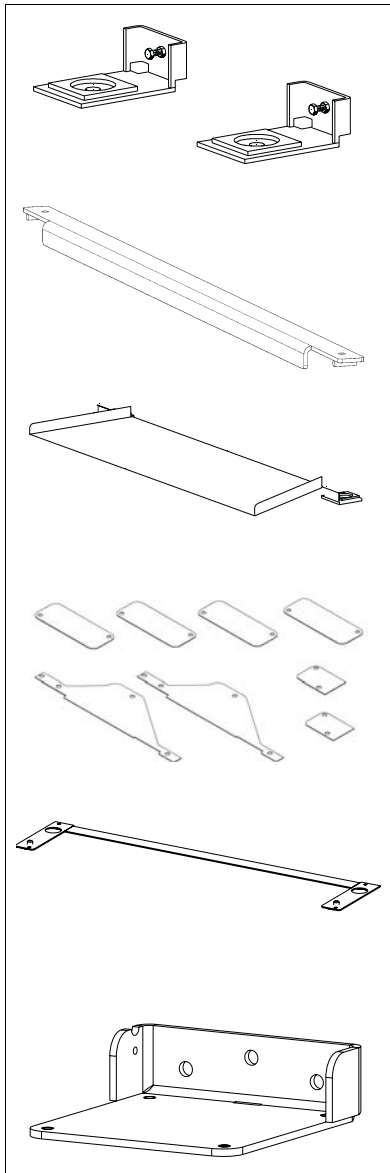

Foot plate set, with stop

for PUA574 (coated)	22 012 783
for PUA579(x) (stainless)	22 012 778

Passage stop

for PUA574 (coated)	22 014 206
for PUA579(x) (stainless)	22 014 208

Access ramps, coated

for PUA574-CS	22 012 784
for PUA574-E	22 012 785
for PUA574-FL/FM	22 012 786
for PUA574-FH	22 012 787

Sealing set

Rubber plates for sealing on the floor, for 2 x ramps, 1 x foot plate set or 1 x lifting device, incl. special dowels	22 006 354
--	------------

Rampfix for PUA579(x)mobile

Material: V2A/AISI304	
for PUA579(x)mobile CS	22 023 325
for PUA579(x)mobile E	22 023 326
for PUA579(x)mobile FL/FM	22 023 327
for PUA579(x)mobile FH	22 023 328

Adapter plate for PUA579(x)mobile

for fastening a standard floor stand	22 023 329
Material: V2A/AISI304	

Access ramps, stainless

	Basic model	Options	
Size	stainless	V4A/AISI316	ground
for PUA579-CS	22 012 779	00 599 929	00 599 933
for PUA579-E	22 012 780	00 599 930	
for PUA579-FL/FM	22 012 781	00 599 931	
for PUA579-FH	22 012 782	00 599 932	

Order example for access ramps, stainless

Ramp for PUA579-CS / V4A/AISI316 / ground:



 22 012 779 + 00 599 929 + 00 599 933

Installation frame

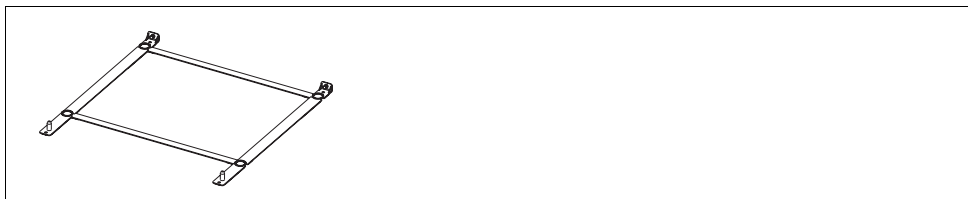

	Basic model, V4A/AISI316		Option
Size	1 ramp	2 ramps	ground
for PUA579-CS	22 017 751	22 017 759	00 599 934
for PUA579-E	22 017 752	22 017 760	
for PUA579-FL/FM/FH	22 017 753	22 017 761	

Lifting device

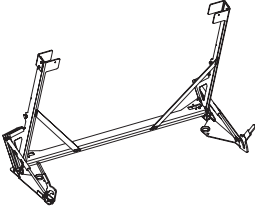

Lifting device	for PUA579 length x clearance in mm	Basic model	Options	
		V2A/AISI304	V4A/AISI316	ground
850	850 ... 1250 x 850	22 015 715		
1000	850 ... 1500 x 1000	22 015 718	00 599 936	00 599 935
1250	1100 ... 1500 x 1250	22 015 719		

Accessories for analog version

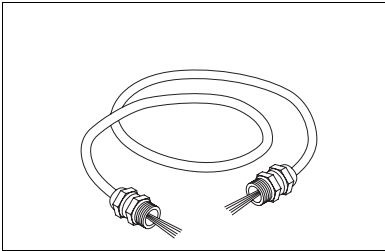

Order No.

Connection cable analog

00 204 555

10 m long, with integral connectors
at both cable ends
for remote control of the terminal
with integrated A/D converter

Accessories for IDNet version

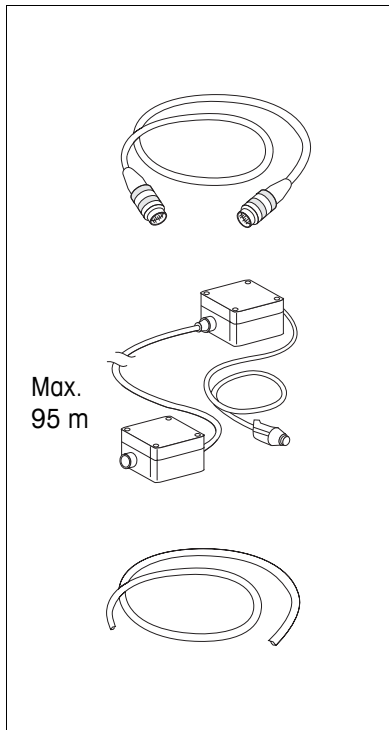

Order No.

Connecting extension cable

00 504 134

10 m long, pluggable on both ends
for remote control of the IDNet
terminal

Connecting set for IDNet terminals

00 504 133

for progressive extension of the
connecting cable to 100 m
consisting of two terminal boxes
Box at terminal end with connecting
cable 2.5 m long

Special cable from the roll

00 504 177

100 m, in connection with the
connecting set for progressive
extension of the connecting cable
for IDNet terminals

14 Disposal



In accordance with the requirements of the European Directive 2002/96 EC about Waste Electrical and Electronic Equipment (WEEE) this equipment may not be disposed of in the household refuse.

This applies correspondingly for countries outside the EC in accordance with the applicable national regulations.

→ Please dispose of this product in accordance with the local regulations in a separate collection for electrical and electronic equipment.

Should you have any questions, please contact the responsible authorities or the dealer from whom you purchased this equipment.

If this equipment is passed on (for example for private or commercial/ industrial further use), this specification has to be passed on correspondingly as well.

Many thanks for your contribution to protecting the environment.

METTLER TOLEDO Service

METTLER TOLEDO products stand for highest quality and precision. Careful handling in accordance with these operating instructions as well as regular maintenance and inspection by our professional customer service ensure the long and reliable function and maintenance of value of your measuring instruments. Our experienced service team will be pleased to inform you about corresponding service agreements or calibration services.

Please register your new product under www.mt.com/productregistration, so that we can inform you about improvements, updates and further important information about your METTLER TOLEDO product.



22014202D

Subject to technical changes © Mettler-Toledo (Albstadt) GmbH 10/11 Printed in Germany 22014202D

Mettler-Toledo (Albstadt) GmbH

D-72458 Albstadt

Tel. ++49-7431-14 0, Fax ++49-7431-14 232

www.mt.com/support