

**550**  
**Total Organic Carbon**  
**Analyzer**

**Instruction Manual**

**METTLER TOLEDO**

A graphic element consisting of a series of parallel, slightly curved lines that form a triangular shape pointing towards the top right. The lines are more densely packed in the center and become sparser towards the edges.

## IMPORTANT SAFETY INFORMATION

Please read and observe the following:

**INSTALLATION:** This instrument must be installed by trained instrumentation personnel in accordance with relevant local codes and instructions in this manual. Observe all instrument specifications and ratings.

**SHOCK HAZARD:** Make sure power to all wires is turned off before proceeding with installation or service of this instrument. High voltage may be present on the input power and relay wires.

**RELAY CONTROL ACTION:** Relays will always de-energize on loss of power, equivalent to normal state, regardless of relay state setting for powered operation. Configure any control system using these relays with fail-safe logic accordingly.

**PROCESS UPSETS:** Because process safety conditions may depend on consistent operation of this instrument, take appropriate action to maintain conditions during sensor cleaning, replacement or sensor or instrument calibration.

This manual includes safety information with the following designations and formats:

**WARNING: POTENTIAL FOR PERSONAL INJURY.**

**CAUTION: possible instrument damage or malfunction.**

**NOTE:** important operating information

## SERVICE AND REPAIR INFORMATION

This manual provides instruction to properly setup and operate the 550 model TOC Analyzers. Tampering with, modifying, or dis-assembly of any internal components of this analyzer beyond that, which is explicitly spelled out in this manual, is prohibited and will render the manufacturers warranty null and void.

# TABLE OF CONTENTS

<b>CHAPTER 1: GETTING STARTED</b> .....	<b>1</b>
INTRODUCTION .....	1
PRINCIPLE OF OPERATION .....	2
<b>CHAPTER 2: INSTALLATION / SET-UP</b> .....	<b>4</b>
LOCATION .....	4
ELECTRICAL CONNECTIONS .....	4
SAMPLE TUBING CONNECTIONS .....	4
ANALOG OUTPUT .....	5
ALARMS .....	5
USER INTERFACE/PRINTER .....	5
START-UP .....	6
<b>CHAPTER 3: CONFIGURATION</b> .....	<b>8</b>
USER SETUP AND CONFIGURATION MENUS .....	9
CALENDAR .....	10
SYSTEM NAME .....	11
OUTPUT SETUP .....	11
ALARM SETUP, CODES, and SETPOINTS .....	11
ALARM-X(1 OR 2) MODE CONFIGURATION .....	12
PRINT SET-UP .....	12
ANALOG (4-20 mA) OUTPUT .....	13
AUTO START .....	13
MEASUREMENT DISPLAY .....	14
AUTOMATIC ZERO CALIBRATION CONTROL .....	14
PRINTOUT OF CONFIGURATION DATABASE .....	15
<b>CHAPTER 4: DEMONSTRATION MODE</b> .....	<b>16</b>
<b>CHAPTER 5: OPERATION</b> .....	<b>17</b>
POWER ON .....	17
BEFORE MEASURING .....	17
MEASURING .....	17
TREND DATA CLEAR .....	18
PRINT TREND DATA .....	18
ALARM SETPOINT SCREEN .....	19
ALARM INDICATION .....	19
ERROR CODES .....	20
END MEASUREMENT .....	21
<b>CHAPTER 6: MAINTENANCE</b> .....	<b>22</b>
LAMP REPLACEMENT .....	22
<b>CHAPTER 7: CALIBRATION</b> .....	<b>24</b>
ANALOG OUTPUT CALIBRATION .....	24
AUTO ZERO CALIBRATION .....	25
BOARD CALIBRATION .....	25
MEASUREMENT VERIFICATION/CALIBRATION .....	29
<b>CHAPTER 8: ADVANCED CONFIGURATION</b> .....	<b>31</b>
ADVANCED START UP METHODS .....	31
VIEWING SENSORS .....	33

TOC CURVE .....	34
<b>APPENDIX A .....</b>	<b>36</b>
KEY/DISPLAY FUNCTIONS .....	36
SYSTEM CHECK SEQUENCE .....	37
550 OPERATION CHART - Measurement Mode .....	38
550 OPERATION CHART - Setup Mode.....	39
550 OPERATION CHART - Setup Mode (Maintenance menus) .....	40
550 OPERATION CHART - Maintenance Mode (Other Setup menus) .....	41
OPTIONAL PRINTER DIP SWITCH SETTINGS.....	42
<b>SPECIFICATIONS .....</b>	<b>43</b>
<b>ACCESSORIES AND REPLACEMENT PARTS .....</b>	<b>44</b>
<b>CE DECLARATION OF CONFORMITY .....</b>	<b>45</b>
<b>DECLARATION OF CSA COMPLIANCE.....</b>	<b>46</b>
APPLICABLE REQUIREMENTS.....	46
<b>WARRANTY .....</b>	<b>47</b>

# CHAPTER 1: GETTING STARTED

---

## INTRODUCTION

Total Organic Carbon measurement is recognized in many industries as an important, and some cases, required measurement parameter for process certification and performance verification. It is evident that a fast response, easy to operate and maintain, device has recognizable benefits for the user.

The Thornton 550 Total Organic Carbon Analyzer provides a faster and easier method of on line measurement. As its predecessor, the 502P, the 550 TOC analyzer units offers the widest dynamic water quality range that can be measured without cumbersome reagents or accessories. And it is the only known TOC Analyzer to measure on-line continuously.

The 550 TOC Analyzer is an online device that can be used in a permanent installation and also as a portable device. TOC measurement is capable throughout a range of 0.1 to 1000 ppb for the standard and high temperature models, 0.05 to 30 ppb for the SX model.

The Mettler-Toledo Thornton, Inc. factory provides in-house calibrations and testing services and also offers Field Service support (consult local factory sales representatives for details).

The **Specifications, Principal of Operation, Installation, Configuration, Operation, Maintenance, and Calibration** of this unique, high-quality analyzer follow. If you have any questions or comments about this manual, or the analyzer itself, please do not hesitate to contact us.

United States Patent (No. 5,518,608) issued.

## PRINCIPLE OF OPERATION

The Thornton 550 TOC Analyzer measures Total Organic Carbon in pure and ultrapure water based on differential conductivity. This difference in conductivity is used to determine the amount of organic carbon present.

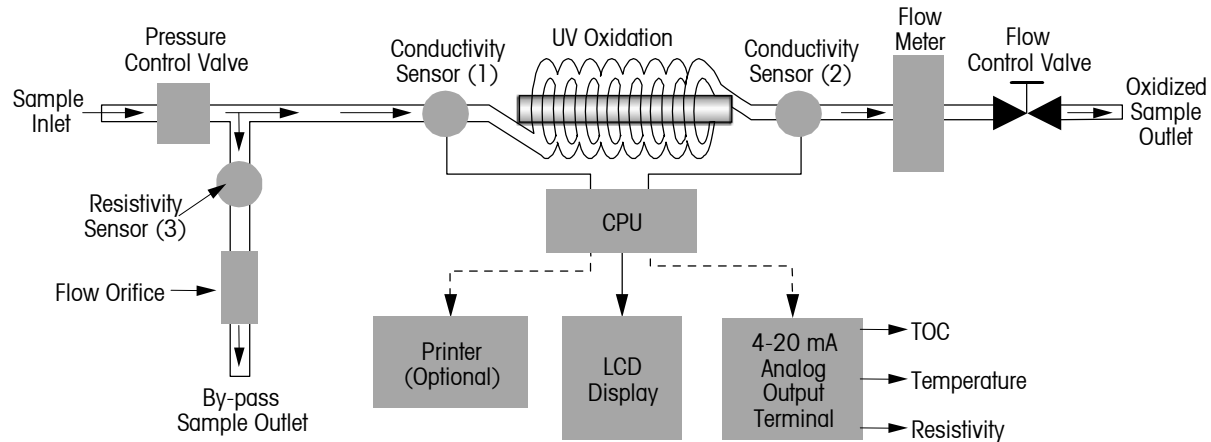

The sample water enters the analyzer and passes through a pressure regulator, which controls sample pressure to downstream components. Here the sample splits into two flow paths, where a portion of the flow is directed to the by-pass streamline, where resistivity/conductivity and temperature are measured via Sensor (3). These values are represented on the LCD display.

The other portion of the sample is directed through a second conductivity sensor, (1), measuring the sample conductivity prior to oxidation. Next, the sample enters the oxidation chamber. As the sample moves through the oxidation chamber, it is subjected to high intensity ultraviolet radiation at 185 nm, effectively oxidizing the sample to CO<sub>2</sub>.

After oxidation, the sample passes through a third conductivity sensor, (2), where the conductivity and temperature are measured again to determine the level of Total Organic Carbon (TOC).

The microprocessor of the Thornton 550 TOC Analyzer uses the measured values of initial (1) and final (2) conductivity and temperature to determine the change in compensated conductivity, which is related to the concentration of organic impurity in the incoming water stream.

The measurement and sample flow are continuous; therefore, measurement update time is minimized, providing rapid response to any system disturbances.

The oxidized sample stream passes through a flow meter, which has a fine flow-control adjustment, and then through the OXIDIZED SAMPLE OUTLET port. This effluent may be sent to waste or recycled. The operating flow rate is typically 20 ml/min, resulting in residence time in the oxidation chamber of less than one minute. The conductivity

measurements are continuous; therefore, response time is directly related to the residence time of the sample in the oxidation chamber.

Values of TOC, resistivity (or alternatively conductivity or uncompensated conductivity), and temperature are displayed on the LCD screen of the instrument. These values can also be printed or sent to a computer through RS-232 serial interface ports on the back panel of the instrument at a user-selectable time interval. The last 255 sets of values are stored in memory at the same time interval for viewing on the screen, or a designated number of these data lines can be printed on a demand basis. Other outputs include a continuous 4-20mA self-powered analog output signal and two configurable potential-free alarm contacts. Refer to the specifications in the back of this manual for details regarding these outputs

## CHAPTER 2: INSTALLATION / SET-UP

---

### LOCATION

The Thornton 550 TOC Analyzer is to be installed in a dry environment with a relative humidity <80% (non-condensing) and with ambient temperature between 5 and 40°C (41 to 104°F), on a flat, horizontal surface. The sample inlet line should be fitted with an isolation valve. The OXIDIZED SAMPLE OUTLET and BYPASS SAMPLE OUTLET tubes are led to waste (or a water reclaim system) at atmospheric pressure without any obstructions in the tubing.

### ELECTRICAL CONNECTIONS

A power outlet must be available within 3 ft. (1 m) when using the 3-pronged power cord supplied with the analyzer. An adapter for the power cord may be necessary for outlets of different configurations, depending on the country in which the unit is installed. The unit requires a power source between 100 and 240 VAC at either 50 or 60 Hz. Maximum power consumption is 50 W (with optional printer installed).

### SAMPLE TUBING CONNECTIONS



Three pieces of 2.5 m (8 ft) tubing are supplied with the unit. Two pieces are relatively clear and the third (PFA or similar Teflon<sup>®</sup> material) is opaque. The Teflon<sup>®</sup> tubing is used for connection from the sample water line to the SAMPLE INLET port on the back panel of the Analyzer. Hardware is to be assembled on the tubing as shown below for connection of the tubing to its port.

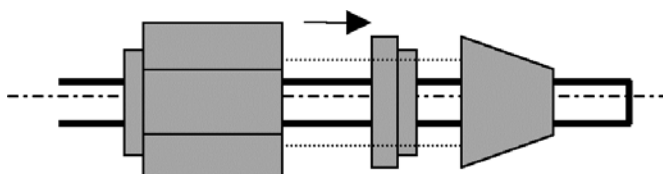

The tubing can be shortened to your application. Shorter tubing provides faster response time. Sample water pressure must be a least 0,5 bar (7.0 psi) but not greater than 7 bar (100 psi). A pressure regulator, located inside the Analyzer, protects the spiral quartz tube from damage by excessive inlet pressure.

The pieces of clear tubing are to be connected from the BYPASS OUT and from the OXIDIZED OUT ports to the user's drain at atmospheric pressure, without bends or kinks in the lines. Likewise, these two pieces of tubing can be shortened, although this will have no effect on performance.

## ANALOG OUTPUT

The two terminal connections on the left-hand side of the terminal strip on the back panel can be used for a self-powered 4-20 mA output. This output can be configured for remote use of TOC (most common), resistivity, or temperature signal. The maximum load resistance is 500 ohm.

## ALARMS

Two sets of alarm connections, Normally Open, Normally Closed and common, are provided on the same terminal strip. Each alarm can be independently configured as either NO (Normally Open) or NC (Normally Closed).

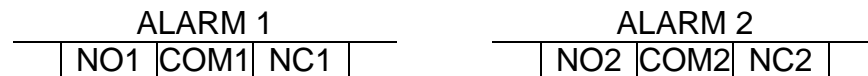

Each alarm output is driven by a SPDT relay rated at 0.4A @ 120 VAC or 2.0A @ 30 VDC. See **CHAPTER 3: CONFIGURATION** for more information.

## USER INTERFACE/PRINTER

Two RS232 connections are available and located on the rear-panel of the analyzer.

### PRINTER

The connection labeled 'PRINTER' is a 9-pin, male or female, sub-D connection for connecting an optional printer, with serial interface. The printer port can also be connected to a computer having a serial interface.

Communication specifications for this port: 9600 baud; 1 stop bit; no parity; 8-bit data. Software such as hyperterminal, a standard windows based software, may be utilized to collect data with a PC.

Mettler-Toledo Thornton, Inc. supplies a small format thermal printer as an optional accessory. A straight-through 9 pin, male or female, sub-D cable is provided with this printer. Configuration (Dip switch settings) for this optional printer can be found in the **APPENDIX**. An operation manual is also included with the printer. Power for this printer is supplied by the 550 TOC ANALYZER (6 VDC). The power connection is made at the rear of the analyzer.

## RS232C

The connection labeled "RS232C" is also a 9-pin sub-D connection for connecting a computer using a serial interface. This port, used in conjunction with a computer having serial interface capability, can be used as an alternate means to collect the operating data from the analyzer. The Computer must have the means to collect this serial data, which will be transmitted in the same format as it is transmitted to the optional printer. The following communication specifications apply.

Communication specifications for this port: 2400 baud; 1 stop bit; no parity; 8-bit data. Software such as HyperTerminal, a standard Windows® based software, may be utilized to collect data with a PC.

## START-UP

After all the tubing has been connected, sample water can flow through the unit. Open the user-furnished sample isolation valve. Observe the flow rate from the flow meter on the front panel of the Thornton 550 TOC Analyzer. Adjust the flow rate to the maximum setting by means of the flow adjustment knob, located at the top of the flow meter. If not already installed, connect the power cord to the socket located at the rear of the Thornton 550 TOC analyzer and insure the other end is connected to a suitable power source. Press the power button located at the rear of the analyzer to ON. This will enable the front display screen showing the Thornton name, model # and software version of the analyzer.

At this time, the analyzer should be rinsing with sample water to remove any impurity present on the sensors or in the system tubing and components. This will also help remove air bubbles, as any entrained air can cause errors in readings. Upon initial installation and start-up, it is recommended that the analyzer be rinsed for a minimum of 4 hours to 12 hours. The analyzer can be used immediately, but depending on water quality, time may be needed for readings to stabilize.

If the desired flow rate is not achievable, the internal pressure regulator may have to be adjusted. With the power to the Analyzer turned off and the power cord disconnected from the power source, remove the top cover. Depress each of the four buttons on opposite sides, just under the lip of the top cover, so that each of the 4 strips on top lifts open. The exposed, large Phillips®-head screws can now be loosened so that the top cover can be removed.

**Note:** There is a proper front and back to the cover. The bottom sides of the cover have male and female grooves, respectively. When replacing the cover, make sure the female groove on the cover lines up with the male mating surface on the housing on one side; the genders will be reversed on the other side.

The pressure regulator can be seen toward the back left of the analyzer. First, rotate the flow adjustment knob on the front of the analyzer counterclockwise, to the full open position. Then, on the internal pressure regulator, rotate the knob on the top of the regulator to adjust the pressure until the flow reads 100 ml/min.

After rinsing, use the flow adjustment knob to set the flow to 20 ml/min.

**CAUTION:** Even if no pressure adjustment is required (which is the usual case); the cover should be removed so that the analyzer can be checked for water leaks, as any leak could be a source of error in the readings and also could lead to damage or failure of the unit.

When all of these installation steps have been completed, replace the top cover, plug in the power cord, and press the power button, at the rear of the analyzer, to ON.

## CHAPTER 3: CONFIGURATION

---

The unit can be configured before or after installation as described in Chapter 2. When the unit is first powered, the following “TITLE” display will be seen.

THORNTON  
550 TOC Analyzer  
Ver 1. XX

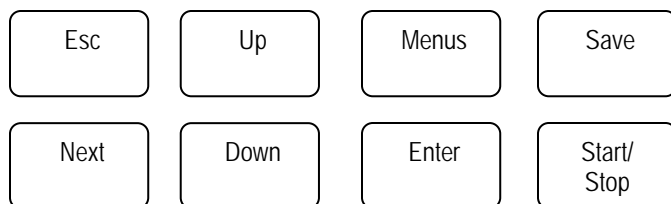

Symbol	Name	Major function
Menu	Menu key	Enter menu display
Save	Save key	Save changes
Start/ Stop	Start measurement Stop measurement	Start measuring TOC Stop measuring TOC
Up	Up key	Increase number / move the cursor or check mark ( * )
Down	Down key	Decrease number / move the cursor or check mark ( * )
Enter	Enter key	Enter or exit from a menu line
Esc	Escape key	Escape from the current menu level to the previous menu level
Next	Next key	Scroll the menu displays / move cursor

The 550 is available in three different models, the standard unit, known simply as the 550 will display the title as shown above. The High Temperature version will show the model number 550-HT and the enhanced resolution version will display the model number 550-SX. The current software version installed is also displayed below the model number.

This title screen will also display two other status indicators, when programmed to do so. In the bottom right-hand corner the word “Demo” will flash, indicating that the analyzer has been placed into demonstration mode. Also, it may flash “Auto Start ON,” when the analyzer has been programmed to do so.

As shown above the front panel of the 550 provides (8) eight keys for manipulation of the unit’s set-up, configuration, and maintenance menus. See KEYPAD/DISPLAY FUNCTIONS Table in the APPENDIX for a detailed description of the function of each key.

## USER SETUP AND CONFIGURATION MENUS

When the unit is in Standby mode, the first level of menu displays can be accessed by pushing the MENUS key. This array of menus will be used to setup or change the configuration of the 550 TOC Analyzer for normal operation. The 550 software contains a lockout function that when enabled allows configuration changes only if a password is entered. The screens should appear as follows:

**NOTE:** If lockout is enabled (‘Lockout ON’), when pushing the MENUS key from the Title Screen, the next screen will ask for Password Input. The factory default for this password is ‘0000’, (all zeros). The password can be configured for a personalized four-digit password from the Maintenance Menus. Otherwise pushing the Menu key from the Title screen will display the main menus.

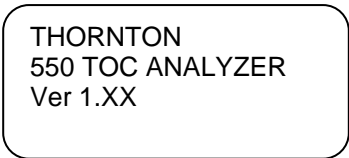

THORNTON  
550 TOC ANALYZER  
Ver 1.XX

Push MENUS key to enter the password screen as shown below:

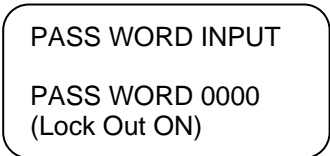

PASS WORD INPUT  
PASS WORD 0000  
(Lock Out ON)

Push ENTER Key to view the 1<sup>st</sup> page of the main menus as shown here:

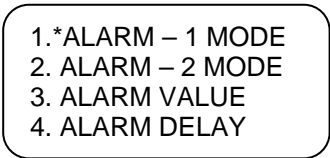

1.\*ALARM – 1 MODE  
2. ALARM – 2 MODE  
3. ALARM VALUE  
4. ALARM DELAY

Push the NEXT key to view the 2<sup>nd</sup> page of the main menus as shown here:

- 5. \*PRINT SETUP
- 6. ANALOG SETUP
- 7. ANALOG CALIB
- 8. UV TIME

Push the NEXT key again to see the 3<sup>rd</sup> main menus as shown here:

- 9. \*CALENDAR SETUP
- 10. SYSTEM CONFIG 1
- 11. SYSTEM CONFIG 2
- 12. MAINTENANCE

The above menus are the (12) twelve main menus used for set-up, configuration and maintenance of the 550 TOC Analyzer

## CALENDAR

First, set the Calendar by pushing the MENUS key. Once at the 1<sup>st</sup> menu screen, push the NEXT key until you reach the 3<sup>rd</sup> menu screen shown below:

- 9. \*CALENDAR SETUP
- 10. SYSTEM CONFIG 1
- 11. SYSTEM CONFIG 2
- 12. MAINTENANCE

If necessary move the \* to 9. CALENDAR SETUP using the DOWN key.  
Press ENTER.

Calendar Setup  
yy/mm/dd \*2003/07/20  
hh/mm/ss 11:20:35

This is a 24-hour clock. Press ENTER to access the yy/mm/dd fields. Use the NEXT key to move the cursor to the number to be changed. Use the UP/DOWN keys to change the number. After adjusting the date, press ENTER and move the \* with the DOWN key to the time. Adjust in the same manner. "SET OK" will flash. Press ESC to return to the previous menu screen.

**Note: The calendar is backed up by a battery on the printed circuit board.  
Confirm the time if the unit has not been powered for several weeks.**

Now that the general method of key/display is known, the remaining functions can be easily performed. Refer to the Appendix for a table of KEY/DISPLAY FUNCTIONS and the Operation Flow Charts.

## SYSTEM NAME

Go to “10. System Config 1” (on 3<sup>rd</sup> page of main menus) by moving the asterisk with the up/ and down keys, until it is on line 10.

```
9. CALENDAR SETUP
10. *SYSTEM CONFIG1
11. SYSTEM CONFIG 2
12. MAINTENANCE
```

Press ENTER.

```
SYSTEM CONFIG 1
Sys Name      *0000
Print-T unit   min.
Program Ver    x.xx
```

Press ENTER to highlight the first digit and using the UP, DOWN and NEXT keys, the Sys Name may be set at 0000 or it may be an abbreviated form of the serial number. For example, for S/N 960012, the Sys Name would be 9612. This is arbitrary, and it can be changed by the user.

## OUTPUT SETUP

This section provides instruction for setup of the 550 outputs. If you are using this Analyzer for measurement only, you may proceed to the AutoStart section of configuration. Otherwise, configure outputs as described in the sections below.

## ALARM SETUP, CODES, and SETPOINTS

The Thornton 550 has two independent relay alarms. Each can be configured for one of the three measurement parameters on the display. Choose the parameter and set point. The condition (NO or NC) for each relay is determined by the wiring terminals selected (see **INSTALLATION**). Configuring the alarms requires the following procedure. There is also a menu tree in **Appendix B**:

From the title screen press MENUS.

Move to 1. ALARM MODE-1 or 2. ALARM MODE-2.

Press ENTER to reach the following screen display for either alarm:

```
ALARM-1      MODE
ITEM =       *ppb
RELAY =      High On
HIST. =      00
```

## ALARM-X (1 OR 2) MODE CONFIGURATION

### ITEM

Select output parameter   ppb   = TOC  
                                  Mohm = Resistivity  
                                  °C    = Temperature of sample water  
                                  ERset = Error  
                                  None = no output

### RELAY

Definition of relay activation

Low Off = Relay off at lower than set point  
Low On = Relay on at lower than set point  
High Off = Relay off at higher than set point  
High On = Relay on at higher than set point

If Erset is selected in parameter, relay activation is automatically set to ON

### HIST.

This sets the Hysteresis associated with the alarm set point. A value from 0 to 99 can be entered.

HIST. = XX (0 to 99)

## PRINT SET-UP

If an optional printer is used, set up the printing of measurement data as follows:

In the MAIN Menus, 2<sup>nd</sup> screen Select: 5. Print Setup

```
Print Setup
Print Time =  01 Sec
History Wrt = OFF
Nr. Of Data = 0000
```

Use of History Wrt and Nr. Of Data are explained in **OPERATION**.

Print time is the interval between printing, in seconds, minutes or hours. This display shows an interval of 1. To change this value, move the cursor to the appropriate digit with the NEXT key; then UP or DOWN to change the value.

Ranges for print intervals are: 1-99 seconds, 1 - 99 minutes and 1-99 hours, all in increments of 1 (sec., min or hr.). This same time also determines Trend Data display (see **OPERATION**). To program the units of the Print Time and Trend Data, go to 10.System Configuration 1. Press Enter.

```
SYSTEM CONFIG 1
Sys Name      0000
Print-T unit  *sec
Program Ver   x.xx
```

Using the down key move the cursor to Print-T unit. Press enter. Using the up key change the unit to sec, min, or hour. Press enter. Press save. Select yes by using the

up key. Press enter. Note: Changing Print-T unit will reset the print time to 01. Press the esc key twice to return to the title screen.

## ANALOG (4-20 mA) OUTPUT

In the MAIN menus, 2<sup>nd</sup> screen, Select: 6. 4-20 mA SETUP

```
ANALOG SETUP
Output      = *ppb
4mA Lmt    = 000.0
20mA Lmt   = 100.0
```

The Output options are as follow:

ppb	TOC (ppb)
Mohm	Resistivity (Mohm-cm)
°C	Temperature (°C)
Hold	Holds current value (Used for 4-20 mA calibration)
Not Select	Analog signal configured, output not used
None	No configuration, output not used

In the above display, the 4-20 mA output is configured for TOC. The 4mA output represents 0.0 ppb TOC, and 20 mA represents 100.0 ppb TOC. These limit values are user selectable with values of 000.0 to 999.9.

## AUTO START

In the MAIN Menus, Refer to 11. SYSTEM CONFIG 2:

```
9. CALENDAR SETUP
10. SYSTEM CONFIG1
11. *SYSTEM CONFIG2
12. MAINTENANCE
```

Press ENTER.

```
SYSTEM CONFIG 2
Auto Start      *OFF
Print SYS Conf. OFF
History Clear   OFF
```

When AUTO START is set to OFF, the operator must push START to initiate the measuring process. When it is set to ON, the measurement process begins any time the unit goes from the unpowered to the powered state. (This could be the result of the operator switching the power ON, or from restoration of power after an outage.) It is recommended that this be left OFF for initial operation in a particular application. To change the status insure the asterisk is in front of the OFF on the AUTO START line, press the ENTER key, and use UP/DOWN keys to toggle OFF/ON. Press SAVE to write to memory.

## MEASUREMENT DISPLAY

The user has the option of displaying the measurement value of the incoming water sample as resistivity, conductivity, or (temperature) uncompensated conductivity. To change from the default value of resistivity:

Go to MEASURE PARA 2, choose 12: MAINTENANCE, Then move the asterisk to 11. Other Setup. After entering Other Setup, set Write to ON to edit Other Setup parameters.

```
MAINTENANCE 4/4
10.  A/D View
*11. Other Setup
```

Press Enter.

```
Other Setup
Write      ON
```

Press Enter.

Press Next 3 times to go to 4. MEASURE PARA 2 screen.

```
4. MEASURE PARA 2
RESERVE2      0000
RESERVE3      1000
Sensor Status 0000
```

In the RESERVE2 line, the codes for measurement display are set by the fourth digit as follows:

XXX0 Resistivity ( $M\Omega$ -cm)  
XXX1 Conductivity ( $\mu$ S/cm)  
XXX2 Uncompensated Conductivity ( $\mu$ S/cm)

The display will indicate  $M\Omega$ -cm or  $\mu$ S/cm according to the code selected.

## AUTOMATIC ZERO CALIBRATION CONTROL

Zero calibration is to account for the small differences in measurement between Sensor-1 (S1) and Sensor-2 (S2). A zero calibration is performed by the "System Check" routine each time the START button is pushed to start measuring. This is explained in **ADVANCED CONFIGURATION**. However, the system can be configured to automatically zero-calibrate at set time intervals by use of the first digit from the left in RESERVE2 of MEASURE PARA2, shown above.

<u>Reserve2</u>	<u>Period of Auto Zero</u>
<u>0</u> XXX	No Auto Zero
<u>1</u> XXX	20 hours
<u>2</u> XXX	40 hours
<u>3</u> XXX	60 hours
<u>4</u> XXX	80 hours
<u>5</u> XXX	100 hours
<u>6</u> XXX	200 hours
<u>7</u> XXX	1000 hours

After changing this parameter, press Save to write it to memory; then switch the power OFF, then ON. Note the following:

1. The second digit of RESERVE2 is used to configure the communication port. The third digit is used for special functions only, and is normally zero. Its function is explained in **ADVANCED CONFIGURATION**.
2. RESERVE3 is not used and is normally set to 1000.
3. Sensor Status is normally 0000. It is changed only in certain operating situations, as explained in **ADVANCED CONFIGURATION**.

**For any application outside the normal operating parameters, please consult Mettler- Toledo Thornton, Inc. technical support department.**

## PRINTOUT OF CONFIGURATION DATABASE

A printer attached to the printer port can be used to print out the configuration database. This is advisable for documentation and helpful for troubleshooting. To print out the configuration database:

1. STOP measuring by pressing the START/STOP button.
2. Push Menus and page down to 11. SYSTEM CONFIG 2 using the NEXT and DOWN keys.

```

9.  CALENDAR SETUP
10. SYSTEM CONFIG 1
11. *SYSTEM CONFIG 2
12. MAINTENANCE

```

3. Press ENTER key

```

SYSTEM CONFIG 2
Auto Start      OFF
Print SYS Conf. *OFF
History Clear   OFF

```

4. Select Print SYS Conf. using the DOWN key and pressing ENTER. Toggle ON, using UP/DOWN keys and press ENTER.

All configuration parameters in the database will now be printed through the printer port.

## CHAPTER 4: DEMONSTRATION MODE

---

The Thornton 550 can be run in the Demonstration Mode to illustrate and allow practice in changing some of the parameters prior to actual use of the instrument. While the measurement value cannot be changed, other parameters, such as alarm set points, can be altered.

To access the Demo Mode, go to 12. Maintenance, using the Menus, NEXT and DOWN keys.

```
9. CALENDAR SETUP
10. SYSTEM CONFIG 1
11. SYSTEM CONFIG 2
12. *MAINTENANCE
```

After entering the Password (FACTORY default is "0000") using the UP and ENTER keys, the first screen, maintenance 1/4 will display.

```
MAINTENANCE 1/4
*1. Demo Mode On/Off
2. Sensor View
3. EEPROM Setup
```

The default selection is \*1. Demo Mode On/Off. ENTER will display the Demo ON/OFF screen as follows:

```
Playing Demo
Demo Mark    Off
```

Use UP to toggle to ON. Go back to the title screen by pressing the ESC key 3 times. In the lower right corner of the display "DEMO!!" will appear. If it does not the unit is not in demonstration mode. Push the START key, and the System Check cycle will commence. After about 3 min, the display will indicate SYSTEM CHECK PASSED and that the UV is ON. **This is for simulation only: the lamp is not actually powered.** Then, after about 2 min, the measurement screen appears.

Pushing the START/STOP key again returns the display to the TITLE screen.

Other functions can be examined and values, such as alarm set points, can be changed for purposes of demonstration. Refer to **CONFIGURATION** and also the Operation Flow Chart in the **APPENDIX**.

When finished, return to the Playing Demo screen to turn Demo OFF.

# CHAPTER 5: OPERATION

---

## POWER ON

Turn on the power at the switch on the rear panel of the Analyzer.

THORNTON  
550 TOC Analyzer  
Ver x.xx

TITLE Screen will appear as shown. High temperature units display 550-HT and SX units display 550-SX.

## BEFORE MEASURING

Before starting to measure, be sure the flow rate is adjusted to 20 ml/min (unless otherwise specified for your application.)

## MEASURING

Push START to initiate the System Check and Measure process.

SYSTEM CHECK  
Please Wait  
  
RESIST = 18.20 MΩ-cm

SYSTEM CHECK is blinking. The analyzer does an automatic zeroing to correct for any drift.



SYSTEMCHECK  
PASSED  
UV WARMING UP  
Please Wait  
RESIST = 18.20 MΩ-cm

SYSTEM CHECK PASSED now solid. UV Warming Up is blinking. UV Lamp is stabilizing during this period.



TOC = 200.32 ppb  
RES = 18.21 MΩ.cm  
TMP = 25.6 °C

Primary Measurement Display. Measurement is updated every 2 seconds.

**Trend data** can be viewed by pushing NEXT. ESC returns to the Measurement Display.

TIME	TOC	RES	TP
10:30	75.2	18.2	25
11:00	100.2	17.6	25
11:30	200.6	17.2	25

Time interval is determined by Print Setup. See **PRINT SETUP**.

From the above screen, the Measurement Trend Check Mode can be accessed with ENTER. The past record of measurement values can be accessed with UP/DOWN. Pressing ENTER again will show the three most current readings on the display.

TIME	TOC	RES	TP
10:30*	75.2	18.2	25
11:00*	100.2	17.6	25
11:30*	200.6	17.2	25

255 Lines of data are stored. The values are the instantaneous measurement at the time shown, not an average value.

ESC will return the display to the regular Measurement screen.

## TREND DATA CLEAR

If the unit has been moved and a new sample is being introduced, or it is otherwise desirable, the trend data can be erased. First, stop measurement with the START/STOP button. Press Menu key and then access TREND CLEAR in 11. System Config2 using the NEXT and DOWN keys.

9. CALENDAR SETUP
10. SYSTEM CONFIG 1
11. *SYSTEM CONFIG 2
12. MAINTENANCE

Press ENTER key.

SYSTEM CONFIG 2	
Auto Start	OFF
Print SYS Conf.	OFF
History Clear	*OFF

Select History Clear using the DOWN key and press ENTER. Toggle to ON using UP/DOWN keys, and press ENTER. The trend data will be cleared.

## PRINT TREND DATA

If a printer is connected to the printer port, the measurement trend data can be printed. Push Menu and move the asterisk to item 5. PRINT SETUP. Press ENTER to enter this menu.

5. *PRINT SETUP
6. ANALOG SETUP
7. ANALOG CALIB
8. UV TIME

Press Enter.

Print Setup	
Print Time =	10 sec
History Wrt =	OFF
Nr. of Data =	*0010

Select Nr. Of Data using the DOWN key and press ENTER. Move the cursor using the NEXT key and change to the desired number of most recent data lines you wish to print with the UP/DOWN keys. Press ENTER. Next, select History Write using the UP key, press ENTER and toggle ON using the UP/DOWN keys. Press ENTER. The number of data lines you selected will print out.

Push ESC twice to return to the Measurement Display.

## ALARM SETPOINT SCREEN

From the Measurement Screen, the Alarm Set point Screen can be accessed pressing NEXT twice (see **APPENDIX**).

ALM1 = 450.5 ppb  
ALM2 = 10.3 Mohm  
T.F = 1.234 R.F = 0.987  
UV TIME = 200 Hours

This display shows the set point values for Alarms 1 & 2. These are read-only and cannot be changed from this screen. *TF and RF are values from 6. TOC Calib in MAINTENANCE 2/4.* UV TIME is the total number of hours the present lamp has been used.

NEXT returns the display to the measurement screen.

## ALARM INDICATION

If an alarm condition is present, or occurs during measurement, an alarm message will appear in the measurement display. For example:

TOC = 200.32 ppb  
RES = 18.21 MΩ  
TMP = 25.6°C  
AL1.H UV



ERROR 16  
TMP1 OVER

This indicates that Alarm 1, a high alarm, has been activated. "UV" indicates that the recommended lamp life of 4,000 hours has been exceeded.

If a malfunction or abnormality occurs, an error screen will appear, and will alternate with the measurement screen.

According to the Error Code Table (see below), this indicates the temperature at Sensor-3 (Incoming Sample) is too high.

## ERROR CODES

Message	Fault	Cause
SYSTEM CHECK FAILED	Unable to measure TOC	Differential between sensors before UV oxidation is too great
ERROR 02	Unable to measure TOC	Conductivity of sample water is greater than 20 $\mu\text{S}/\text{cm}$
ERROR 03	Sensor 1 error	Sensor 1 cable not connected, or sensor fault
ERROR 08	Sensor 2 error	Sensor 2 cable not connected, or sensor fault
ERROR 13	Sensor 3 error	Sensor 3 cable not connected, or sensor fault
ERROR 18	UV lamp life finished	Replace UV lamp
ERROR 06 ERROR 11 ERROR 16	Sensor 1 temperature error Sensor 2 temperature error Sensor 3 temperature error	Temperature Sensor error, or temperature above allowable limit
ERROR 07 ERROR 12 ERROR 17	Sensor 1 temperature error Sensor 2 temperature error Sensor 3 temperature error	Temperature Sensor error, or temperature below allowable limit

Error 02, which prevents measurement, can be overridden using the “Sensor Status” function in MEASURE PARA 2. SEE CHAPTER 8 “ADVANCED CONFIGURATION”.

Press SETUP and select item 12. MAINTENANCE by pressing the NEXT and DOWN keys.

```

9.  CALENDER SETUP
10. SYSTEM CONFIG 1
11. SYSTEM CONFIG 2
12. *MAINTENANCE
    
```

Press ENTER, enter the Password, (Factory default is 0000), using the UP and ENTER keys, the first screen, MAINTENANCE 1/4, will display. Using the DOWN/UP keys, select Item 11. Other Setup.

```

MAINTENANCE 4/4
10. A/D View
*11. Other Setup
    
```

Press ENTER. Use UP/DOWN to toggle to ON. Press ENTER.

Using the NEXT key, select MEASURE PARA 2 screen (fourth screen in 'Other Setup' menu) and select Sensor Status using the DOWN key.

4. MEASURE PARA2	
RESERVE	0000
RESERVE	0000
Sensor Status	*0000

Change Sensor Status from 0XXX to 1XXX by pressing ENTER and UP keys. Refer to **ADVANCED CONFIGURATION** for more information.

## END MEASUREMENT

To terminate measurement at any time, press START/STOP, and the display will return to the TITLE screen.

# CHAPTER 6: MAINTENANCE

---

## LAMP REPLACEMENT

The only maintenance that is required on a regular basis is replacement of the UV lamp. When the lamp usage time has reached 4,000 hours, a UV lamp alarm appears on the display. At some point after 4,000 hours, the UV radiation will gradually degrade and eventually will affect the validity of the measurement.

**WARNING:** *Do not remove back cover with unit ON or Power to the unit ON. UV light is harmful to the eyes.*

1. Stop measuring by pushing the START/STOP key.
2. Switch power OFF.
3. Disconnect the power cord.
4. Allow unit to cool 10 minutes before changing the lamp.
5. Remove the round plate on the back panel of the analyzer.
6. Unplug the UV lamp lead.
7. Pull the lamp straight back, loosening it from its socket, and removing it from the unit.
8. The reverse procedure is used to install the new lamp. Grasp the new lamp at its outboard end, **being careful not to touch the glass**, and insert the lamp in the socket. If the glass portion of the lamp has been exposed to fingerprints or contaminants, clean the lamp with a high purity grade of methanol and a scratch-free cloth or towel.
9. Replace the round plate.
10. Connect the power cord.
11. Turn power ON.

The UV time must now be cleared in the software, so that the timer will start with 0 hours for the new lamp. The UV TIME CLR is accessed as follows:

- Press MENU.
- Scroll to 12. MAINTENANCE using the down key.
- Press Enter and change Password (Factory Default is 0000) using the UP key.
- Select MAINTENANCE 4/4 using UP/DOWN key.
- Scroll to 11. Other Setup using the DOWN key.
- Press ENTER and Toggle ON using UP/DOWN key. Press ENTER
- Press NEXT to access 5. UV TIME:

```
5.UV TIME
UV ON TIME = *0020
UV CHG TIME = 4000
UV TIME CLR = OFF
```

- Select UV TIME CLR using the DOWN key.

```
UV TIME
UV ON TIME = 0020
UV CHG TIME = 4000
UV TIME CLR = *OFF
```

- Press ENTER and toggle UV TIME CLR to ON using the UP/DOWN key and press ENTER. UV ON TIME will reset to 0000.
- UV TIME CLEAR will automatically return to OFF after clearing.
- Press ESC three times to return to TITLE screen.
- Press START to resume measurement.

# CHAPTER 7: CALIBRATION

---

Four aspects of Calibration are covered in this section.

- Analog Output Calibration. This procedure is used to calibrate the analog output loop.
- Auto Zero Calibration. This is a procedure, performed by the monitor itself, to obtain zero readings of the two TOC sensors and correct for any zero drift.
- Measurement Verification/Calibration. These are methods for verifying that the current calibration is valid, or to adjust factors for re-calibration.
- Sensor Board Calibration. This procedure calibrates the main PC board with a set of resistors, and it ensures that the electronics measure resistivity accurately.

## ANALOG OUTPUT CALIBRATION

The analog output loop can be calibrated as follows. From the title screen press the Menu key. Go to 6.ANALOG SETUP. Press Enter.

```
ANALOG SETUP
Output   = *hold
4mA Lmt  = 000.0
20mA Lmt = 500.0
```

Press ENTER and set the output to hold by using the UP key. Press ENTER

It is not necessary to push SAVE, as this is a temporary condition only and should not be written on the EEPROM.

Press ESC to exit back to the menu options and, with Down, select 7. ANALOG CALIB Press ENTER

```
ANALOG CALIB.
4 mA LOW = *1000
20mA HI  = 1000
HOLD     = 00
```

Since this is a digital device, only 2 points are necessary to calibrate the 4-20 mA output. At HOLD = 00, adjust the 4 mA LOW (otherwise meaningless) number until the output, as measured with a current meter reads 4 mA.

At HOLD = 100, do likewise for the 20 mA output value.

For calibrating a 4-20 mA analog receiver loop, such as one with a pen recorder, the additional intermediate HOLD values of 25 (8 mA), 50 (12 mA), and 75 (16 mA) can be employed. Adjust the receiver instrument indication to conform to these output values. After completion of the loop calibration, Press ESC and go to 6. ANALOG SETUP and change the Output code from hold.

## AUTO ZERO CALIBRATION

TOC measurement depends upon the difference in conductivity readings between Sensor 1 and Sensor 2. As with any electronic measurement device, the zero may drift slightly over a period of time. In order to maintain a high accuracy measurement, these two sensors should be auto-balanced.

This routine is actually initiated every time the START/STOP key is pressed to start the measurement. This is indicated on the display screen as “System Check.” Also, the instrument can be configured to initiate this routine at specified time intervals. This is achieved by setting the first digit from the left in RESERVE2 of MEASURE PARA2. See **APPENDIX A** for location of MEASURE PARA2 and **AUTOMATIC ZERO CALIBRATION CONTROL** for a table of Period of Auto Zero.

This Auto Zero Calibration is important for measurement in high-purity water. However, if the resistivity of the water is 10 M $\Omega$ -cm or lower, Auto Zero Calibration is not necessary, and the first digit of RESERVE2 should be left at 0.

If Auto Start has been set to ON, the Auto Zero Calibration (“System Check”) will commence anytime the unit is switched ON or returns to a powered condition after a power outage. Auto Start is found in SYSTEM CONFIG2. See **APPENDIX** and **CONFIGURATION**. For a further explanation of the Auto Zero Routine, refer to **ADVANCED CONFIGURATION**.

## BOARD CALIBRATION

This section describes a procedure to verify the functionality and accuracy of the electronics within the instrument. The Thornton 550 TOC Analyzer has two sensors for TOC measurement and one sensor for measurement of the incoming water sample. These sensors are connected to the motherboard of the 550.

Periodically, the motherboard should be calibrated for optimal performance of the sensors. This should be done just before a calibration verification. A convenient time may be when the UV lamp is changed after 4,000 hours.

The resistor set used for this calibration is designated Part No. 139-005 (139-007 for –SX models) and is available from Mettler-Toledo Thornton, Inc. The set consists of the following assemblies:

### **139-005 Resistor Set**

- 1 each Assembly A: 4 K $\Omega$  + 100 K $\Omega$
- 1 each Assembly B: 4 K $\Omega$  + 100 K $\Omega$
- 1 each Assembly C: Jumper
- 1 each Assembly D: 2 M $\Omega$  + 100 K $\Omega$
- 1 each Assembly E: 1000 pF, 2M $\Omega$  + 100 K $\Omega$

Stop the measurement and remove the top cover.

**CAUTION: POWER IS LIVE DURING THIS PROCEDURE.** Press Menus and select 12. MAINTENANCE using the NEXT and UP/DOWN keys. Press ENTER and change pass word (Factory default is 0000) using the UP key. Press ENTER and select 4. Board Calib in MAINTENANCE 2/4.

```

MAINTENANCE 2/4
*4. Board Calib.
5. Sensor Calib.
6. TOC Calib
    
```

Press ENTER ↓

```

BOARD CALIBRATION
S1S2  ØR   KR   TH
S3    ØR   MR C  TH
OPEN  Prs  Enter ESC
    
```

Press ESC to terminate this procedure and return to the Title Screen. To proceed, disconnect the Sensor 1 and Sensor 2 cables from the board (see Figure 1).

**Figure 1**

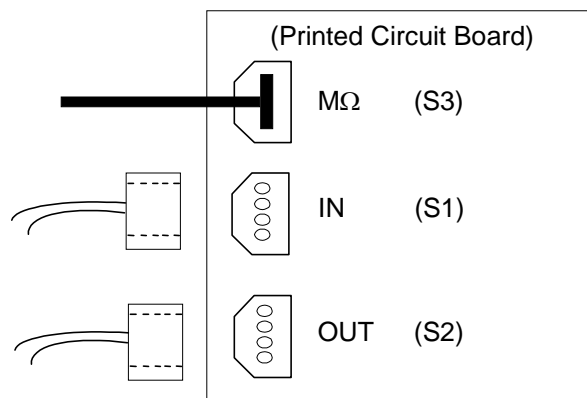

After disconnecting S1 and S2 from the board, push ENTER, resulting in these displays:

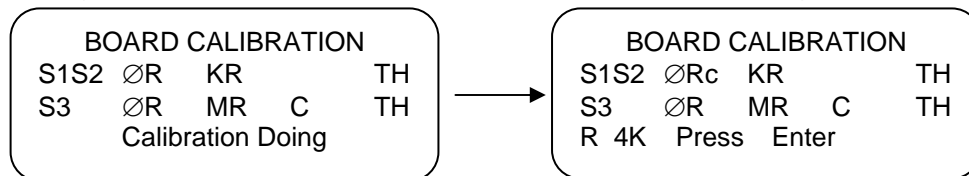

Plug one each of Assembly A and B into the connectors of S1 & S2 (see Figure 2).

**Figure 2**

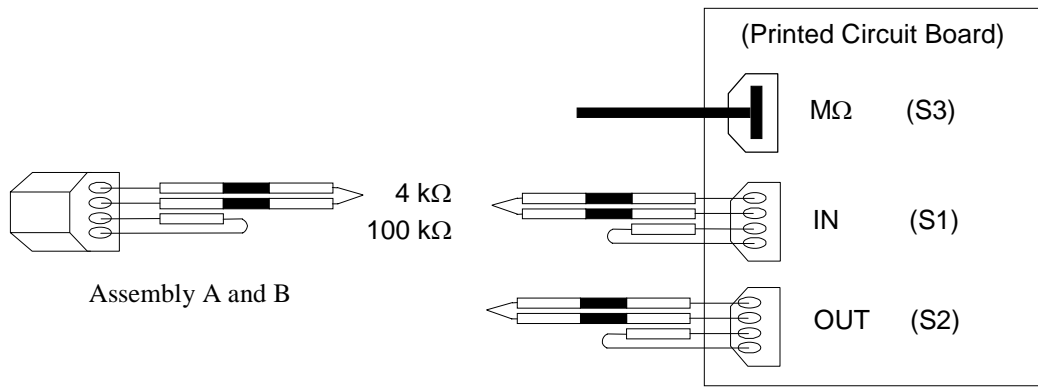

After inserting the resistor assemblies as shown above, press ENTER to result in these displays:

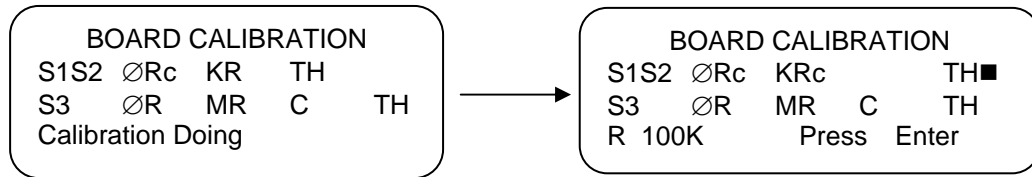

Press ENTER again:

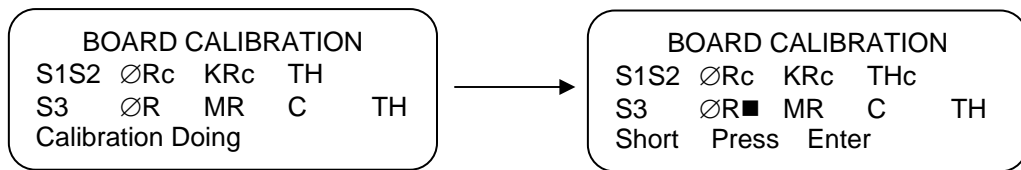

Remove the Resistor Assemblies from S1 and S2 as well as the sensor cable connector for S3. Insert Assembly C into the connector for S3 (see Figure 3).

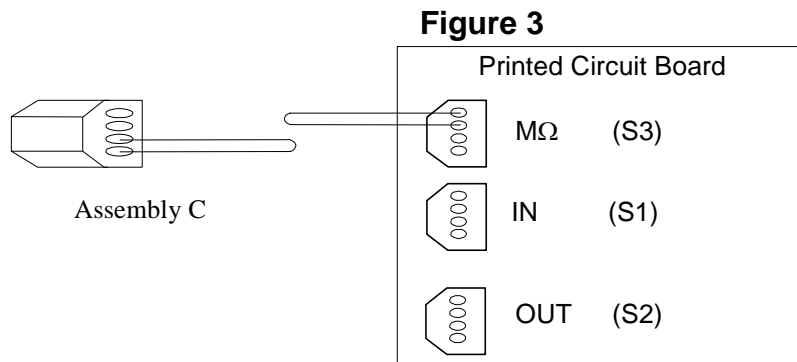

Press ENTER resulting in the following display:

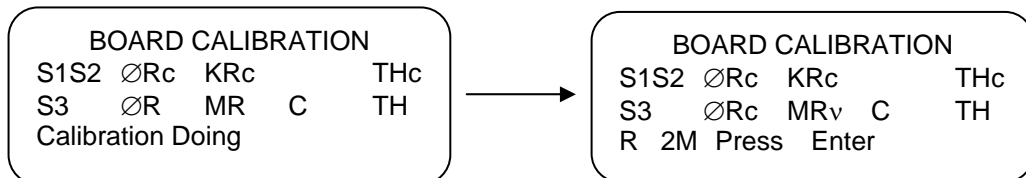

Remove Assembly C from the S3 connection and replace with Assembly D (see Figure 4):

**Figure 4**

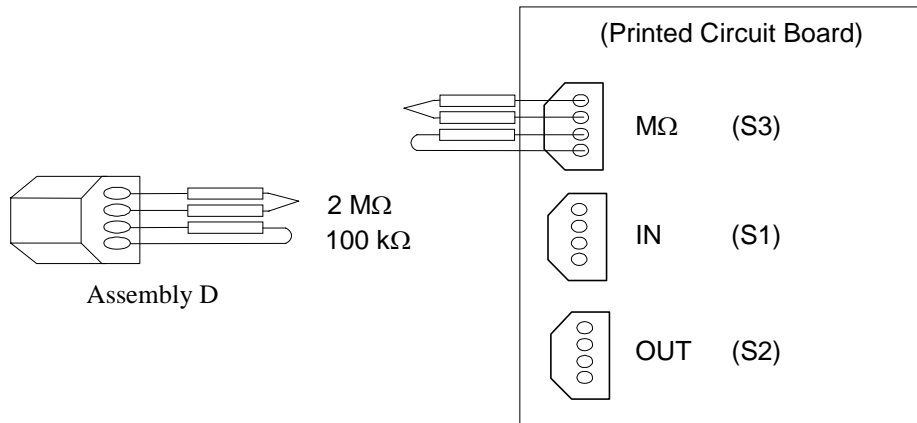

Press ENTER resulting in the following display:

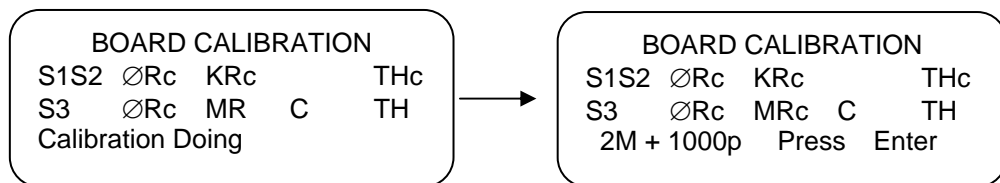

Replace Assembly D with Assembly E, which includes a capacitor (see Figure 5):

**Figure 5**

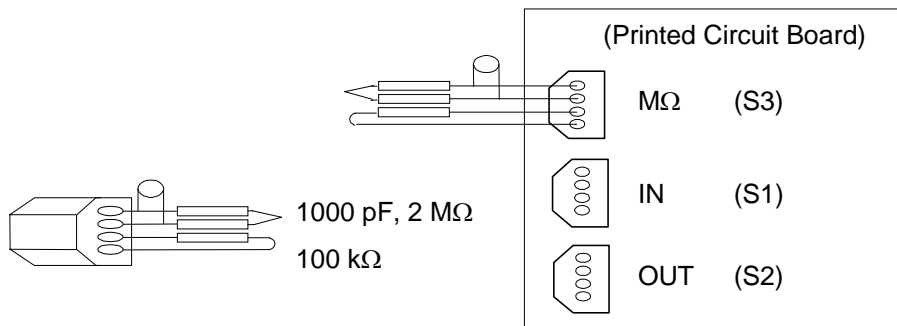

Press ENTER, for the following displays:

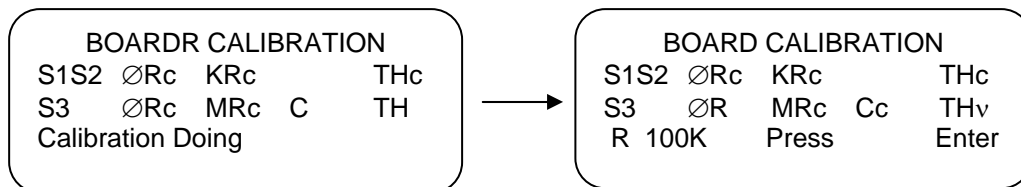

Press ENTER again for the following displays:

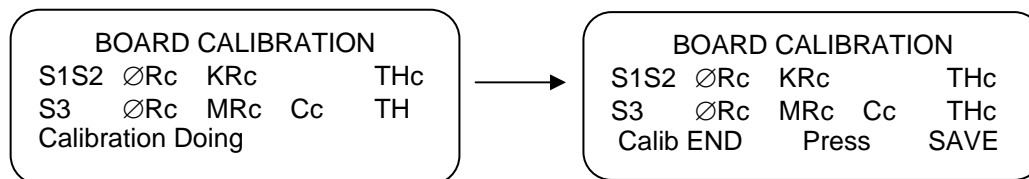

Press SAVE:Toggle to “YES”. Press ENTER  
Press ESC Twice.



Remove Assembly E.

Push the sensor connectors back into the plugs on the board. Replace top cover. Push START to resume measurement.

## MEASUREMENT VERIFICATION/CALIBRATION

Periodically, the performance of the Analyzer should be verified. It is recommended that factory trained and qualified personnel perform these services. Typically calibrations are performed at the Factory, however on-site service may also be provided in some cases (consult the Thornton Technical Services for details).

Typically the verification procedure is performed at the time of the UV lamp replacement. Refer to **MAINTENANCE** for the procedure for lamp replacement.

Before performing the TOC Verification/Calibration, it is advisable to do a board level calibration followed by a resistivity/temperature sensor verification/calibration. The board level calibration procedure uses resistor sets which are plugged into the sensor sockets on the main board. The procedure for board calibration follows in the next section. The required resistor set, Part No. 139-005, is available from Mettler-Toledo Thornton.

The resistivity/temperature sensor verification/calibration, which is performed after the board level calibration, can be best obtained using the values from a recently calibrated resistivity monitor and sensor, such as the Thornton 770MAX system. The measuring point of the 770MAX should be close to the connection point for the Thornton 550.

TOC verification/calibration can be performed a number of ways. One method of verification is to install a calibrated 550 TOC analyzer in parallel with the test unit. The results of TOC, Resistivity, and Temperature are compared over a period of time. If the results from the test unit compare favorably with the calibrated 550 TOC unit, within published operating tolerances, the test unit calibration is verified.

A second, more extensive TOC calibration, subjects the test unit to a known TOC level. A sample is prepared by adding some suitable reagent into low TOC water, to prepare a sample with known TOC level.

Run the calibration sample through the unit until stable readings are achieved. The instrument value can be adjusted in the following manner.

In the second screen of MAINTENANCE Mode, select 6. TOC Calib.

```
MAINTENANCE 2/4
4. Board Calib
5. Sensor Calib
*6. TOC Calib
```

Press ENTER

```
TOC Calibration
T 2.85 -> 2.85*
R 18.10 -> 18.10
T.F. = 1.000 R.F. = 1.000
```

Select T, and enter the known value of TOC. The processor will compare this to the instrument value and calculate a T.F. (TOC Factor), which is a multiplier, and adjust the instrument reading to conform to the known value.

# CHAPTER 8: ADVANCED CONFIGURATION

---

## ADVANCED START UP METHODS

The **CONFIGURATION** and **OPERATION** methods described previously should be adequate for pure and ultrapure waters (resistivity generally in the 10-18 MΩ-cm range) with relatively low levels of TOC. However, at higher levels of TOC, such as encountered in some Reverse Osmosis product water, recycle, and reclaim rinse water, an advanced configuration technique may be necessary for proper operation.

The indication that the standard procedure may need modification is if the “System Check” results in a display “SYSTEM CHECK FAILED” rather than advancing to the UV lamp stabilization stage.

The purpose of the System Check sequence is to zero out any differences between Sensor 1 and Sensor 2, before the UV oxidation process begins.

After the START key is pressed, the system waits for one minute and then examines the absolute difference between the S1 and S2 conductivity readings. If that absolute value is less than Calib No. 1 value (SEE TABLE ON NEXT PAGE), the display will read “System Check OK”. If the difference is not less than Calib No., the system will wait 20 seconds and read the measurement again. If necessary, this step will be repeated a third time.

If the System Check is still not OK, the system adopts Calib No. 2 (SEE TABLE ON NEXT PAGE) as the acceptable criterion. It will check up to five times with 20 seconds between attempts.

**Note:** *These two calibration values can be seen in the 2<sup>nd</sup> screen of the ‘Other Setup’ menus:*

Press Menus and select item 12. MAINTENANCE by pressing the NEXT and DOWN keys.

9. CALENDAR SETUP  
10. SYSTEM CONFIG 1  
11. SYSTEM CONFIG 2  
12. \*MAINTENANCE

Press ENTER, then enter the Password, (Factory default is 0000) using the UP and ENTER keys, the first screen, MAINTENANCE 1 / 4, will display. Use the NEXT button to reach the fourth Maintenance Screen 4/4. Using the DOWN/UP keys, select Item 11.Other Setup.

MAINTENANCE 4/4  
10. A/D View  
\*11. Other Setup

Press ENTER. The ‘Other Setup’ WRITE OFF/ON screen will appear on the display.

```

OTHER SETUP
WRITE      OFF
  
```

**NOTE:** Changing the WRITE OFF to ON will allow changes to be the factory settings within the 'OTHER SETUP' menu screens. This should only be turned to ON if changes are being made.

Using the NEXT key select INITIALIZE CHANGE screen.

```

2.INITIALIZE CHANGE
Calib. No. 1  *0010
Calib. No. 2   0050
  
```

The Table below shows the Calib. Numbers for each 550 model. Values are in units of  $\mu\text{S}/\text{cm}$ , these values are factory set and should not be altered as instrument performance may be affected.

	550	550-HT	550-SX
Calib. No.1	0010	0010	0006
Calib. No.2	0050	0550	0010

If the System Check fails after five tries, the processor reads the value of S3, which measures the resistivity of the incoming water sample. If the reading of S3 indicates the incoming water is less than  $10 \text{ M}\Omega\text{-cm}$  but greater than  $0.05 \text{ M}\Omega\text{-cm}$  ( $<20 \mu\text{S}/\text{cm}$ ), the processor will set the absolute value of the difference between S1 and S2 to zero. The System Check will be indicated as "PASSED". The UV lamp is automatically turned on and allowed to stabilize for approximately 2 minutes. The system then starts measuring and indicating TOC.

If the resistivity of the incoming water is  $<0.05 \text{ M}\Omega\text{-cm}$  (conductivity  $>20 \mu\text{S}/\text{cm}$ ), the display will indicate "System Check Failed". Error 2 is activated, and the unit will not measure TOC. This error indication can be disabled on the 4<sup>th</sup> screen of OTHER SETUP menus.

```

4.MEASURE PARA 2
RESERVE2      0000
RESERVE3      1000
Sensor Status *0000
  
```

- Select Sensor Status using the DOWN key. Press ENTER
- Using the UP key change Sensor Status from 0000 to 1000 to disable Error 2.
- Press Save to write this change to the EEPROM.
- Press ESC to return the display to the TITLE screen.
- Press START, and after the System Check sequence, the unit will measure and display TOC.
- If system check fails again, set Reserve2 to 0010 as described on next page.

If the resistivity of the incoming water is 10 MΩ-cm or above, the System Check not passing indicates there is a problem, and the screen will display “SYSTEM CHECK FAILED.” If this occurs, turn the unit off, then on again, and push the START button to once again initiate the System Check sequence. If the System Check again fails, the “System Check FAILED!!” can be overridden by changing the RESERVE2 in the MEASURE PARA 2 (4th screen in OTHER SETUP menus) as follows:

```
4.MEASURE PARA 2
RESERVE2    *0000
RESERVE3    1000
Sensor Status 0000
```

Select RESERVE2 using UP/DOWN key and press ENTER. Change from XX0X Normal System Check to XX1X Special System Check using the NEXT and UP keys. This will override “SYSTEM CHECK FAILED!!” and permit the sequence to advance to the next stage (turn on UV lamp.)

This means that the difference between the zero readings of S1 and S2 will not be eliminated and there may be some error in the measured TOC value. This error is usually insignificant in lower quality water (<10 MΩ-cm.)

## **VIEWING SENSORS**

To view the readings of the individual sensors, press Menu and select 12. MAINTENANCE using the NEXT and UP/DOWN keys.

```
9. CALENDER SETUP
10 SYSTEM CONFIG1
11. SYSTEM CONFIG2
12. *MAINTENANCE
```

Press ENTER, enter the Password, (Factory default is 0000), using the UP and ENTER keys, the first screen, MAINTENANCE 1/4, will display. Using the DOWN/UP keys, select Item 2. Sensor View and press ENTER.

```
MAINTENANCE 1/4
1. Demo Mode On/Off
*2. Sensor View
3. EEPROM Setup
```

```

Sensor View 1/4
S1  1.53652  23.75
S2  7.39979  23.35
S3  0.91     23.73

```

This first screen, Sensor View 1/4, shows temperature-compensated conductivity and temperature readings for S1 and S2 (resistivity for S3).

Press Next ↓

```

Sensor View 2/4
[S1]  1.49524
[S2]  5.75341
[S3]  0.93

```

Press Next. The second screen shows raw values (not temperature-compensated) of conductivity and resistivity.

Press Next ↓

```

Sensor View 3/4
TOC CURVE  01
TOC = 82.32
Delta = 5.86327

```

Press Next. The third screen indicates the TOC Curve presently in use, the TOC reading and the difference between S1 and S2.

Press Next ↓

```

Sensor View 4/4
Now D =    5.86327
Init D =    0.00008
PPB set =  *0000

```

“Now D” – “Init D” = Difference that is converted to TOC.  
PPB set : Not used

In the Sensor View area, it is possible to observe measurements in both the non-oxidizing mode (UV Lamp Off) and in the oxidizing mode (UV Lamp ON). First, the unit must be placed in the non-measuring (Standby) mode by pushing the START/STOP button, which turns off the UV lamp and returns the display to the TITLE screen. Once in non-measuring (Standby) mode, return to the Sensor View area in SETUP, as described above.

After sufficient time (about 2 minutes) has been allowed for the UV lamp to stabilize, the delta conductivity in the non-measuring mode (STAND BY) can be observed. This information would be requested in event of a problem where troubleshooting is required.

**CAUTION:** PRESSING THE MENUS KEY WHILE IN SENSOR VIEW, WILL TURN ON THE UV LAMP. THIS FUNCION EXISTS AS A MAINTENANCE TOOL AND IS INTENDED FOR USE BY AUTHORIZED THORNTON SERVICE PERSONNEL ONLY.

## TOC CURVE

In Sensor View screen 3 / 4, the display shows the TOC Curve designation used to determine the TOC value measured by the analyzer. The factory default for all three models, 550/550-HT/550-SX is TOC Curve1

This curve is designed to provide optimum performance for typical sample waters that meet the water quality and TOC range limits specified for these analyzers.

In certain circumstances, this Factory default may be changed. These are special cases where a sample water may contain known levels of specific organics, in which

case a different curve designation may be entered. This alteration will require factory support and should only be performed by factory trained and certified personnel.

# APPENDIX A

## KEY/DISPLAY FUNCTIONS

MODE KEY	MAJOR FUNCTION	FUNCTION WHEN UNIT IS MEASURING TOC	FUNCTION WHEN UNIT IS IN STANDBY	FUNCTION WITHIN ITEM 12. MAINTENANCE MENUS
START/ STOP	Start or Stop Measuring TOC	Stop Measuring TOC	Start Measuring TOC	
MENUS	Push to enter setup & configuration Menus	Push to enter setup & configuration Menus	Push to enter setup & configuration Menus	- Turns UV lamp on/off in sensor view  - Shows sensor view from sensor calib. screen
NEXT	Scrolls the menu displays or moves the Underline to the next location	Press Once, Displays the history, Press twice, displays alarm set points of a parameter. Total UV light time, TF, and RF		Moves the menu display down/ move cursor
SAVE	Saves changes made within menu screens	Saves changes made within menu screens		Saves changes made within menu screens
ENTER	Allows access to or exit from the menu lines and/or selected items.			Allows access to or exit from the menu lines and/or selected items.
UP	1. Selects an item (denoted by an *) 2. Increase a number	To read data in Data History		Moves the (*) within the menus or Increases a number
DOWN	1. Selects an item (denoted by an *) 2. Decrease a number	To read data in Data History		Moves the (*) within the menus or Decreases a number
ESC	Backs out of current menu screen	Escapes back to Measurement Mode		Backs out of current menu screen

# SYSTEM CHECK SEQUENCE

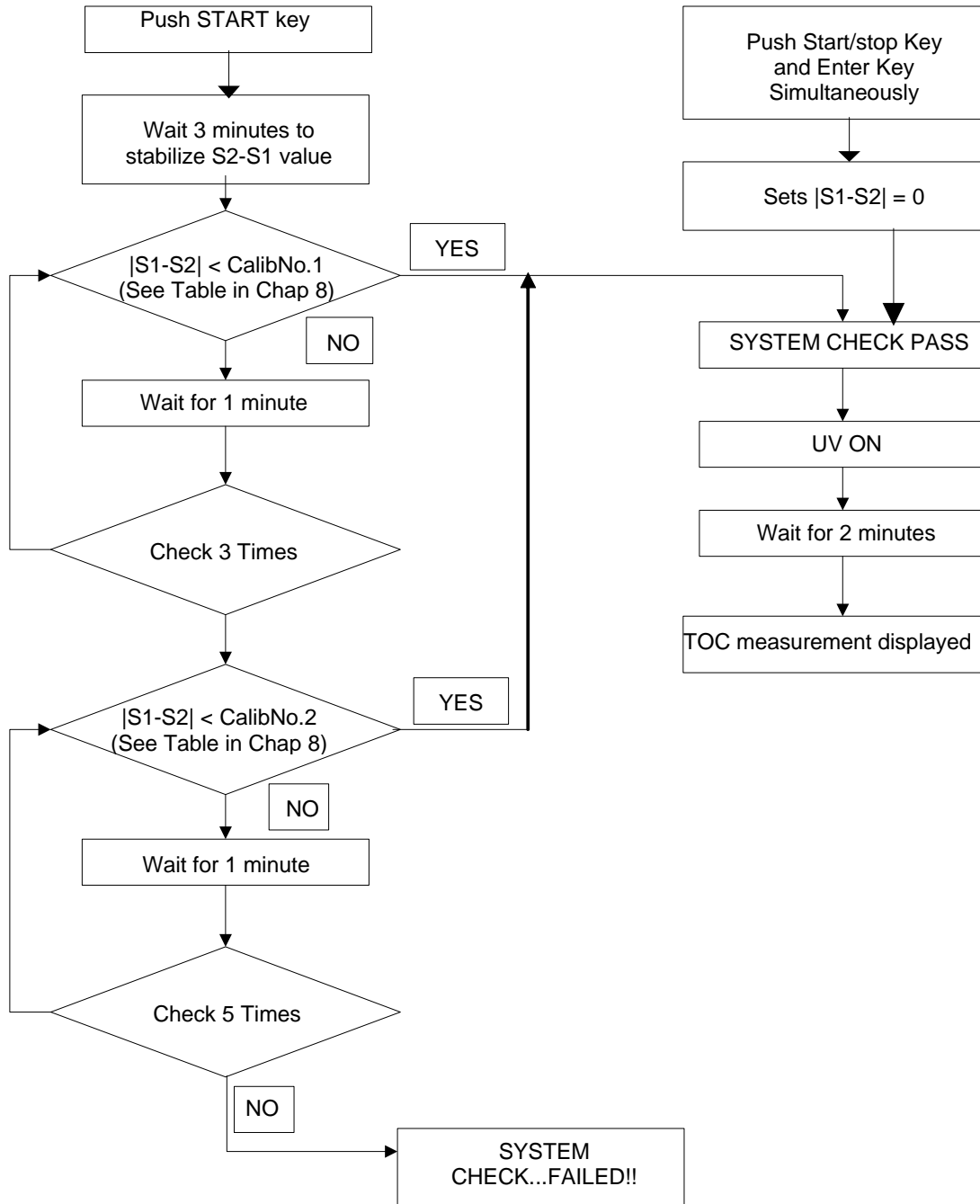

# 550 OPERATION CHART - Measurement Mode

## MEASUREMENT MODE

Flowchart shows Start-up (System Check) sequence and menu screens available during Measurement Mode

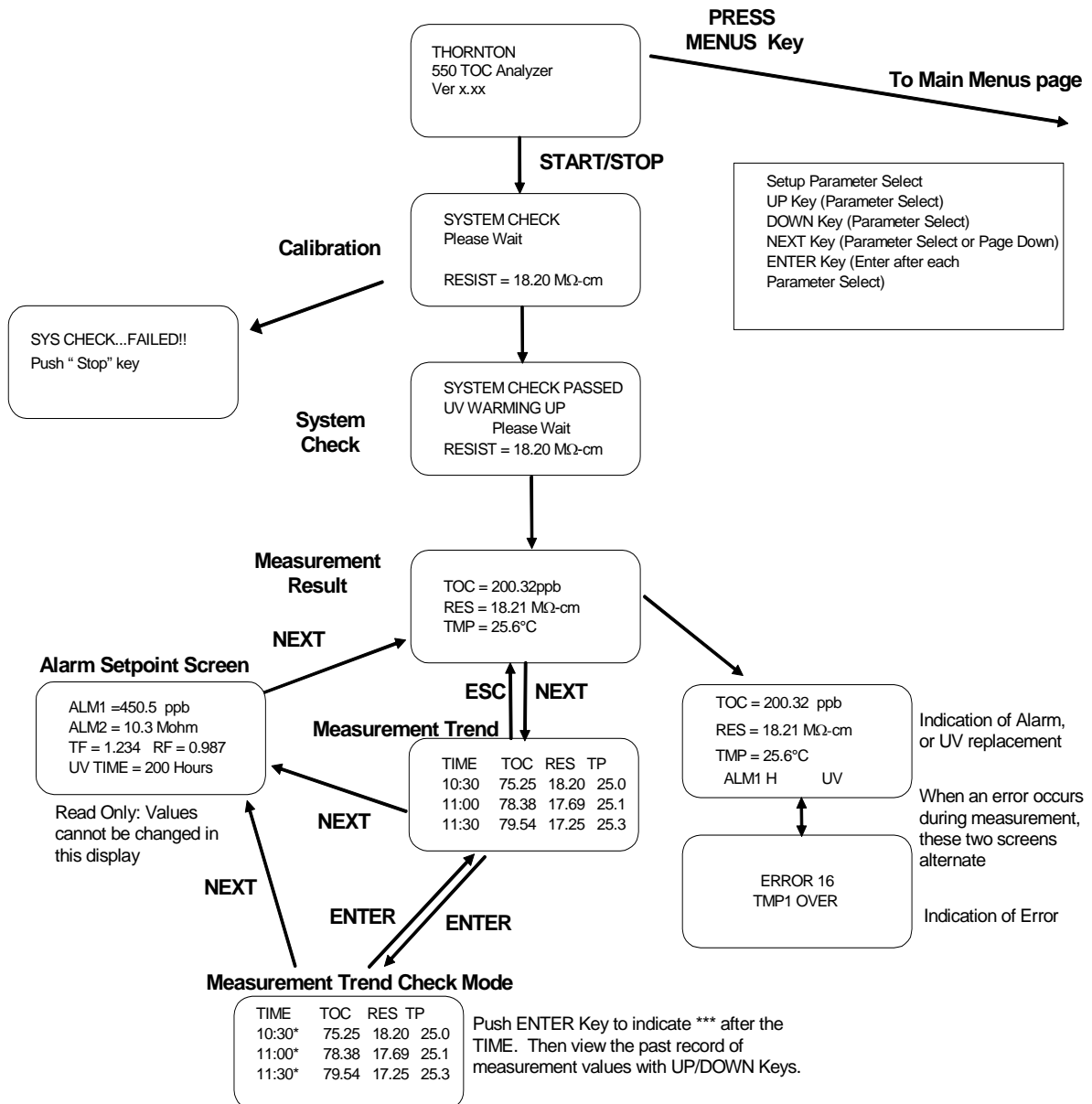

# 550 OPERATION CHART - Setup Mode

← Back to Measurement Mode or Title Screen (press ESC key once)

## SETUP MODE

Up Key.....Numerical Change  
 DOWN Key.....Numerical Change  
 NEXT Key.....Move the Cursor  
 ENTER Key.....Confirm the Set  
 Numerical Value

From Measurement Mode or Title Screen

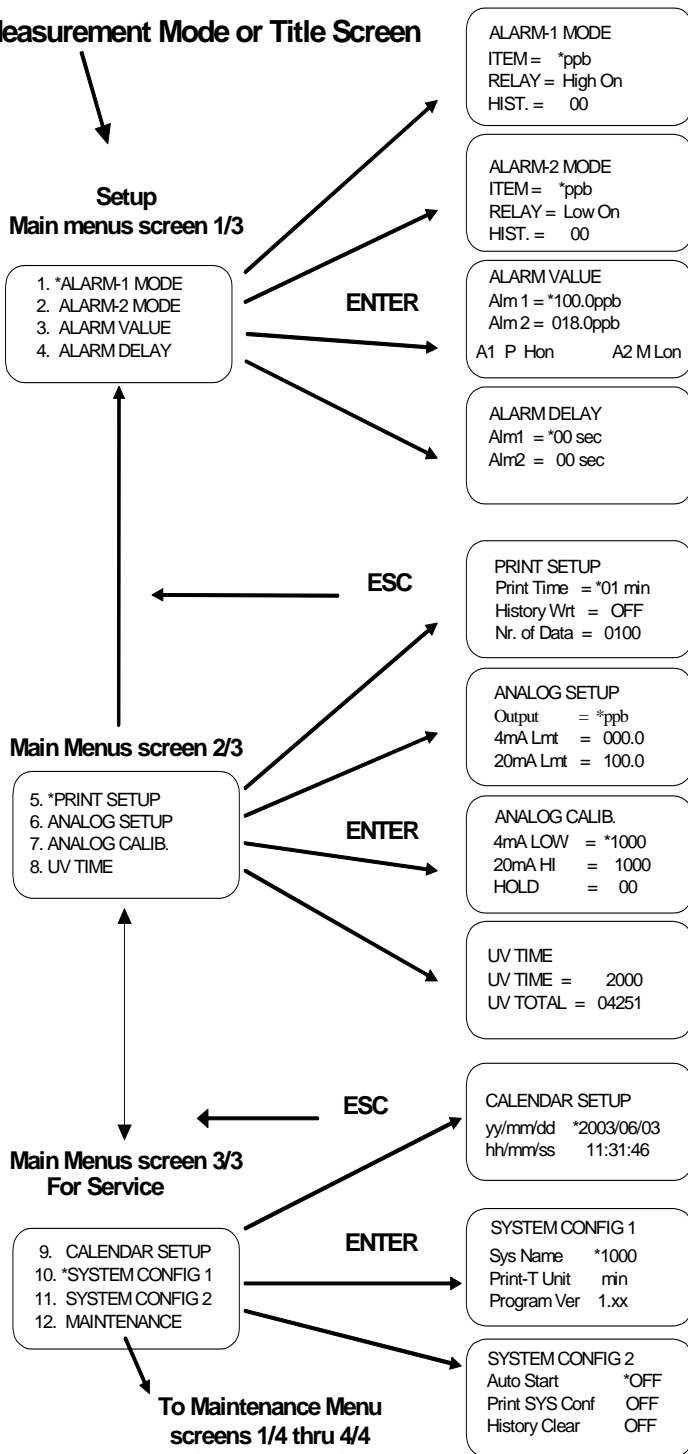

### Alarm 1 Setup

Item = Chooses parameter to alarm on.  
 Relay = Activation state when setpoint is reached.  
 HIST. = Histeresis

### Alarm 2 Setup

Item = Chooses parameter to alarm on.  
 Relay = Activation state when setpoint is reached.  
 HIST. = Histeresis

### Alarm Value

Configures Setpoint values  
 Designates what alarm, parameter s and what mode the activated alarm is configured to.

### Alarm Delay

Number of seconds before alarm triggers relay activation

### Print Setup

Configures time interval for data pt collection  
 For writing data pts to printer  
 Determines the number of data pts for History  
 Write function

### Analog Setup

For assigning measurement parameter  
 And values of 4 and 20 mA signal  
 See Configuration.

### Analog Output Calibration

Fro 4-20mA Output calibration  
 SEE Chapter 2. Installation  
 For output and loop calibration

### UV Time

Time of operation of present UV lamp  
 Total operating time of Analyzer

### Calendar Setup

Set Date and Time.  
 See Configuration.

### System Configuration 1

System name. See Configuration.  
 Printer time interval in sec/min/hr  
 Current Software version loaded.

### System Configuration 2

If ON, meas. begins when power applied.  
 Toggle ON to print out configuration data.  
 Toggle ON to clear trend history.

# 550 OPERATION CHART - Setup Mode (Maintenance menus)

← Back to Measurement Mode or Title Screen (Press ESC key twice)

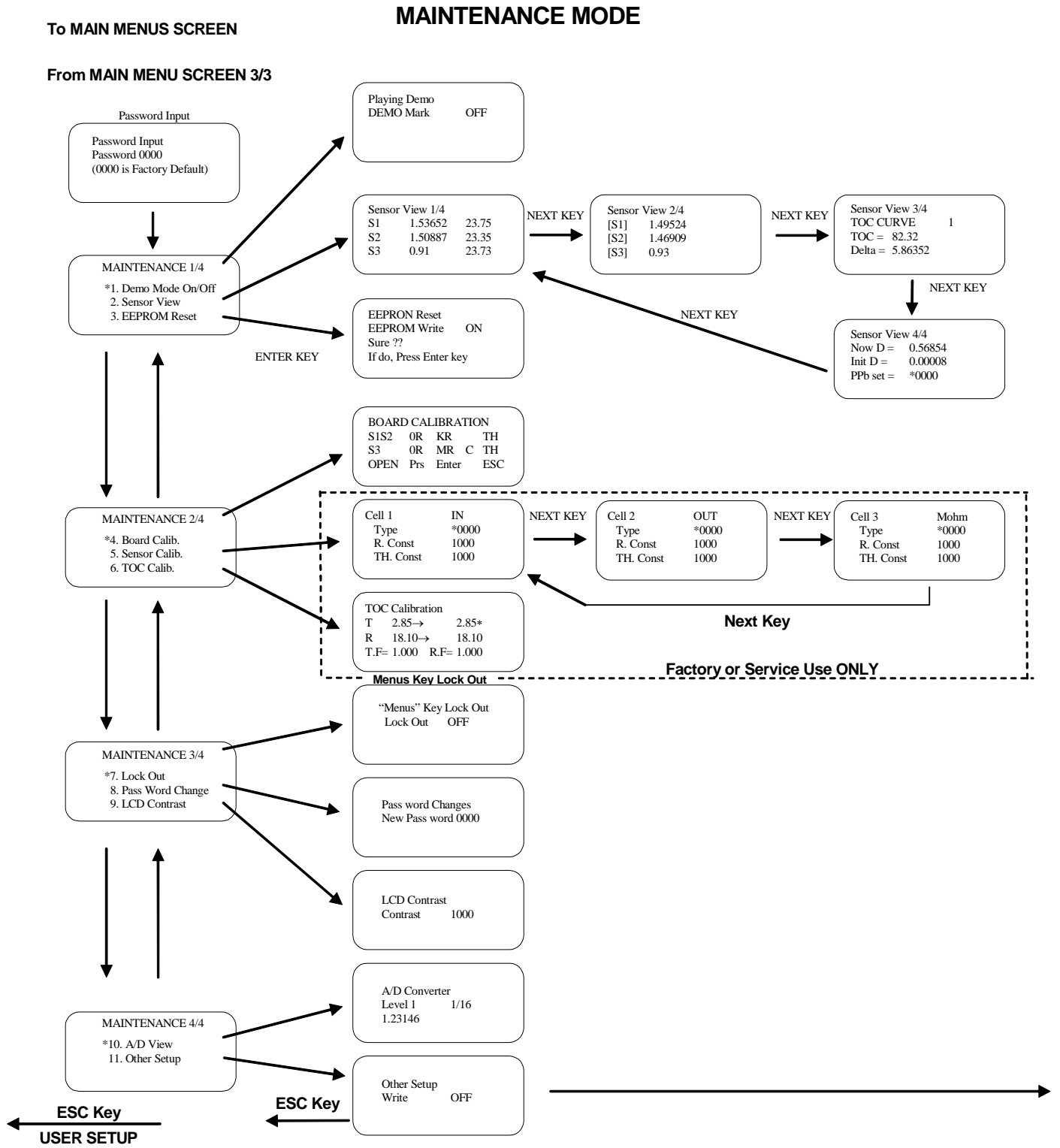

# 550 OPERATION CHART - Maintenance Mode (Other Setup menus)

← **Back to Measurement Mode**  
(Press ESC key three times)

## Other Setup Menus

From previous page →

1. TOC Curve  
TOC Curve \*01  
FLOW Rate 20  
Full Oxidation

### TOC Curve configuration

NEXT

### Initialize Limit Setup

(For Factory or Service use only)

The Calib No.1&2 number is read as 0.010  $\mu$ S/cm.  
See Table in Chapter 8.  
Programmed TOC Curve.

2. INITIALIZE CHANGE  
Calib. No.1 \*0010  
Calib. No.2 0050

NEXT

### Measurement Parameter 1

Designates M $\Omega$ -cm limit value on display.  
Reserve not used.

To change flow rate, see CONFIGURATION

3. MEASURE PARA 1  
Mohm Limitor 1820  
RESERVE 1 0000

NEXT

### Measurement Parameter 2

Multi-functional. See ADVANCED CONFIGURATION.  
Not used.

For enabling or disabling Error 2, see ADVANCED CONFIGURATION.

4. MEASURE PARA 2  
RESERVE 2 0000  
RESERVE 3 1000  
Sensor Status 0000

NEXT

### UV Light Time

ON TIME: total hrs present lamp has been on.

CHG TIME: recommended limit for lamp.

TIME CLR: Sets On Time to zero.

5. UV TIME  
UV ON TIME = \*0020  
UV CHG TIME = 4000  
UV TIME CLR = OFF

NEXT

### TOC OFFSET

For Factory or Service use only.

6. TOC OFFSET  
TOC OFFSET \*0000

NEXT

## OPTIONAL PRINTER DIP SWITCH SETTINGS

Dip Switch Settings for optional Printer model: Seiko DPU414

Software DIP SW1:

Switch No.	Function	Setting	Meaning
1	Input Method	OFF	Serial
2	Printing Speed	ON	High
3	Auto loading	ON	On
4	CR function	OFF	Carriage return
5	DIP SW setting command	ON	Enable
6	Print Density	OFF	100%
7	Print Density	ON	100%
8	Print Density	ON	100%

Software DIP SW2:

Switch No.	Function	Setting	Meaning
1	Print Mode	ON	Normal Printing (40 Columns)
2	User-Defined Characters back-up	ON	On
3	Character type	ON	Ordinary Characters
4	Zero Font	ON	0
5	International Character Set	ON	American
6	International Character Set	ON	American
7	International Character Set	ON	American
8	International Character Set	OFF	American

Software DIP SW3:

Switch No.	Function	Setting	Meaning
1	Data Bit length	ON	8 Bit
2	Parity permission	ON	Without
3	Parity condition	ON	Odd
4	Flow control	ON	H/W BUSY
5	Baud Rate	OFF	9600 bps
6	Baud Rate	ON	9600 bps
7	Baud Rate	ON	9600 bps
8	Baud Rate	ON	9600 bps

# SPECIFICATIONS

---

<b>Ambient Temp/Humidity</b>	5-40 °C / 5-80% RH Non-condensing
<b>Location</b>	Industrial Environment (Indoor)
<b>Display</b>	LCD with back-light, displays TOC, resistivity, temperature, and operation/error indications
<b>Analog outputs</b>	One 4-20mA DC, Output is selectable for TOC or resistivity or temperature
<b>Outputs Alarm outputs</b>	Two SPDT contacts for Hi-Alarm, Lo-Alarm and Error Rated 0.4A @ 120VAC, 2.0A @ 30VDC
<b>Alarms displayed</b>	UV lamp replacement Alarm; Error Alarm (both on LCD)
<b>Voltage / Current</b>	100-240 VAC @ 50 / 60 Hz/50W (max)
<b>Size</b>	12.8" (327 mm) W x 6.6" (167 mm) H x 13.8" (350 mm) D
<b>Weight</b>	17.6 lb. (8 kg)
<b>Sample connections</b>	0.25 in (6 mm) tube fittings
<b>Wetted Parts</b>	316 SS, PVDF, high quality quartz glass
<b>Printer</b>	Thermal, Serial dot (SEIKO Model: DPU414)
<b>Print out</b>	TOC, Resistivity, Temperature, Date and Time
<b>Printer interval</b>	1-99 seconds, 1-99 minutes, 1-99 hours (adjustable in increments of 1)
<b>Power</b>	6 VDC (provided by analyzer)

## TOC Performance

### Model

**Designation** **550-HT**

---

Measurement	0.1-1000 ppb
Range Repeatability	± 0.1 ppb < 10 ppb TOC ± 1% > 10 ppb TOC
Resolution	0.01 ppb
Detection Limit	0.1 ppb
Linearity (Accuracy)*	1.00 ± 0.05
Water Quality**	> 0.5 MΩ-cm < 2.0 μS/cm
Resistivity/ Conductivity***	0.05-18.2 MΩ -cm (0.055-20 μS/cm)

### Sample Water

Temperature	15-90°
Particle Size	< 100 μm
Flow Rate	20 ml/min
Pressure	7-100 psi at Inlet

### Sample Water

MDL (Min. Detection Limit)	0.1 ppb
Temperature Accuracy (RTD in Conductivity sensors)	±0.3°C

\*Values expressed in terms of Slope, defined as TOC recovered vs. TOC injected based on tests performed using samples of known concentrations of organics.

\*\*Designates sample water quality requirements to meet stated TOC performance specifications shown.

\*\*\* Designates range of conductivity measurement only.

## ACCESSORIES AND REPLACEMENT PARTS

---

<b>Part No.</b>	<b>Description</b>
139-003	Thermal Printer, Serial Interface, 6VDC (Supplied with power cord, interface cable with connectors and manufacturers user's manual.)
139-005	Resistor Kit, Board Calibration (550-HT)
129-010	Replacement UV Lamp, 185 nanometer
129-002	Replacement Power Cord, three-prong, 1.5 m (5 ft) long

# **CE DECLARATION OF CONFORMITY**

---

We, Mettler-Toledo Thornton, Inc., 36 Middlesex Turnpike, Bedford, MA 01730 hereby declare, in conjunction with the original equipment manufacturer that all 550 TOC Analyzers to which this declaration relates, is in conformity with the following European, harmonized and published standards at the date of this declaration:

EN 61326	Emissions (EN 55011 Group Class A) and Immunity
IEC 61010-1	Safety (LVD)

This declaration is based on complete test data and technical documentation relating to the tests performed per above standards, as noted.

# DECLARATION OF CSA COMPLIANCE

---

## Declaration of CSA Compliance

Mettler-Toledo Thornton, Inc., 36 Middlesex Turnpike, Bedford, MA 01730 hereby declares that all 550 TOC Analyzers are eligible to bear the official CSA Mark, as shown below, with the adjacent indicators 'C' and 'US' and a Certificate of Compliance from the Canadian Standards Association has been issued and is on file.



Listed below is the detailed information noted on this certificate.

## PRODUCTS

CLASS 2252-03 PROCESS CONTROL EQUIPMENT

CLASS 2252-83 PROCESS CONTROL EQUIPMENT – Certificate to U.S. Standards

## APPLICABLE REQUIREMENTS

CSA Standard C22.2

No. 0-M92 - General Requirements – Canadian Electrical Code, Part II

0.4-M1982 - Bonding and Grounding of Electrical Equipment (Protective Grounding)

1010.1-92 - Safety Requirements of Electrical Equipment for Measurement, Control and Laboratory Use, Part 1: General Requirements (Includes Amendment 1)

1010.1B-97- Amendment 2 to CAN/CSA-C22.2 No. 1010.1-92, "Safety Requirements for Electrical Equipment for Measurement, Control, and Laboratory Use, Part 1: General Requirements"

ANSI/ISA

S82.01-1994- Safety Standards Electrical and Electronic Test, Measuring, Controlling and Related Equipment – General Requirements

TIL I-29A

- Process Control equipment

The 'C' and 'US' indicators adjacent to the CSA Mark signify that the product has been evaluated to the applicable CSA and ANSI/UL standards, for use in Canada and the U.S. respectively. This 'US' indicator includes products eligible to bear the 'NRTL' indicator, i.e. National Recognized Testing Laboratory, is a designation granted by the U.S. Occupational Safety and Health Administration (OSHA) to laboratories which have been recognized to perform certification to U.S. Standards.

# WARRANTY

---

This Warranty is given expressly and in lieu of all other warranties, express or implied. The Buyer agrees that there is no warranty of merchantability and that there are no other warranties, express or implied, which extend beyond the description on the face of this agreement.

Mettler-Toledo Thornton, Inc. (hereinafter referred to as The Company) warrants to the original Buyer each electrode, component, or instrument manufactured and/or sold by The Company to be free from defects in material and workmanship in normal use and service for a period of one (1) year from shipment, unless expressly stated otherwise by the product packaging or expressly agreed to in advance by the Company. The obligation of The Company under this warranty is limited to repair or replacement of the defective product at The Company's discretion. All warranty claims shall be returned to The Company pursuant to The Company's Returned Goods Authorization program. Shipping costs (including return shipping) are the responsibility of The Buyer. The Company assumes no responsibility for any direct or indirect costs associated with removal of defective products, or re-installation of replacement products. The Company shall not be responsible for damage to any electrode, component, or instrument resulting from misuse, negligence, accident or resulting from repairs, alterations, or installations made by any person or firm not duly authorized by The Company. No agent is authorized to assume for The Company any liability except as above set forth. The Company warrants that services will be performed in a workmanlike manner in conformity with standard industry practice. Should any nonconformity be detected within 30 days after the work is completed and prompt notification is made by Buyer in writing to the Company, Company will supply the necessary service, direction, or consultation to correct the nonconformity.

Returned Goods Policy: A Returned Material Authorization (RMA) number must accompany all returned goods. This authorization is obtained by calling our Technical Service (800) 510-7873 or (781) 301-8600. All transportation costs on authorized returns must be prepaid. Authorized replacement parts sent prior to receipt and evaluation of merchandise being returned will be invoiced in full. Credit will be issued only after the returned part is received and evaluated by factory personnel. The Company is not responsible for products returned without proper authorization.

Factory Restocking Charge: Items returned to The Company more than 30 days after shipment will be subject to a 25 % restocking charge, plus any additional charges for refurbishment to salable condition. The Company will not accept returns more than 90 days after shipment, unless returned under warranty or for non-warranty repair.

Special Products: Cancellation or return of special products will not be accepted.

## Disclaimer of Damages:

In no event shall The Company be liable for any type of special consequential, incidental or penal damages, whether such damages arise out of or are a result of breach of contract, warranty, tort (including negligence), strict liability or otherwise. Such damages shall include, but not be limited to loss of profits or revenues, loss of use of the equipment or associated equipment, cost of substitute equipment, facilities, down time costs, increased construction costs or claims of The Buyer's customers or contractors for such damages. The Buyer agrees that in the event of a transfer, assignment, or lease of the equipment sold hereunder The Buyer shall secure for The Company the protection afforded to it in this paragraph.





Mettler-Toledo Thornton, Inc.  
36 Middlesex Turnpike  
Bedford, MA 01730  
Tel. +1-781-301-8600  
Fax +1-781-301-8701  
Toll Free +1-800-510-PURE  
thornton.info@mt.com

[www.mt.com/thornton](http://www.mt.com/thornton) 

---

Part 84428  
Rev.B 02/08