

Bolt Thread Dimensions

The following tables list National Pipe Taper (NPT) dimensions and straight thread dimensions for hex head bolts.

NPT Dimensions

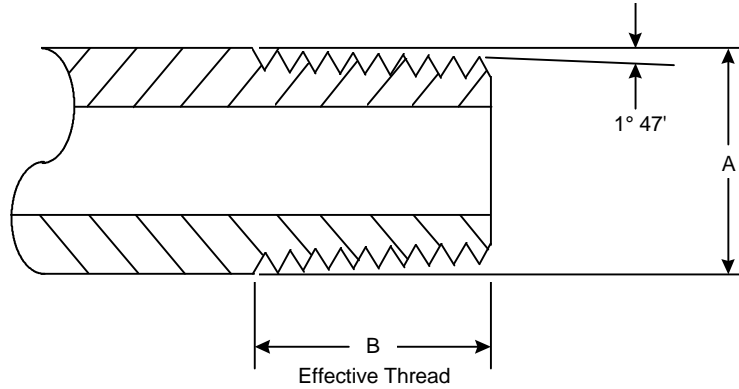

NPT Size	Threads Per Inch	A (inches)	B (inches)
1/16	27	0.312	0.261
1/8	27	0.405	0.264
1/4	18	0.540	0.402
3/8	18	0.675	0.408
1/2	14	0.840	0.534
3/4	14	1.050	0.546
1	11 1/2	1.315	0.683
1 1/4	11 1/2	1.660	0.707

Table 12-6: NPT Dimensions

Straight Thread Dimensions

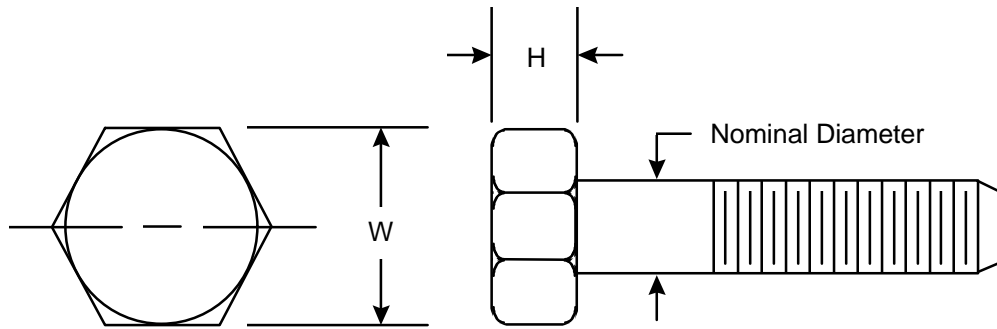

Straight Thread Dimensions (US)

Nominal Thread Size	Threads per Inch		Nominal Diameter	W (inches)	H (inches)
	Coarse (UNC)	Fine (UNF)			
6	32	40	0.1380	-	-
8	32	36	0.1640	-	-
10	24	32	0.1900	-	-
12	24	28	0.2160	-	-
1/4	20	28	0.2500	7/16	11/64
5/16	18	24	0.3125	1/2	7/32
3/8	16	24	0.3750	9/16	1/4
7/16	14	20	0.4375	5/8	19/64
1/2	13	20	0.5000	3/4	11/32
9/16	12	18	0.5625	13/16	3/8
5/8	11	18	0.6250	15/16	27/64
3/4	10	16	0.7500	1 1/8	1/2
7/8	9	14	0.8750	1 5/16	37/64
1	8	12	1.0000	1 1/2	43/64
1 1/8	7	12	1.1250	1 11/16	3/4
1 1/4	7	12	1.2500	1 7/8	27/32
1 3/8	6	12	1.3750	2 1/16	29/32
1 1/2	6	12	1.5000	2 1/4	1

Straight Thread Dimensions (Metric)

Nominal Thread Size*	Thread Pitch (mm)	Nominal Diameter	W (mm)	H (mm)
M3	0.5	3	5.5	2.125
M4	0.7	4	7.0	2.925
M5	0.8	5	8.0	3.650
M6	1	6	10.0	4.150
M8	1.25	8	13.0	5.650
M10	1.5	10	17.0	7.180
M12	1.75	12	19.0	8.180
(M14)	2	14	22.0	9.180
M16	2	16	24.0	10.180
(M18)	2.5	18	27.0	12.215
M20	2.5	20	30.0	13.215
(M22)	2.5	22	32.0	14.215
M24	3	24	36.0	15.215
(M27)	3	27	41.0	17.215
M30	3.5	30	46.0	19.260
(M33)	3.5	33	50.0	21.260
M36	4	36	55.0	23.260
(M39)	4	39	60.0	25.260

*Thread sizes shown in parentheses are not preferred.

Table 12-7: Straight Thread Dimensions