

# Pipette Calibration Balances

XPR26PC

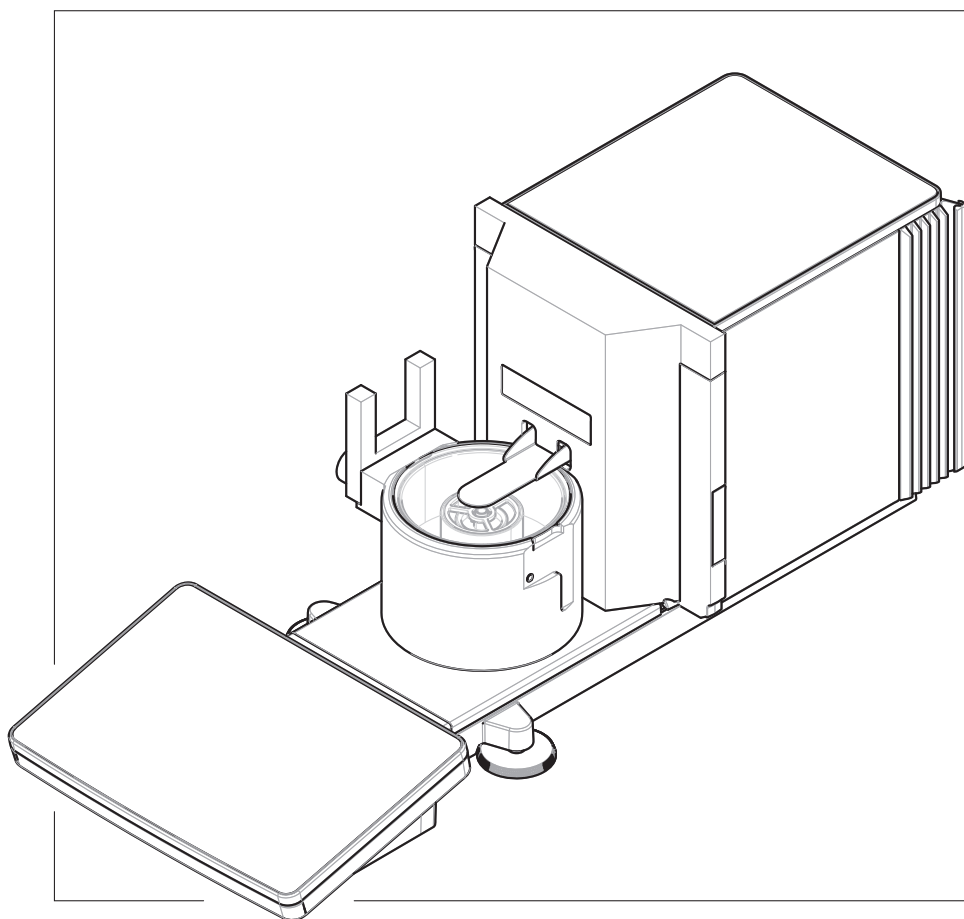

**METTLER TOLEDO**



# Table of Contents

<b>1</b>	<b>Introduction</b>	<b>7</b>
1.1	Further documents and information .....	7
1.2	Explanation of conventions and symbols used .....	7
1.3	Acronyms and abbreviations .....	7
1.4	Product range .....	8
1.4.1	XPR26PC balance .....	8
1.5	Compliance information .....	8
<b>2</b>	<b>Safety Information</b>	<b>10</b>
2.1	Definitions of signal words and warning symbols .....	10
2.2	Product-specific safety information .....	10
<b>3</b>	<b>Design and Function</b>	<b>12</b>
3.1	Function description .....	12
3.2	Overview balance .....	13
3.3	Components description .....	13
3.3.1	Pipetting container .....	13
3.3.2	Drip tray .....	14
3.3.3	Evaporation trap .....	14
3.3.4	Light barrier .....	14
3.3.5	Leveling feet .....	14
3.3.6	Terminal .....	15
3.4	Overview terminal .....	15
3.5	Overview type label .....	16
3.6	User interface .....	16
3.6.1	Main sections at a glance .....	16
3.6.2	Main weighing screen .....	17
3.6.3	Panel "Balance menu" .....	18
3.6.4	Panel "Methods" .....	18
3.6.5	Panel "Results" .....	19
3.6.6	Icons and symbols .....	20
3.6.6.1	System status icons .....	20
3.6.6.2	Weighing status icons .....	20
3.6.6.3	Process status icons .....	21
<b>4</b>	<b>Installation and Putting into Operation</b>	<b>22</b>
4.1	Selecting the location .....	22
4.2	Unpacking the balance .....	22
4.3	Scope of delivery .....	24
4.3.1	Balance .....	24
4.3.2	Documentation .....	24
4.3.3	Calibration kit .....	24
4.4	Installation .....	25
4.4.1	Attaching the terminal .....	25
4.4.2	Assembling the balance .....	26
4.5	Putting into operation .....	27
4.5.1	Connecting the balance .....	27
4.5.2	Switching on the balance .....	28
4.5.3	Logging in .....	28
4.5.4	Leveling the balance .....	29
4.5.5	Performing an internal adjustment .....	29
4.5.6	Performing a function check .....	29
4.5.6.1	Using the small weighing pan .....	29
4.5.6.2	Using the large weighing pan .....	30
4.5.7	Entering / Exiting standby mode .....	30

4.5.8	Switching off the balance .....	31
4.6	Performing a pipetting cycle .....	31
4.6.1	Filling the evaporation trap container .....	31
4.6.2	Zeroing the balance .....	31
4.6.3	Taring the balance .....	32
4.6.4	Performing a pipetting cycle .....	32
4.6.5	Completing the weighing .....	32
4.6.6	Emptying the pipetting container .....	32
4.7	Transporting, packing and storing .....	33
4.7.1	Transporting the balance over short distances .....	33
4.7.2	Transporting the balance over long distances .....	33
4.7.3	Packing and storing .....	33
<b>5</b>	<b>Operation</b> .....	<b>34</b>
5.1	Touch screen .....	34
5.1.1	Selecting or activating an item .....	34
5.1.2	Scrolling .....	34
5.1.3	Using the fly-in panels .....	34
5.1.4	Entering characters and numbers .....	35
5.1.5	Changing the date and time .....	35
5.2	Methods .....	36
5.2.1	Methods overview .....	36
5.2.2	Method "General weighing" .....	36
5.2.2.1	Creating a method "General weighing" .....	37
5.2.2.2	Performing a "General weighing" .....	37
5.2.3	Editing a method .....	38
5.2.4	Cloning a method .....	39
5.2.5	Deleting a method .....	39
5.2.6	Deleting a task .....	39
5.2.7	Using methods with multiple weighing items (itemized) .....	39
5.2.7.1	Creating a new method with multiple weighing items (itemized) .....	40
5.2.7.2	Creating an itemized method from a completed task .....	40
5.2.7.3	Performing an itemized method .....	40
5.3	Test weights .....	40
5.3.1	Defining an individual test weight .....	40
5.3.2	Defining a combined test weight .....	41
5.4	Tests .....	41
5.4.1	Overview routine tests .....	41
5.4.1.1	Repeatability test .....	41
5.4.1.2	Sensitivity test .....	42
5.4.2	Creating a new test .....	42
5.4.3	Preparing the balance for a test .....	42
5.4.3.1	Preparing the balance .....	42
5.4.3.2	Installing the small weighing pan .....	43
5.4.3.3	Installing the large weighing pan .....	43
5.4.4	Performing a test .....	44
5.4.4.1	Performing a "Repeatability test" .....	45
5.4.4.2	Performing a "Sensitivity test" .....	46
5.4.5	Editing a test .....	47
5.4.6	Printing test results .....	47
5.4.7	Deleting a test .....	48
5.4.8	Consulting the test history .....	48
5.5	Adjustments .....	48
5.5.1	Internal adjustment .....	48
5.5.1.1	Editing an "Internal adjustment" .....	48
5.5.1.2	Performing an "Internal adjustment" .....	48
5.5.2	External adjustment .....	49
5.5.2.1	Editing an "External adjustment" .....	49



5.5.2.2	Performing an "External adjustment" .....	49
5.5.3	Consulting the adjustment history .....	50
5.6	Peripheral devices .....	50
5.6.1	Printer .....	50
5.6.1.1	Printing results manually on a strip printer via USB .....	50
5.6.1.2	Printing results automatically on a label printer via Bluetooth .....	52
5.6.2	RFID reader .....	54
5.6.2.1	Reading data from an RFID Smart Tag using an EasyScan USB .....	54
5.6.2.2	Formatting an RFID Smart Tag using an EasyScan .....	55
5.6.3	Foot switch and ErgoSens .....	55
5.6.3.1	Taring the balance with an ErgoSens .....	56
5.6.4	Editing the settings of a device .....	56
5.6.5	Deleting a device .....	56
5.7	Remote control via services .....	57
5.7.1	LabX service .....	57
5.7.1.1	Using LabX via a USB connection .....	57
5.7.1.2	Using LabX via an Ethernet connection .....	57
5.7.2	MT-SICS service .....	58
5.7.2.1	Using MT-SICS via a USB connection .....	58
5.7.2.2	Using MT-SICS via an Ethernet connection .....	58
5.7.3	Web service .....	59
5.8	Data management .....	60
5.8.1	Exporting results .....	60
5.8.2	Sending individual results to a computer .....	61
5.8.3	Exporting and importing settings .....	62
5.8.3.1	Transferring test weight settings between balances .....	63
5.9	User management .....	64
5.9.1	Activating the user management .....	64
5.9.2	Disabling the user management .....	64
5.9.3	Managing users and user groups .....	64
5.9.3.1	Creating a new user .....	65
5.9.3.2	Creating a new group .....	65
5.9.3.3	Deleting users or user groups .....	65
5.10	Tolerance profiles .....	66
5.11	Password protection and balance reset .....	66
5.11.1	Password protection .....	66
5.11.1.1	Changing a password .....	66
5.11.1.2	Requesting a reset password .....	66
5.11.1.3	Creating an unblocking password .....	67
5.11.2	Logging in and logging out .....	67
5.11.2.1	Logging in .....	67
5.11.2.2	Logging out .....	67
5.11.3	Blocking and unblocking the balance .....	67
5.11.3.1	Blocking the balance .....	67
5.11.3.2	Unblocking the balance .....	68
5.11.4	Resetting the balance .....	68
5.12	Automated dosing .....	68
5.12.1	Managing the dosing head data .....	68
5.12.2	Changing the pump pressure .....	70

<b>6</b>	<b>Software Description</b> .....	<b>71</b>
6.1	Balance menu settings .....	71
6.1.1	Leveling aid .....	71
6.1.2	History .....	71
6.1.2.1	Adjustments .....	71
6.1.2.2	Tests .....	72
6.1.2.3	Service .....	72
6.1.2.4	Changes .....	72

6.1.3	Balance info.....	73
6.1.4	Users.....	73
6.1.4.1	General.....	73
6.1.4.2	Users.....	74
6.1.4.3	Groups.....	74
6.1.5	Settings.....	75
6.1.5.1	Balance.....	76
6.1.5.2	Modules / Dosing.....	83
6.1.5.3	Interfaces.....	84
6.1.5.4	Devices / Printers.....	85
6.1.5.5	LabX / Services.....	86
6.1.5.6	Printing the settings.....	87
6.1.6	Maintenance.....	87
6.1.6.1	Service menu.....	87
6.2	Weighing methods settings.....	88
6.2.1	Settings: method "General weighing".....	88
6.2.1.1	General.....	89
6.2.1.2	ID format.....	89
6.2.1.3	Weighing.....	90
6.2.1.4	Weighing item / Weighing items.....	91
6.2.1.5	Automation.....	92
6.2.1.6	Print / Export.....	94
6.3	Test weights settings.....	99
6.3.1	Settings: individual test weight.....	99
6.3.2	Settings: combined test weight.....	99
6.4	Tests settings.....	100
6.4.1	Settings: Repeatability test.....	100
6.4.2	Settings: Sensitivity test.....	103
6.5	Adjustments settings.....	106
<b>7</b>	<b>Maintenance</b> .....	<b>109</b>
7.1	Maintenance tasks.....	109
7.2	Emptying the containers.....	110
7.2.1	Assembling the pump.....	110
7.2.2	Emptying the pipetting container.....	110
7.2.3	Emptying the evaporation trap container.....	111
7.3	Cleaning.....	112
7.3.1	Disassembling for cleaning.....	112
7.3.2	Cleaning agents.....	113
7.3.3	Cleaning the balance.....	114
7.3.4	Cleaning after an overflow.....	115
7.3.5	Putting into operation after cleaning.....	115
7.4	Service.....	115
7.5	Software update.....	115
7.5.1	Updating the software.....	116
7.5.2	Restoring the software to the previous version.....	116
7.5.3	Putting into operation after software update.....	116
<b>8</b>	<b>Troubleshooting</b> .....	<b>117</b>
8.1	Error messages.....	117
8.2	Error symptoms.....	117
8.3	Putting into operation after fixing an error.....	119
<b>9</b>	<b>Technical Data</b> .....	<b>120</b>
9.1	General data.....	120
9.2	Explanatory notes for the METTLER TOLEDO AC/DC adapter.....	121
9.3	Model-specific data.....	122
9.4	Dimensions.....	123

<b>10</b>	<b>Disposal</b>	<b>124</b>
<b>11</b>	<b>Accessories and Spare Parts</b>	<b>125</b>
11.1	Accessories .....	125
11.2	Spare parts.....	130
11.2.1	Balance .....	130
11.2.2	Pump .....	131
11.2.3	Miscellaneous .....	132
11.2.4	Packaging .....	133
<b>12</b>	<b>Appendix</b>	<b>134</b>
12.1	Approved balances.....	134
12.1.1	Definitions.....	134
12.1.2	Descriptive markings.....	134
12.1.3	Restrictions on zeroing and taring.....	134
12.1.4	Factory method: General Weighing .....	134
12.1.5	Representation of weighing results .....	135
12.1.6	MT-SICS.....	136
12.1.7	Reference.....	136
	<b>Index</b>	<b>137</b>



# 1 Introduction

Thank you for choosing a METTLER TOLEDO balance. The balance combines high performance with ease of use.

This document is based on the software version V 2.0.501.

## EULA

The software in this product is licensed under the METTLER TOLEDO End User License Agreement (EULA) for Software.

When using this product you agree to the terms of the EULA.

▶ [www.mt.com/EULA](http://www.mt.com/EULA)

## 1.1 Further documents and information

This document is available in other languages online.

▶ [www.mt.com/XPR26PC-RM](http://www.mt.com/XPR26PC-RM)

Product page:

▶ [www.mt.com/pipcal](http://www.mt.com/pipcal)

Instructions for cleaning a balance, "8 Steps to a Clean Balance":

▶ [www.mt.com/lab-cleaning-guide](http://www.mt.com/lab-cleaning-guide)

Search for software:

▶ [www.mt.com/labweighing-software-download](http://www.mt.com/labweighing-software-download)

Search for documents:

▶ [www.mt.com/library](http://www.mt.com/library)

For further questions, please contact your authorized METTLER TOLEDO dealer or service representative.

▶ [www.mt.com/contact](http://www.mt.com/contact)

## 1.2 Explanation of conventions and symbols used

### Conventions and symbols

Key and/or button designations and display texts are shown in graphic or bold text, e.g., , **Edit**.

 **Note** For useful information about the product.



Refers to an external document.

### Elements of instructions

In this manual, step-by-step instructions are presented as follows. The action steps are numbered and can contain prerequisites, intermediate results and results, as shown in the example. Sequences with less than two steps are not numbered.

■ Prerequisites that must be fulfilled before the individual steps can be executed.

1 Step 1

➔ Intermediate result

2 Step 2

➔ Result

## 1.3 Acronyms and abbreviations

Original term	Explanation
AC	Alternating Current
ASTM	American Society for Testing and Materials

DC	Direct Current
EMC	Electromagnetic Compatibility
FCC	Federal Communications Commission
GWP	Good Weighing Practice
HID	Human Interaction Device
ID	Identification
LED	Light-Emitting Diode
LPS	Limited Power Source
MAC	Media Access Control
MT-SICS	METTLER TOLEDO Standard Interface Command Set
NA	Not Applicable
OIML	Organisation Internationale de Métrologie Légale (International Organization of Legal Metrology)
RAM	Random Access Memory
RFID	Radio-frequency identification
RM	Reference Manual
SELV	Safety Extra Low Voltage
SOP	Standard Operating Procedure
SQC	Statistical Quality Control
UM	User Manual
USB	Universal Serial Bus
USP	United States Pharmacopeia

## 1.4 Product range

### 1.4.1 XPR26PC balance

Balance	Models designation
	Readability: <b>0.001 mg</b> <ul style="list-style-type: none"> <li>• XPR26PC</li> </ul>

## 1.5 Compliance information

National approval documents, e.g., the FCC Supplier Declaration of Conformity, are available online and/or included in the packaging.

► [www.mt.com/ComplianceSearch](http://www.mt.com/ComplianceSearch)

Contact METTLER TOLEDO for questions about the country-specific compliance of your instrument.

► [www.mt.com/contact](http://www.mt.com/contact)

### United States of America

This equipment has been tested and found to comply with the limits for a **Class A** digital device, pursuant to part 15 of the FCC Rules. These limits are designed to provide reasonable protection against harmful interference when the equipment is operated in a commercial environment. This equipment generates, uses, and can radiate radio frequency energy and, if not installed and used in accordance with the instruction manual,

may cause harmful interference to radio communications. Operation of this equipment in a residential area is likely to cause harmful interference in which case the user will be required to correct the interference at his own expense.

This device complies with Part 15 of the FCC Rules. Operation is subject to the following two conditions:

1. This device may not cause harmful interference.
2. This device must accept any interference received, including interference that may cause undesired operation.

Changes or modifications not expressly approved by the party responsible for compliance could void the user's authority to operate the equipment.

## 2 Safety Information

Two documents named "User Manual" and "Reference Manual" are available for this instrument.

- The User Manual is printed and delivered with the instrument.
- The electronic Reference Manual contains a full description of the instrument and its use.
- Keep both documents for future reference.
- Include both documents if you transfer the instrument to other parties.

Only use the instrument according to the User Manual and the Reference Manual. If you do not use the instrument according to these documents or if the instrument is modified, the safety of the instrument may be impaired and Mettler-Toledo GmbH assumes no liability.

### 2.1 Definitions of signal words and warning symbols

Safety notes contain important information on safety issues. Ignoring the safety notes may lead to personal injury, damage to the instrument, malfunctions and false results. Safety notes are marked with the following signal words and warning symbols:

#### Signal words

<b>DANGER</b>	A hazardous situation with high risk, resulting in death or severe injury if not avoided.
<b>WARNING</b>	A hazardous situation with medium risk, possibly resulting in death or severe injury if not avoided.
<b>CAUTION</b>	A hazardous situation with low risk, resulting in minor or moderate injury if not avoided.
<b>NOTICE</b>	A hazardous situation with low risk, resulting in damage to the instrument, other material damage, malfunctions and erroneous results, or loss of data.

#### Warning symbols



General hazard



Notice

### 2.2 Product-specific safety information

#### Intended use

This instrument is designed to be used by trained staff. The instrument is intended for weighing purposes. Any other type of use and operation beyond the limits of use stated by Mettler-Toledo GmbH without consent from Mettler-Toledo GmbH is considered as not intended.

#### Responsibilities of the instrument owner

The instrument owner is the person holding the legal title to the instrument and who uses the instrument or authorizes any person to use it, or the person who is deemed by law to be the operator of the instrument. The instrument owner is responsible for the safety of all users of the instrument and third parties.

Mettler-Toledo GmbH assumes that the instrument owner trains users to safely use the instrument in their workplace and deal with potential hazards. Mettler-Toledo GmbH assumes that the instrument owner provides the necessary protective gear.



## Safety notes



### **WARNING**

#### **Death or serious injury due to electric shock**

Contact with parts that carry a live current can lead to death or injury.

- 1 Only use the METTLER TOLEDO power cable and AC/DC adapter designed for your instrument.
- 2 Connect the power cable to a grounded power outlet.
- 3 Keep all electrical cables and connections away from liquids and moisture.
- 4 Check the cables and the power plug for damage and replace them if damaged.



### **NOTICE**

#### **Damage to the instrument or malfunction due to the use of unsuitable parts**

- Only use parts from METTLER TOLEDO that are intended to be used with your instrument.

## 3 Design and Function

### 3.1 Function description

The XPR line comprises a range of balances that differ from each other due to their weighing range and resolution. The balances of the XPR line combine a large number of weighing and adjustment possibilities with a simple operation handling.

For the XPR26PC model, the following features are available:

- fully automatic adjustment using internal weights
- built-in level sensor and leveling aid for fast and easy leveling
- 7-inch capacitive color TFT-touch screen
- various methods that can be defined individually
- various routine tests that can be defined individually
- functions to manage user groups and user rights
- history about performed tests and adjustments, as well as changes applied to the balance settings
- motor-driven evaporation trap door
- easily removable evaporation trap
- light barrier for touchless operation of the evaporation trap door

The XPR26PC model is designed to work in conjunction with Calibry, a pipette calibration software optimized for METTLER TOLEDO instruments, see [Accessories ► Page 128]. Calibry almost completely automates the handling of the XPR26PC balance and allows for easy, fast, and cost-efficient monitoring of single- and multi-channel pipettes according to ISO8655, manufacturer tolerances, or customer SOPs. The software guides you step by step through the calibration process and generates reports.

## 3.2 Overview balance

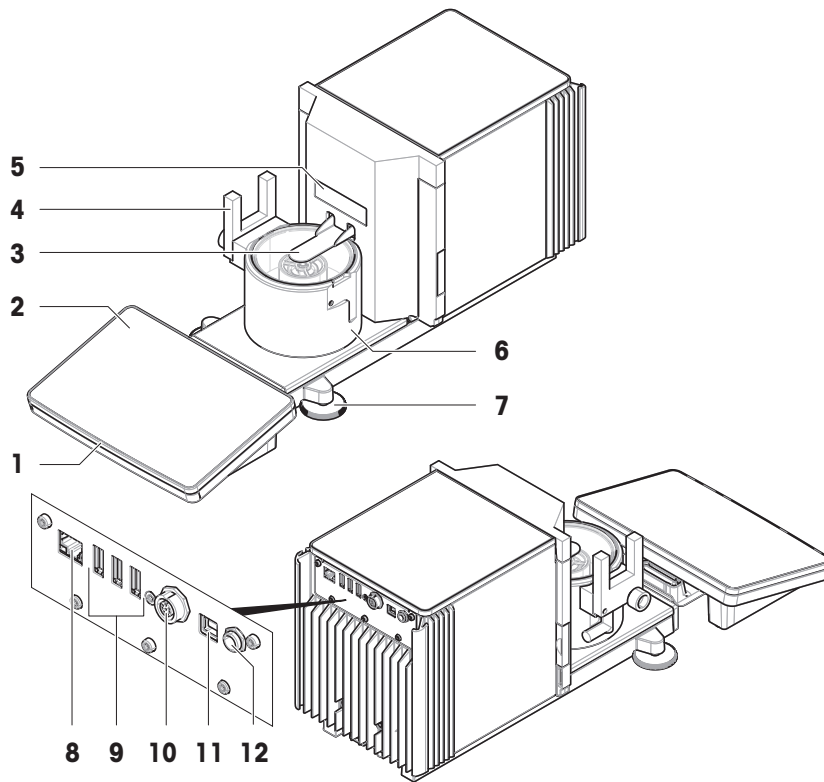

<b>1</b>	StatusLight	<b>7</b>	Leveling feet
<b>2</b>	Terminal	<b>8</b>	Ethernet port
<b>3</b>	Evaporation trap door	<b>9</b>	USB-A ports (to device)
<b>4</b>	Light barrier	<b>10</b>	Socket for terminal connection cable
<b>5</b>	Model label	<b>11</b>	USB-B port (to host)
<b>6</b>	Pipetting base	<b>12</b>	Socket for AC/DC adapter

## 3.3 Components description

### 3.3.1 Pipetting container

The pipetting container is the load receptor into which the water is pipetted.

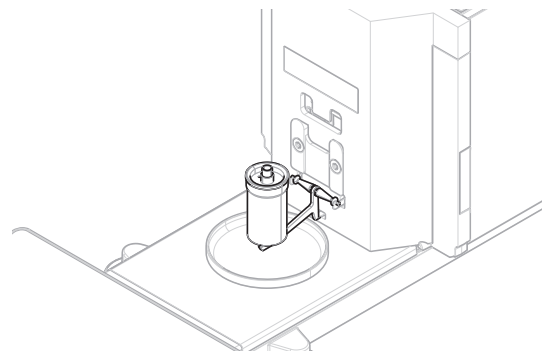

### 3.3.2 Drip tray

The drip tray is positioned below the pipetting container, on the base plate of the weighing unit. The primary purpose of the drip tray is to ensure quick cleaning of the balance.

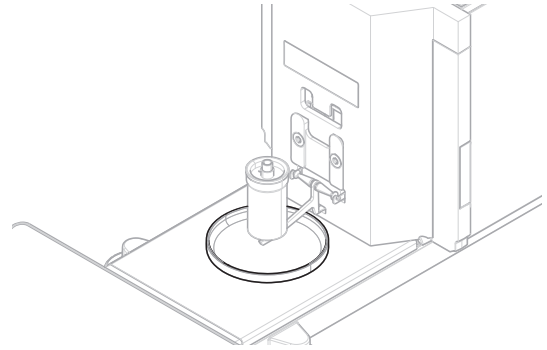

### 3.3.3 Evaporation trap

The evaporation trap includes a container that should be filled with water. When the evaporation trap is closed, the humidity inside increases until the air is saturated. This prevents evaporation of the liquid in the pipetting container and ensures accurate weighing results.

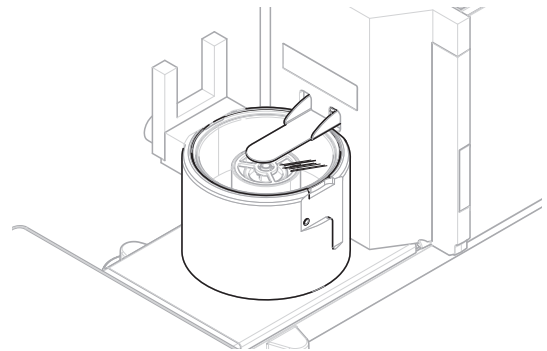

### 3.3.4 Light barrier

The light barrier is attached to the left side or the right side of the pipetting base. When the light barrier is activated, the evaporation trap door opens or closes.

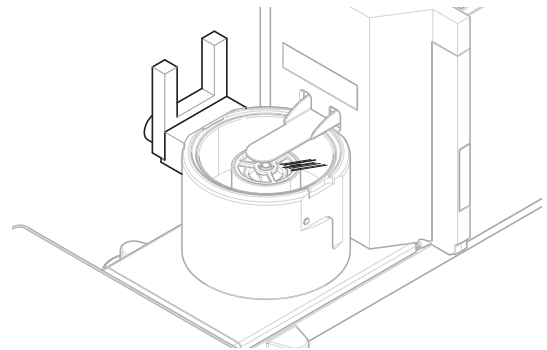

### 3.3.5 Leveling feet

The balance stands on two height-adjustable feet. These feet are used to level the balance.

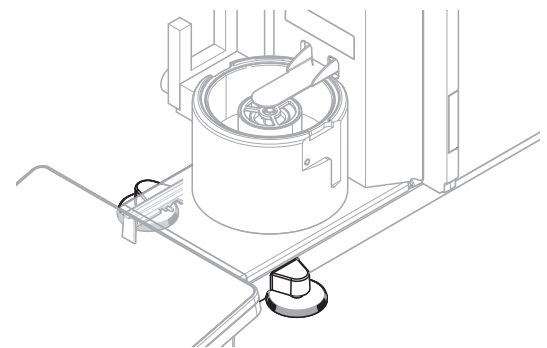





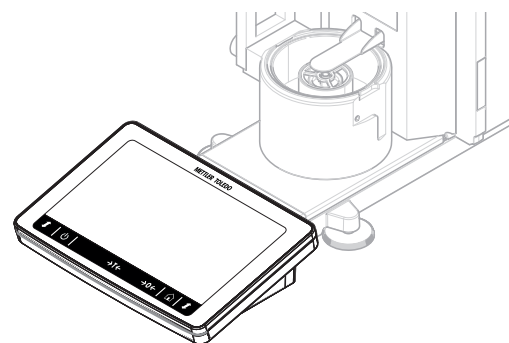

### 3.3.6 Terminal

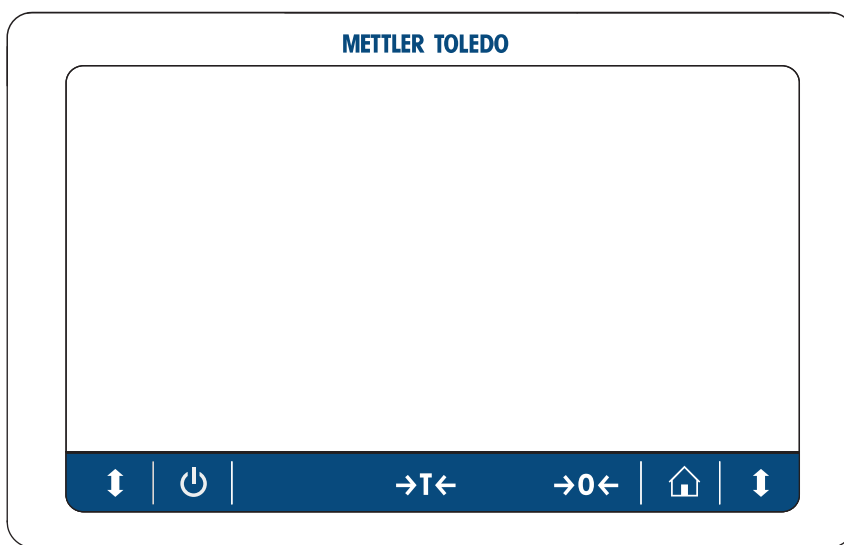
The 7-inch balance terminal has a touch-sensitive display. Further, on the front side of the terminal is a StatusLight LED strip that indicates the current status of the balance.



### 3.4 Overview terminal



	Name	Description
	Standby	By tapping  , the balance is not completely switched off but goes into standby mode. To switch the balance completely off, it must be unplugged from the power supply.  <b>Note</b> Do not disconnect the balance from the power supply unless the balance is not used for an extended period of time. After switching on the instrument, it must warm up before giving accurate results.
	Tare	Tares the balance.  This function is used between subsequent measurements. After taring the balance, the screen shows <i>Net</i> which indicates that all displayed weights are net.
	Zero	Zeroes the balance.  The balance must always be zeroed before starting the weighing process. After zeroing, the balance sets a new zero point.
	Home	To return from any menu level to the main weighing screen.
	Open/close door	Opens or closes the evaporation trap door.

### 3.5 Overview type label

The information on the type label helps to identify the balance and terminal.

#### Type label of the terminal

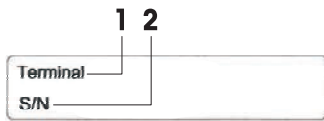

1. Terminal type
2. Terminal serial number

#### Type label of the balance

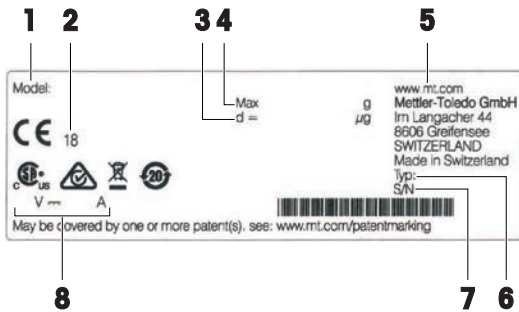

1. Balance model
2. Year of manufacture
3. Readability
4. Maximum capacity
5. Manufacturer
6. Balance type
7. Balance serial number
8. Power consumption

### 3.6 User interface

#### 3.6.1 Main sections at a glance

The main weighing screen (1) is the central navigation point where all the menus and settings can be found. The **Balance menu** (2), **Methods** (3) and **Results** (4) open when tapping the tabs along the sides of the main weighing screen.

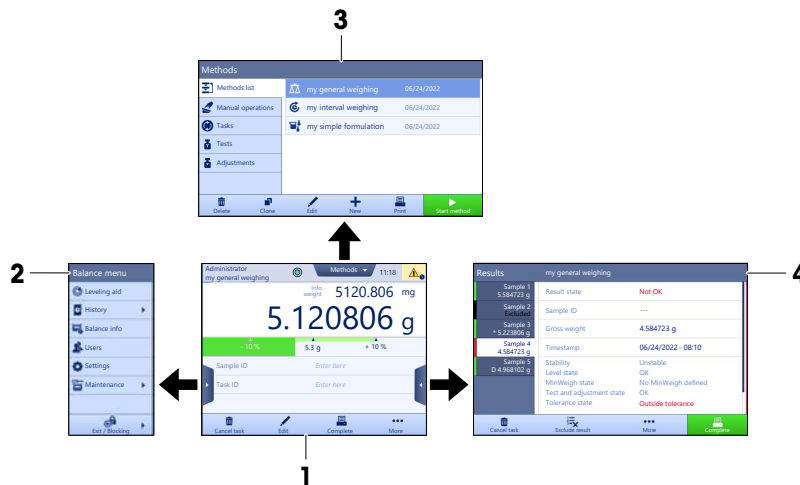

#### See also

- [Main weighing screen](#) ▶ Page 17
- [Panel "Balance menu"](#) ▶ Page 18
- [Panel "Methods"](#) ▶ Page 18
- [Panel "Results"](#) ▶ Page 19

### 3.6.2 Main weighing screen



	Name	Description
1	<b>User name</b>	Shows the name of the current user.
2	Weighing value field	Shows the current weighing value.
3	Level indicator	Indicates if the balance is leveled (green) or not (red).
4	<b>Methods</b> menu	Accesses the user-defined list of methods, tests, and alignments.
5	<b>Info weight</b>	Shows the current weighing value in another unit.
6	Warning and error message area	Shows current warning and/or error messages.
7	<b>Results list</b>	Shows the weighing results saved for this task.
8	Sample status <b>OK</b>	Result status indicator green: indicates that the result fulfills a set of criteria. For example: <ul style="list-style-type: none"> <li>The balance is in level.</li> <li>The internal adjustment was performed and ok.</li> <li>The weighing result is within the defined tolerance range (only if tolerance is defined).</li> </ul>
9	Sample status <b>Excluded</b>	Result status indicator black: indicates that the result was excluded from the <b>Results list</b> .
10	Sample status <b>Not OK</b>	Result status indicator red: indicates that the result criteria are not fulfilled, e.g., "The weighing result was out of the defined tolerances".
11	Button <b>Add result</b>	Adds the result to the <b>Results list</b> . Depending on the selected method, the button can have different functions.
12	Action bar	Contains actions referring to the current task.
13	<b>Balance menu</b>	Accesses the balance properties.
14	Method information area	Contains information about the sample, method or task IDs.
15	SmartTrac	Used as a weighing aid to define a target weight with upper and lower tolerances.
16	Weighing value area	Shows the results of the current weighing process.
17	<b>Method name</b>	Shows the name of the current method.

### 3.6.3 Panel "Balance menu"

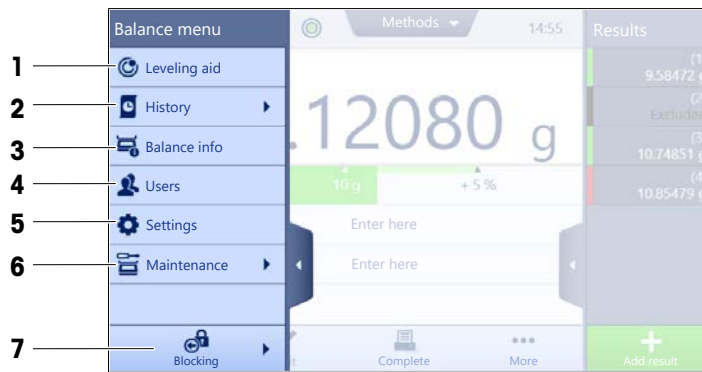

	Name	Description
1	<b>Leveling aid</b>	Opens the leveling dialog.
2	<b>History</b>	Opens the history dialog.
3	<b>Balance info</b>	Shows the balance information.
4	<b>Users</b>	Opens the user management.
5	<b>Settings</b>	Opens the complete settings dialog.
6	<b>Maintenance</b>	Opens the balance maintenance dialog.
7	<b>Exit / Block balance</b>	Opens the logout / block balance dialog.

### 3.6.4 Panel "Methods"



	Name	Description
1	<b>Methods list</b>	Lists the methods already defined by the user. Methods can be created, edited, cloned, started, or deleted.
2	<b>Manual operations</b>	For automated weighing, this menu shows operations that can be performed manually. Depending on the available hardware, this can include: <ul style="list-style-type: none"> <li>• <b>Manage dosing head data</b></li> </ul>
3	<b>Tasks</b>	A method/task can be started and then a task is associated with this method. There can be up to one task for each method.
4	<b>Tests</b>	Lists the tests already defined by the user. <ul style="list-style-type: none"> <li>• Sensitivity tests</li> <li>• Repeatability tests</li> <li>• Eccentricity tests</li> </ul> Routine tests can be created, edited, started, or deleted. A list of the tests previously performed is available in the <b>History</b> .



	Name	Description
5	Adjustments	Shows the currently selected internal or external adjustment. The adjustment can be edited or started. A list of the adjustments previously performed is available in the <b>History</b> .

### See also

[History](#) ▶ Page 71

## 3.6.5 Panel "Results"







	Name	Description
1	Result state	Shows the state of the weighing process.
2	Sample ID	Shows the <b>Sample ID</b> of the weighing.
3	Gross weight	Shows the gross weight. <b>D</b> : indicates that the value was unstable. This might occur when the <b>Weighing mode</b> is set to <b>Immediate</b> . <b>*</b> : indicates that the value was calculated. This might occur, for example, when the <b>Tare Mode</b> is set to <b>Preset tare</b> .
4	Timestamp	Shows the individual timestamp of each weighing item.
5	Balance status	Shows stability, level state of the balance, minimum weight, tolerance state and test and adjustment state.
6	Complete	Opens the dialog <b>Complete task</b> . <ul style="list-style-type: none"> <li>• <b>Print task label manually</b></li> <li>• <b>Print results manually</b></li> <li>• <b>Export results manually</b></li> </ul>
7	More	Opens the dialog <b>More</b> . <ul style="list-style-type: none"> <li>• <b>Start adjustment</b></li> <li>• <b>Change display unit</b></li> <li>• <b>Configure tare</b></li> <li>• <b>Configure zero</b></li> <li>• <b>Save as method (itemized)</b> (only available for methods with the option <b>Weighing items</b>)</li> </ul>
8	Exclude result	Excludes the current result from the <b>Results list</b> . A comment can be added to the excluded result, e.g., to describe the reason of the exclusion. Depending on the format of the results printout, the excluded result can be printed or not.

	Name	Description
9	Cancel task	Cancels the current running task.

### 3.6.6 Icons and symbols







#### 3.6.6.1 System status icons

System messages can appear due to a user action, a user input or a system process. Some messages leave it up to the user to choose upon acting, they will disappear after acknowledging. Other messages remain persistent, so the user can defer them but eventually has to handle them. These messages can be seen in the main status bar on the upper right-hand side of the display.

Icon	Name	Description
	Levelled	More details about the leveling status are displayed when tapping the level status.
	Out of level	The balance must be leveled. Information about leveling the balance can be found in the section Leveling the balance.
	Information	Information messages appear due to user actions or system processes and offer opportunities that are related to the current action or process.
	Warning	Warning messages appear due to user actions or system processes that could lead to a problem that can be prevented.
	Error	Error messages appear due to user actions or system processes that have failed. It is mostly still possible to handle such a problem.





#### 3.6.6.2 Weighing status icons

Weighing status icons appear due to the weight value matching certain quality criteria. The information on the status can be looked by tapping on any of the visible weighing status icons.

Icon	Name	Description
	Stability indicator	When the stability indicator appears, the balance is not stable. Make sure that the balance is placed at an adequate location. Information about the adequate location can be found in the section Selecting the location.
Net	Net indicator	Appears when the tare key has been pressed and the tare weight has been subtracted.
	Calculated value	The current weight value is calculated. This symbol only appears in the weighing value area when a container has been used with the function <b>Preset tare</b> .
	Minimum weight violation	The current weight value is smaller than the defined minimum weight. Make sure that the weight is larger than the minimum weight.
	Balance invalid	The current balance configuration is invalid or quality criteria have not been fulfilled according to the GWP approved definition.
	Weight not ready	The current weight measurement is not ready according to the GWP approved definition. This can be caused by an overload, an underload, or a minimum weight violation.
	Weight ready	The current weight measurement is ready according to the GWP approved definition. It can be added to the <b>Results list</b> .
	External ionizer discharging	The external ionizer is currently discharging.

### 3.6.6.3 Process status icons

The status of the processes running on the balance is indicated by a small icon on the bottom right corner of the icon of the associated process. This applies to **Tasks**, **Tests**, and **Adjustments**.

Icon	Name	Description
	Running	The process is currently running.
	Paused	The process is paused.
	Scheduled	The process is scheduled.
	Information	Information is available about the process, e.g., a reminder.
	Overdue	The process is overdue.

## 4 Installation and Putting into Operation

### 4.1 Selecting the location

A balance is a sensitive precision instrument. The location where it is placed will have a profound effect on the accuracy of the weighing results.

#### Requirements of the location

Place indoors on stable table



Avoid direct sunlight

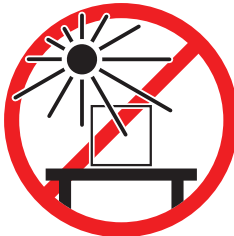

Ensure sufficient spacing

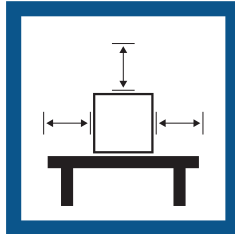

Avoid vibrations



Level the instrument



Avoid strong drafts



Provide adequate lighting

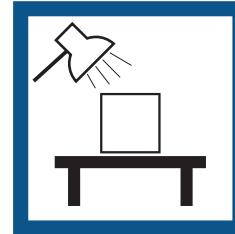

Avoid temperature fluctuations



Sufficient spacing for balances: > 15 cm all around the instrument

Take into account the environmental conditions. See "Technical Data".

### 4.2 Unpacking the balance

Check the package, the packaging elements and the delivered components for damages. If any components are damaged, please contact your METTLER TOLEDO service representative.

- 1 Open the box and lift the package out using the lifting strap (1).

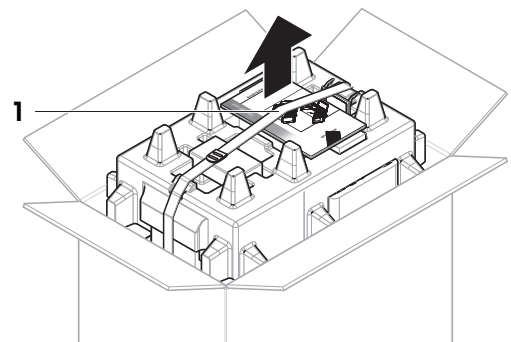

- 2 Open the lifting strap (1) and remove the User Manual (2).

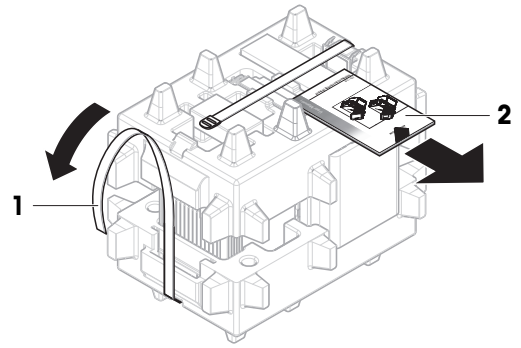

- 3 Remove the upper part of the package and remove the AC/DC adapters (3) and power cables, the pump (4), and the pipetting base with the evaporation trap container (5).

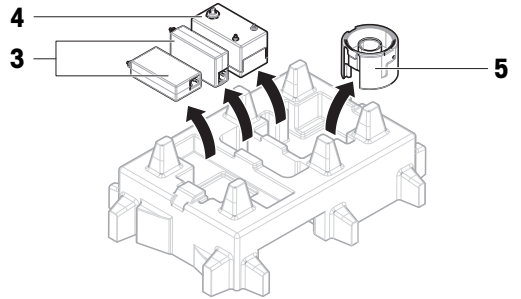

- 4 Carefully remove the terminal (6).

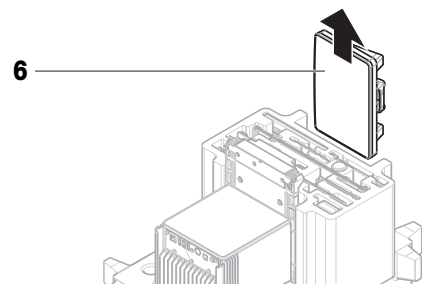

- 5 Carefully remove the package set with the calibration kit and other small items (7).

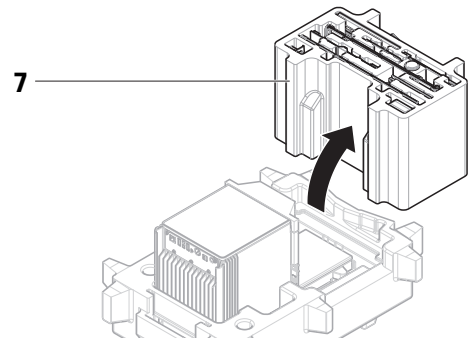

- 6 Carefully remove the weighing unit (8) from the bottom packaging.

- 7 Remove the protective bag.

- 8 Store all parts of the packaging in a safe place for future use.

➔ The weighing unit is ready for assembling.

**See also**

🔗 [Transporting, packing and storing](#) ▶ Page 33

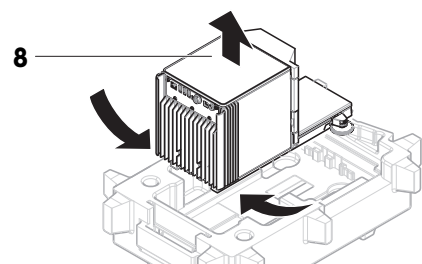

## 4.3 Scope of delivery

### 4.3.1 Balance

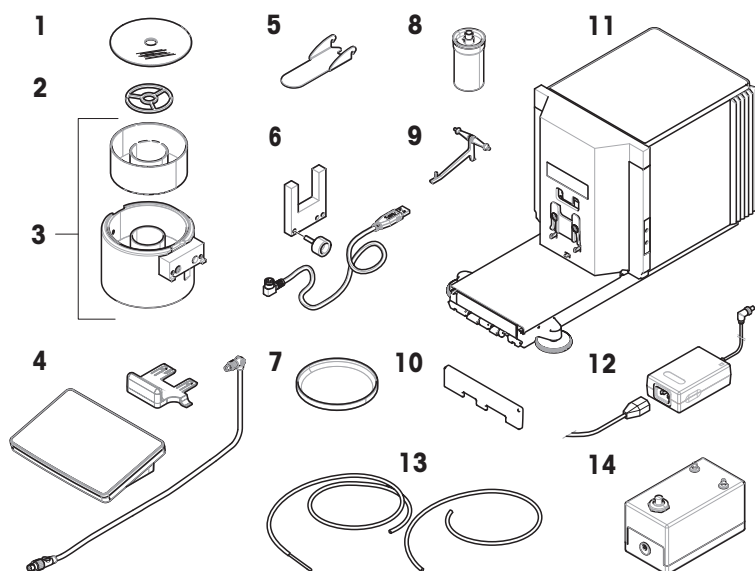

<b>1</b>	Evaporation trap cover	<b>8</b>	Pipetting container and tube
<b>2</b>	Centering ring	<b>9</b>	Support for pipetting container
<b>3</b>	Pipetting base with light barrier spacer and evaporation trap container	<b>10</b>	Front cover
<b>4</b>	Terminal with terminal holder and connection cable	<b>11</b>	Weighing unit
<b>5</b>	Evaporation trap door	<b>12</b>	AC/DC adapter with country-specific power cable, 2 pcs
<b>6</b>	Light barrier, fixing screw and cable	<b>13</b>	Pump tubing, 2 pcs (one tubing with metallic tube)
<b>7</b>	Drip tray	<b>14</b>	Pump

### 4.3.2 Documentation

- User Manual
- Declaration of Conformity
- Production certificate

### 4.3.3 Calibration kit

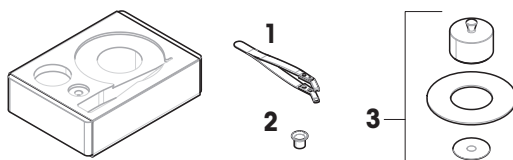

<b>1</b>	Tweezers	<b>3</b>	Weighing pan, large, with cover ring and draft shield
<b>2</b>	Weighing pan, small		

## 4.4 Installation

### 4.4.1 Attaching the terminal



#### NOTICE

##### Damage to the cables due to careless handling

- Do not kink or twist the cables.

- 1 Insert the slides of the display holder (1) into the front of the weighing unit (2).

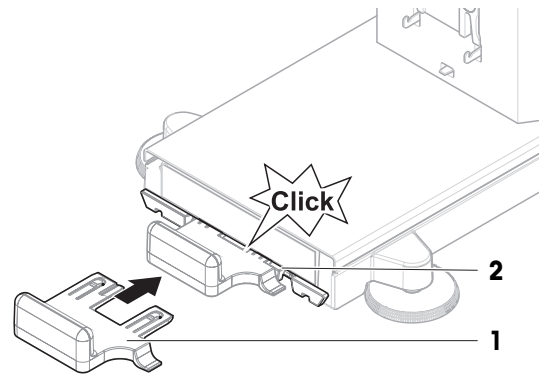

- 2 Connect the terminal cable (3) with the terminal (4). Consider the pin assignment.

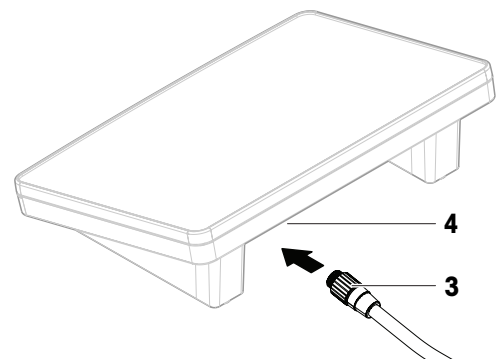

- 3 Place the terminal (5) onto the terminal holder (6).

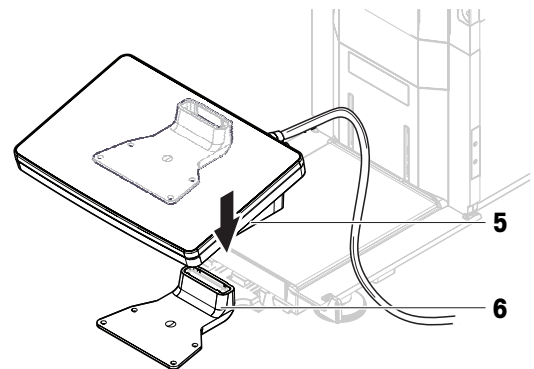

- 4 Carefully tilt the balance to its side.
- 5 Lead the cable (7) through the cable channel (8).
- 6 Carefully put the balance back on its feet.

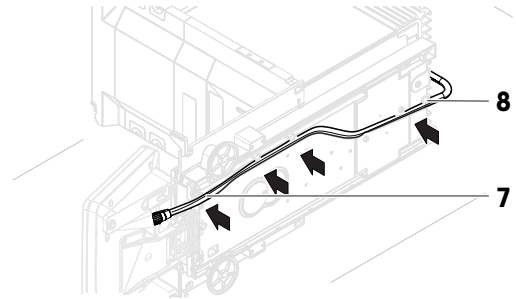

- 7 Insert the terminal cable (9) into the socket of the balance (10). Consider the pin assignment.
- ➔ The terminal is ready.

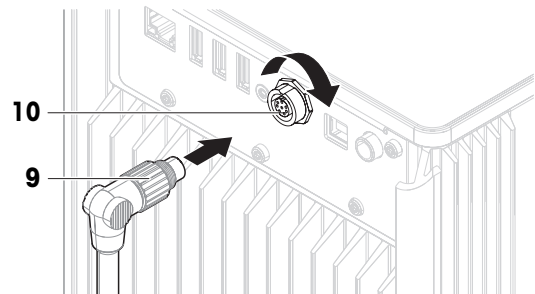

#### 4.4.2 Assembling the balance

- 1 Install the front cover (1).
- 2 Carefully hang the pipetting container support (2) on the hooks (3).
  - ➔ The pipetting container support (2) hangs freely.
- 3 Carefully place the pipetting container (4) onto the pipetting container support (2).
- 4 Center the drip tray (5) underneath the pipetting container (4).

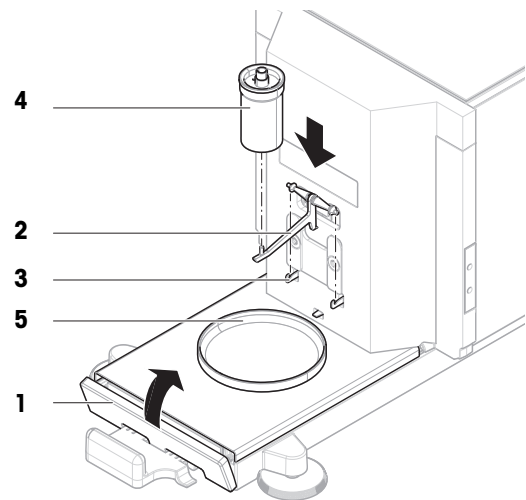

- 5 Carefully slide the pipetting base (6) with the evaporation trap container (7) vertically along the guiding rails and place it onto the drip tray.
  - ➔ The pipetting base centers the drip tray. The pipetting base does not touch the pipetting container (5) or the pipetting container support (3).
- 6 Place the centering ring (8) onto the evaporation trap container (7).
- 7 Carefully place the evaporation trap cover (9) onto the evaporation trap container (7).

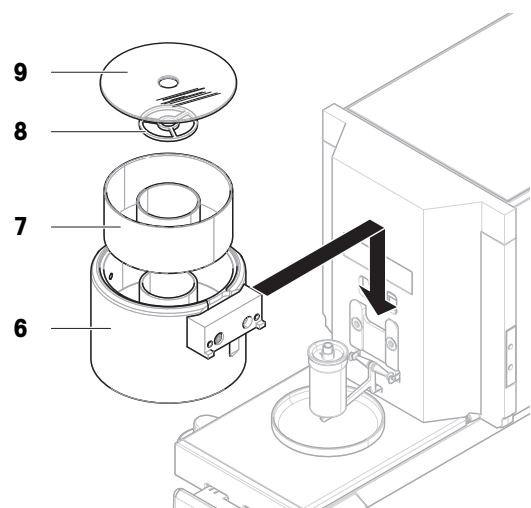



- Slide the evaporation trap door (10) towards the back until it snaps in on the rod (11).

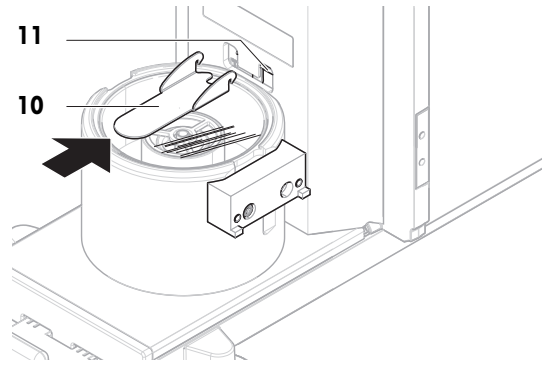

- Connect the light barrier cable (12) to the light barrier (13).
- Install the light barrier (13) on the light barrier spacer (14) using the fixing screw (15).

**Note**

By default, the light barrier and the light barrier spacer are installed on the right side of the pipetting base. Alternatively, these items can be installed on the left side of the pipetting base.

- Guide the light barrier cable (12) along the side of the balance, below the side cover.
  - Connect the light barrier cable (12) to one of the USB-A ports on the back side of the balance.
- ➔ The balance is assembled and ready to be put into operation.

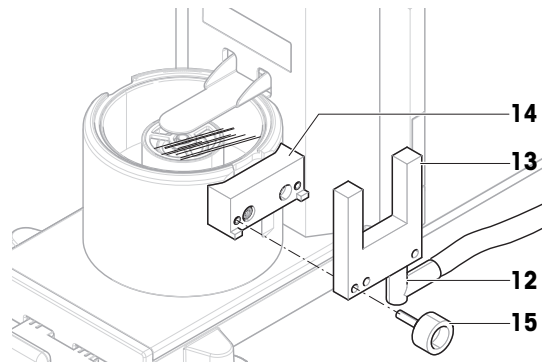

## 4.5 Putting into operation

### 4.5.1 Connecting the balance



#### **WARNING**

##### **Death or serious injury due to electric shock**

Contact with parts that carry a live current can lead to death or injury.

- Only use the METTLER TOLEDO power cable and AC/DC adapter designed for your instrument.
- Connect the power cable to a grounded power outlet.
- Keep all electrical cables and connections away from liquids and moisture.
- Check the cables and the power plug for damage and replace them if damaged.

- Install the cables in such a way that they cannot be damaged or interfere with operation.
  - Insert the plug of the AC/DC adapter (1) into the power socket of the instrument.
  - Secure the plug by firmly tightening the knurled nut.
  - Insert the plug of the power cable into a grounded power outlet that is easily accessible.
- ➔ The balance automatically switches on.
- ➔ The evaporation trap door opens and closes for initialization.

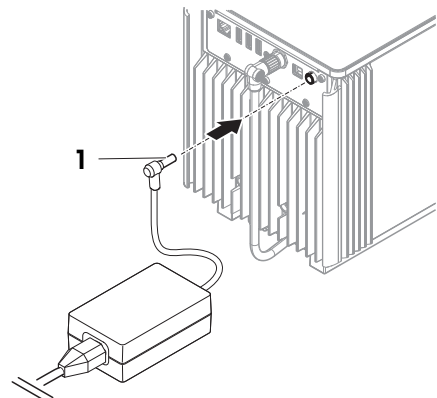

 **Note**

Do not connect the instrument to a power outlet controlled by a switch. After switching on the instrument, it must warm up before giving accurate results.

**See also**

 [General data](#) ▶ Page 120

## 4.5.2 Switching on the balance

When connected to the power supply, the balance automatically switches on.

### **EULA (End User License Agreement)**

When the balance is switched on the first time, the EULA (End User License Agreement) appears on the screen.

- 1 Read the conditions.
- 2 Tap **I accept the terms in the license agreement.** and confirm with **✓ OK.**
  - ➔ The main weighing screen appears.

### **Acclimatization and warm up**

Before the balance gives reliable results, it must:

- acclimatize to the room temperature
- warm up by being connected to the power supply

The acclimatization time and warm-up time for balances are available in "General data".

 **Note**

When the balance is exiting standby, it is ready immediately.

**See also**

 [General data](#) ▶ Page 120

 [Entering / Exiting standby mode](#) ▶ Page 30

## 4.5.3 Logging in

If the user management is activated, you have to log in with your **User name** before performing a weighing. When the balance starts, the login dialog opens automatically.

- 1 Select a user or tap **User name.**
- 2 Tap **Password.**
  - ➔ The input dialog opens.
- 3 Enter your password and tap **✓ OK.**
- 4 Tap **➔ Login.**
  - ➔ The login dialog closes and you are logged in. Your **User name** is shown on the main screen.

The user management can be activated through the balance menu:

**≡ Navigation:** ▶ **Balance menu** > **⚙ Settings** > **📄** > **Balance** > **⚙ General** > **User management**

**See also**

 [Activating the user management](#) ▶ Page 64

 [Users](#) ▶ Page 73

#### 4.5.4 Leveling the balance

Exact horizontal and stable positioning are essential for repeatable and accurate weighing results.

If the message **Balance is out of level** appears:

- 1 Tap ► **Level the balance**.
  - ➔ The **Leveling aid** opens.
- 2 Turn both leveling feet (1) as instructed on the display until the dot is in the center of the level indicator.

The leveling aid can also be accessed through the **Balance menu**:

☰ **Navigation:** ► **Balance menu** > ⌚ **Leveling aid**

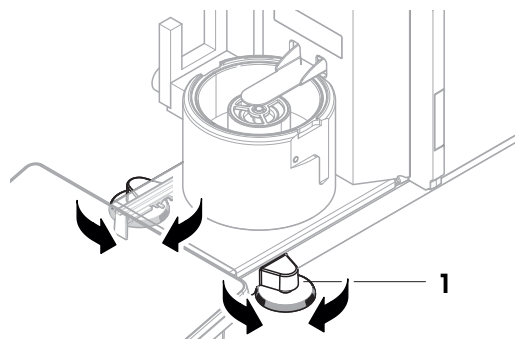

#### 4.5.5 Performing an internal adjustment

☰ **Navigation:** ▼ **Methods** > ⚙️ **Adjustments**

- The adjustment **Strategy** is set to **Internal adjustment**.

- 1 Open the **Methods** section, tap ⚙️ **Adjustments**, select the adjustment, and tap ► **Start**  
- or -  
from the main weighing screen, tap ⋮ **More** and tap **Start adjustment**.
  - ➔ **Internal adjustment** is being executed.
  - ➔ When the adjustment has been completed, an overview of the adjustment results appears.
- 2 Tap 🖨️ **Print** if you want to print the results.
- 3 Tap ✓ **Finish adjustment**.
  - ➔ The balance is ready.

#### 4.5.6 Performing a function check

To perform a function check, use the calibration kit delivered with the balance.

The small weighing pan is used with test weights that have a maximum diameter of 6 mm, for example, a 1 g OIML weight.

The large weighing pan is used with test weights that have a maximum weight of 20 g and a maximum diameter of 35 mm, for example, a 20 g OIML weight.

##### 4.5.6.1 Using the small weighing pan

- The small weighing pan and the evaporation trap door are installed, see [Installing the small weighing pan ► Page 43].
  - The balance is switched on.
- 1 Activate the light barrier (1), or press ⬆️.

- ➔ The evaporation trap door (2) opens.
- 2 Use the tweezers to place the test weight (3) onto the weighing pan (4).
- 3 Activate the light barrier (1), or press  $\downarrow$ .
  - ➔ The evaporation trap door (2) closes.
  - ➔ The weighing result is displayed.
- 4 Tap **+ Add result** if you want to report the weighing result.
  - ➔ The result is added to the **Results list**.

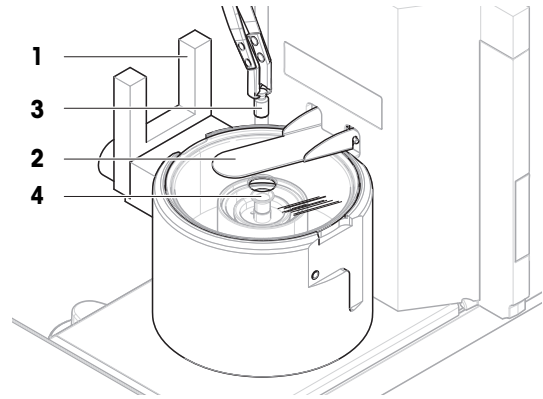

#### 4.5.6.2 Using the large weighing pan

- The large weighing pan, the ring cover, and the draft shield are installed, see [Installing the large weighing pan ▶ Page 43].
- The balance is switched on.
- 1 Remove the draft shield (1) from the cover ring (2).

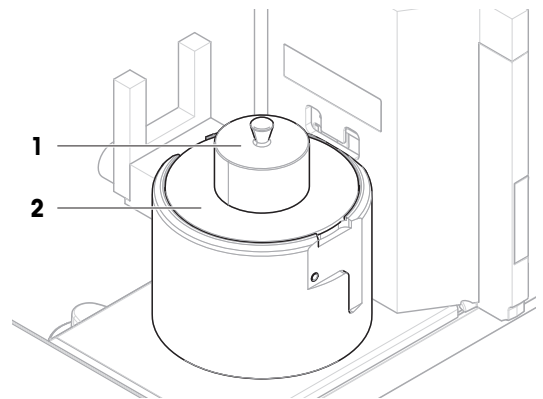

- 2 Use the tweezers to place the test weight (3) onto the weighing pan (4).
- 3 Place the draft shield (1) on the cover ring (2).
  - ➔ The weighing result is displayed.
- 4 Tap **+ Add result** if you want to report the weighing result.
  - ➔ The result is added to the **Results list**.

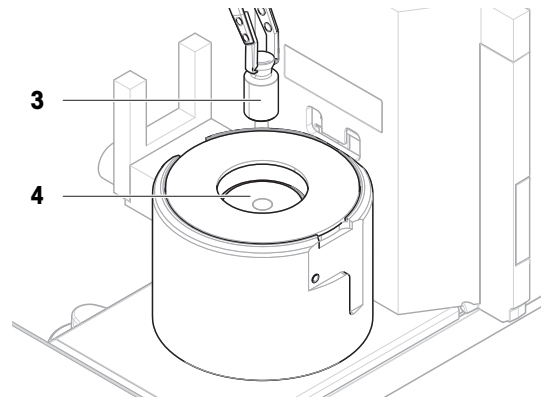

#### 4.5.7 Entering / Exiting standby mode

- 1 To enter standby mode, hold  $\text{⏻}$ .
  - ➔ The display is dark. The balance is still switched on.
- 2 To exit standby mode, press  $\text{⏻}$ .
  - ➔ The display is turned on.

## 4.5.8 Switching off the balance

To completely switch off the balance, it must be disconnected from the power supply. By holding **⏻**, the balance goes only into standby mode.

### **i** Note

When the balance was completely switched off for some time, it must warm up before it can be used.

### See also

[Switching on the balance](#) ▶ Page 28

## 4.6 Performing a pipetting cycle

To calibrate the pipette, distilled water must be used. The volume of the liquid is checked by gravimetric testing.

### 4.6.1 Filling the evaporation trap container

The evaporation trap includes a container that should be filled with water. When the evaporation trap is closed, the humidity inside increases until the air is saturated. This prevents evaporation of the liquid in the pipetting container and ensures accurate weighing results.

- 1 Remove the evaporation trap door (1).
- 2 Carefully remove the evaporation trap cover (2).

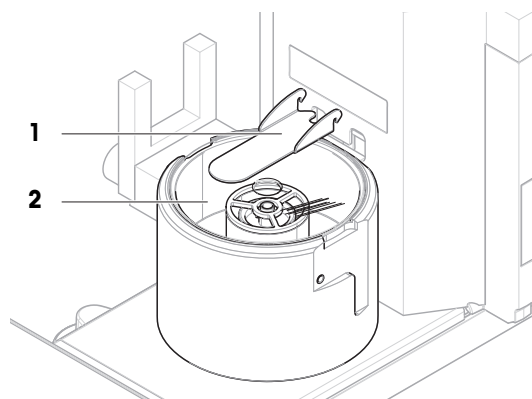

- 3 Fill the evaporation trap container (3) with distilled water.
  - ➔ The evaporation trap container is at least half full (maximum 70 ml).
- 4 Reassemble the balance.
  - ➔ The evaporation trap door (1) is closed.
- 5 Wait at least **120 minutes** to allow the air in the evaporation trap to reach saturation.

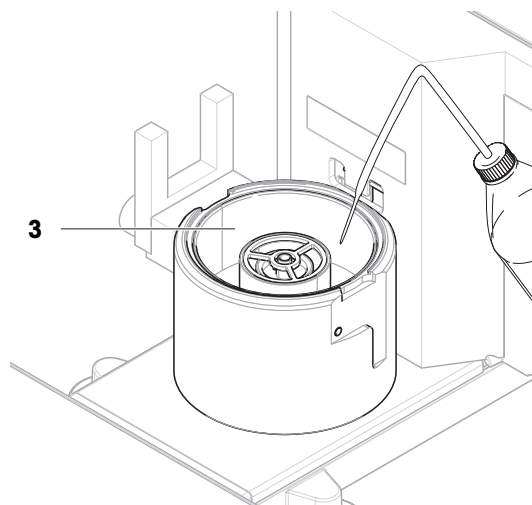

### 4.6.2 Zeroing the balance

- Press **→0←** to zero the balance.
- ➔ The balance is zeroed.

### 4.6.3 Taring the balance

Before a subsequent measurement, the balance must be tared.

- Press **→T←** to tare the balance.
- ➔ The balance is tared. The icon **Net** appears.

### 4.6.4 Performing a pipetting cycle

- The pipette to be calibrated is prepared and set to the target volume.

1 Use the pipette to aspirate the target volume of distilled water.

2 Activate the light barrier (1), or press **↓**.

- ➔ The evaporation trap door (2) opens.

3 Dispense the liquid into the pipetting container (3).

4 Activate the light barrier (1), or press **↓**.

- ➔ The evaporation trap door (2) closes.

- ➔ The weighing result is displayed.

5 Tap **+ Add result** if you want to report the weighing result.

- ➔ The result is added to the **Results list**.

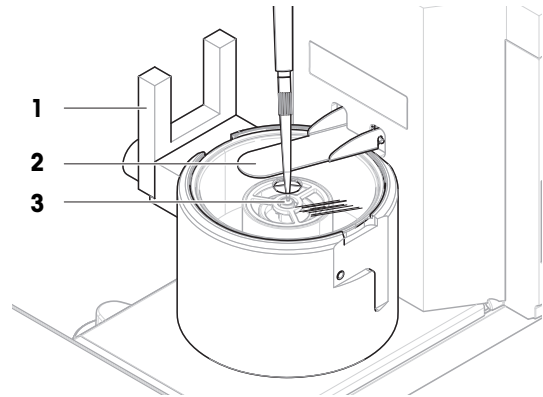

### 4.6.5 Completing the weighing

1 To save the **Results list**, tap **Complete**.

- ➔ The window **Complete task** opens.

2 Select an option to save or print the **Results list**.

- ➔ The respective dialog opens.

3 Follow the instructions from the wizard.

4 Tap **✓ Complete**.

- ➔ The **Results list** is saved/printed and then cleared.

### 4.6.6 Emptying the pipetting container

Regularly empty the pipetting container to prevent an overflow.

#### See also

[Emptying the pipetting container](#) ▶ Page 110

[Cleaning after an overflow](#) ▶ Page 115

## 4.7 Transporting, packing and storing

### 4.7.1 Transporting the balance over short distances

- 1 Disconnect the AC/DC adapter and unplug all interface cables.
- 2 Hold the weighing platform with both hands and carry the balance in horizontal position to the target location. Consider the requirements of the location.

If you want put the balance into operation, proceed as follows:

- 1 Connect in reverse order.
- 2 Give the balance sufficient time to warm up.
- 3 Level the balance.
- 4 Perform an internal adjustment.

#### See also

- 🔗 [Selecting the location ▶ Page 22](#)
- 🔗 [Leveling the balance ▶ Page 29](#)
- 🔗 [Performing an internal adjustment ▶ Page 29](#)

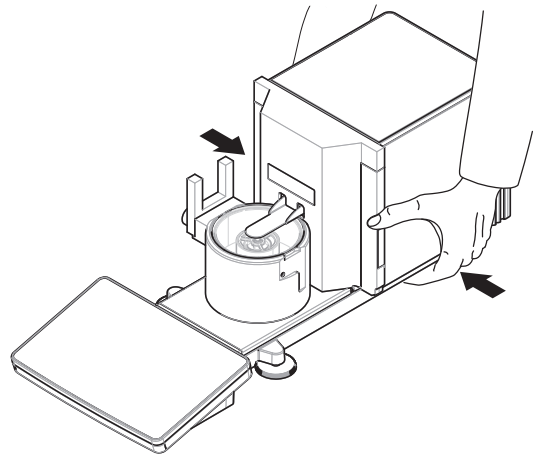

### 4.7.2 Transporting the balance over long distances

METTLER TOLEDO recommends using the original packaging for transportation or shipment of the balance or balance components over long distances. The elements of the original packaging are developed specifically for the balance and its components and ensure maximum protection during transportation.

#### See also

- 🔗 [Unpacking the balance ▶ Page 22](#)

### 4.7.3 Packing and storing

#### Packing the balance

Store all parts of packaging in a safe place. The elements of the original packaging are developed specifically for the balance and its components, and ensures maximum protection during transportation and storage.

#### Storing the balance

Only store the balance under the following conditions:

- Indoor and in the original packaging
- According to the environmental conditions, see "Technical Data"

#### **i** Note

When storing for longer than 6 months, the rechargeable battery may become empty (only date and time get lost).

#### See also

- 🔗 [Technical Data ▶ Page 120](#)

## 5 Operation

### 5.1 Touch screen

#### 5.1.1 Selecting or activating an item

- Tap the item or function to be selected or activated.

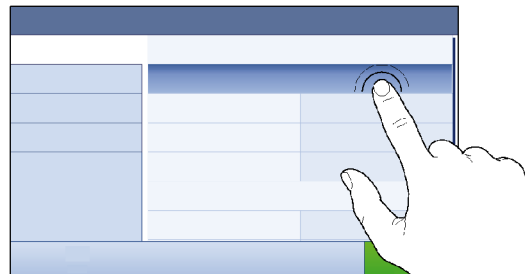

#### 5.1.2 Scrolling

- Move the list up/down.

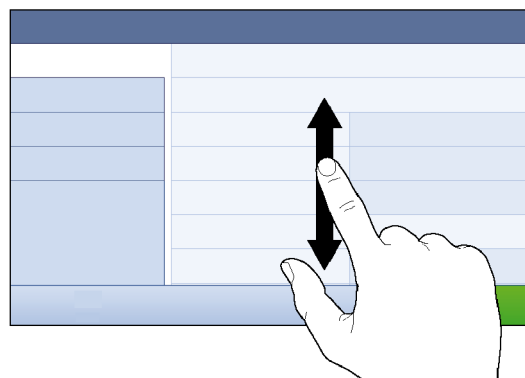

#### 5.1.3 Using the fly-in panels

Three fly-in panels are placed along the sides of the main weighing screen.

- 1 Place the finger on one tab along one side of the screen, e.g., ◀.

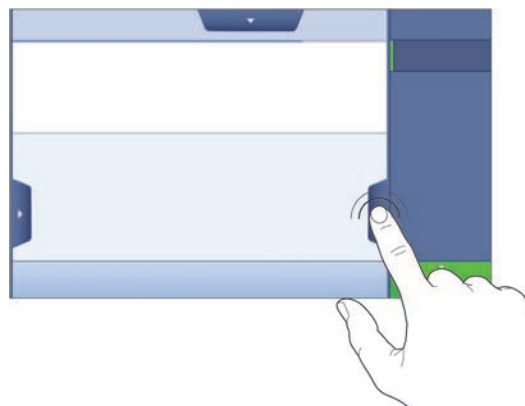



- Keep the finger on the tab and slide it in the direction towards which the arrow is pointing.

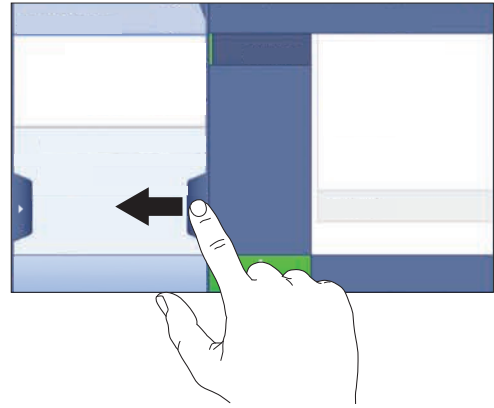

**Note**

The fly-in panels can also be opened or closed by tapping the associated tab.

### 5.1.4 Entering characters and numbers



	Name	Description
1	Input field	Shows the data that has been entered.
2	Backspace	Deletes the character left of the current cursor position. The cursor can be positioned by using the touch screen.
3	Discard	Closes the keyboard dialog.
4	Confirm	Confirms the entered data.
5	Numbers and special characters	Switches into the special character mode.
6	Shift	Switches between lower or upper case letters.
7	Menu section title	Shows the title of the current setting section.

### 5.1.5 Changing the date and time

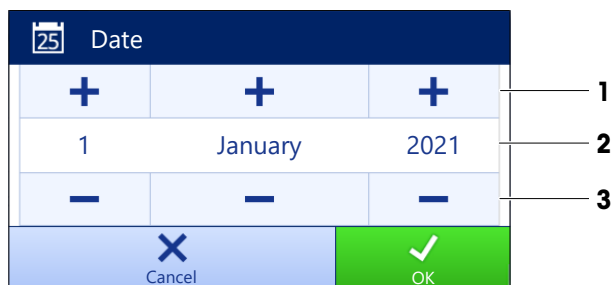

	Name	Explanation
1	Plus button	Increment
2	Display field	Shows the defined time or date.
3	Minus button	Decrement

 **Note**

The format of date and time can be defined in the settings via the options **Date format** and **Time format**.

**See also**

 [Date / Time / Language / Format ▶ Page 80](#)

## 5.2 Methods

A weighing method is an application for carrying out specific weighing tasks. The balance offers the method "General Weighing" with default parameters. You have the possibility to create a maximum of 50 methods and edit the methods. You can use these methods for your weighing task or edit them according to your requirements. Methods can also be deleted or cloned.

To support you while configuring new methods, a configuration wizard leads you through the whole process. The changes performed to a method are recorded in the change history (if activated).

### 5.2.1 Methods overview





The section **Methods list** provides an overview of all methods already created on the balance. In this section, new methods can be defined and existing methods can be edited, cloned or deleted. It is also the starting point for using any method in a weighing procedure.

 **Navigation:**  **Methods** >  **Methods list**

The following method is used for pipette calibration:

-  **General weighing**

The following methods are available, but do not apply to pipette calibration balances:

-  **Simple formulation**
-  **Interval weighing**
-  **Titration**
-  **Density determination**

### 5.2.2 Method "General weighing"

The method **General weighing** offers the basic weighing functions (zeroing, taring, weighing). The method is used for pipette calibration, simple weighing tasks, and routine tests.

The settings of the weighing item, e.g., target weight and tolerances, can be specified for one or multiple weighing items. Two different methods exist:

- **General weighing:**
  - Select this method if you want to work with a single set of parameters.
- **General weighing (itemized):**
  - Select this method if you want to define the parameters for multiple weighing items. A method with multiple weighing items is particularly useful when the weighing task consists of a series of weighings, each with its own individual parameters, such as target weight, tolerances, etc. For further information, see [Using methods with multiple weighing items (itemized) ▶ Page 40].

Methods		
☰ Methods list	⚖️ my general weighing	06/24/2022
🖋️ Manual operations	🔄 my interval weighing	06/24/2022
🕒 Tasks	🗑️ my simple formulation	06/24/2022
🧪 Tests		
🧪 Adjustments		
🗑️ Delete	📄 Clone	✎ Edit
+	+	+
🖨️ Print	▶ Start method	

You have the possibility to start with method factory setting parameter or to create a new method with changed method parameter.

For details about method settings:

#### See also

- 🔗 Settings: method "General weighing" ▶ Page 88
- 🔗 Using methods with multiple weighing items (itemized) ▶ Page 40

### 5.2.2.1 Creating a method "General weighing"

☰ **Navigation:** ▼ **Methods** > ☰ **Methods list**

- 1 Tap **+** **New** in the action bar.
  - ➔ The method wizard opens, starting at **1. Method type**.
- 2 Tap **Method type** and select the method type **General weighing** or **General weighing (itemized)**.
- 3 Tap **→ Next**.
  - ➔ The method wizard opens the section **2. Identification**.
- 4 Define the **Method name** and **Result description** and tap **→ Next**.
  - ➔ The method wizard opens the section **3. Configuration**.
- 5 Select a **Tolerance profile** and tap **→ Next**.
  - ➔ The method wizard opens the section **4. Save**.
  - ➔ If setting up a method with multiple weighing items, the wizard opens the section **4. Weighing items**.
- 6 Select a weighing item from the list and define the **Sample ID**, **Unit**, **Target weight**, **-Tolerance**, and **+Tolerance**.
- 7 To add a weighing item, tap **+ Item** or **📄 Clone**.
- 8 Tap **→ Next**.
  - ➔ The method wizard opens the section **5. Save**.
- 9 Tap **✓ Finish** to save the new method.
  - ➔ The method has been created and appears in the list.

### 5.2.2.2 Performing a "General weighing"

This section describes a **General weighing** example step by step. Depending on the defined settings and weighing objects, the procedure can be different from this example.

- The large weighing pan, the ring cover, and the draft shield are installed, see [Installing the large weighing pan ▶ Page 43].
  - The balance is switched on.
- 1 Open the **Methods** section.
  - 2 Select a method from the **Methods list** or define a new method.

- 3 Tap ► **Start method**.
  - ➔ The main weighing screen appears with the selected method.
- 4 Press →0← to zero the balance.
- 5 Remove the draft shield (1).

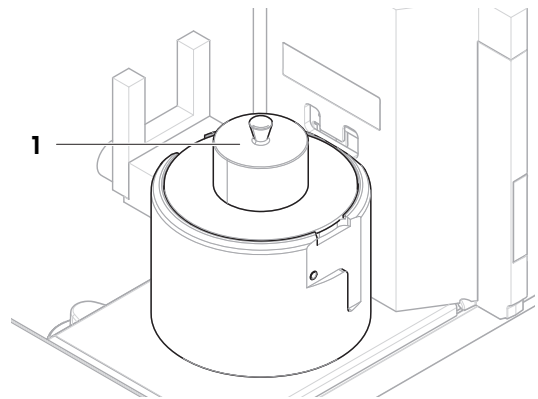

- 6 Place the weighing object (2) on the weighing pan (3).
  - 7 Place the draft shield (1) on the cover ring (4).
    - ➔ The weighing starts with **Capturing weight...**
  - 8 Tap + **Add result**.
    - ➔ The weighing result is saved to the **Results list**.
  - 9 When the weighing process is finished, tap 📄 **Complete** in the action bar.
    - ➔ The window **Complete task** opens. The task-specific information can be printed on a label printer, the **Results list** can be printed manually or automatically (depending on the method settings), and the result can be exported to an external storage device.
- ➔ The task **General weighing** was successfully completed.

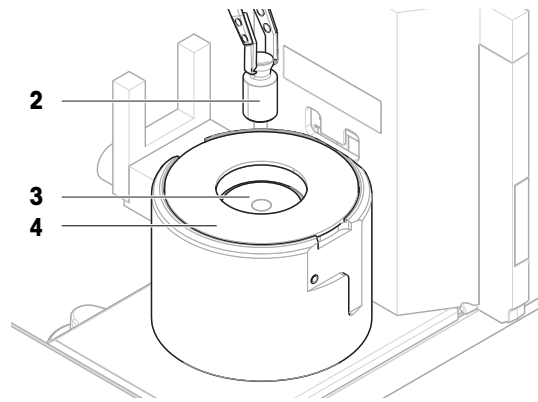

**Note**

It is possible to exclude a weighing result from the **Results list**. Open the **Results list**, select a result to exclude, and tap **Exclude result**.  
 The window **Complete task** always appears after completing the task, even if the results are saved automatically.

### 5.2.3 Editing a method

To clone a method proceed as follows:

- 1 Open the **Methods** section.
- 2 Select the method that you want to edit.
  - ➔ The line color of the selected method becomes blue.
- 3 Tap ✎ **Edit**.

For details about method settings:

**See also**

🔗 Weighing methods settings ► Page 88

## 5.2.4 Cloning a method

To simplify the process to create a method, an existing method can be cloned one or several times. The cloned method will have the same parameter values as the original one. If multiple weighing items exist in the original method, those will be cloned as well.



- 1 Open the **Methods** section.
- 2 Tap the method that you want to clone.
  - ➔ The line color of the selected method becomes blue.
- 3 Tap  **Clone**.
  - ➔ A copy of the selected method appears in the list. The cloned method has the same settings as the original method.

### **Note**

A method can be cloned several times. The name of the cloned method is always based on its original name, to which is appended a number.

## 5.2.5 Deleting a method

Both factory defined methods and user defined methods can be deleted if they are not needed. For this purpose proceed as follows:

- 1 Open the **Methods** section.
- 2 Tap the method that you want to delete.
  - ➔ The line color of the selected method becomes blue.
- 3 Tap  **Delete**.
  - ➔ The message **Delete method and cancel tasks?** appears on the screen.
- 4 Tap  **OK** to delete the selected method.
  - ➔ The system returns to the method list. The method has been deleted and does not appear on the list anymore.

### **Note**





There is always a method activated in the background. This method can not be directly deleted. To delete the method, another method must be started instead. Now the method is not activated anymore and can be deleted.

## 5.2.6 Deleting a task

A method will be held as a task in the task section of the methods menu. It will be paused as a task if any other method is launched without the current method being completed. The method can be paused if it contains one or more weighing results, or has had certain method settings changed.

### **Navigation:** **Methods** > **Tasks**

A task can only be deleted when not in use. The method that is currently used in the background is labeled with the symbol  in the tasks lists. To cancel the task, another task must be activated.

- 1 Select the task to be deleted and tap  **Cancel**.
  - ➔ The dialog  **Cancel task?** opens.
- 2 To delete the task tap  **OK**, to cancel the delete procedure tap  **Cancel**.

## 5.2.7 Using methods with multiple weighing items (itemized)

Working with itemized methods can simplify the workflow, especially when several weighings with different predefined target weights have to be carried out one after the other. Information such as a target weight and tolerances can be defined for each weighing item within a single task. This may save time and increase quality of weighing processes consisting of multiple steps.

Before multiple weighing items can be used in the weighing process, they must be defined. The two ways of creating a weighing method that includes several weighing items are:

- Directly define the multiple weighing items during the method creating process.
- Use the **Results list** of a running method to define a new method with multiple weighing items.

The following methods use multiple weighing items:

- **General weighing (itemized)**

### 5.2.7.1 Creating a new method with multiple weighing items (itemized)

This example describes how to define multiple weighing items for the method **General weighing (itemized)**.

- 1 Open the **Methods** section.
- 2 Tap **+ New** in the action bar.
- 3 Tap **Method type** and select **General weighing (itemized)**.
- 4 Step through the method wizard until step **4. Weighing items**.
  - ➔ The dialog **4. Weighing items** appears.
- 5 Select a weighing item from the list and define the **Sample ID, Unit, Target weight, -Tolerance, and +Tolerance**.
- 6 Tap **→ Next**.
- 7 Tap **✓ Finish**.
  - ➔ The method has been created and appears in the list.

### 5.2.7.2 Creating an itemized method from a completed task

It is possible to create a method with multiple items while performing a method that includes a single item, providing that the method type allows it. This example describes how to create a method **General weighing (itemized)** based on a method **General weighing**.

- 1 Start a method **General weighing**.
- 2 Perform three weighings and add the results to the **Results list** by tapping **+ Add result**.
  - ➔ The results are saved to the **Results list**.
- 3 Tap **⋮ More**.
- 4 Tap **📄 Save as method (itemized)**.
- 5 Define a **Method name**.
- 6 Tap **✓ OK**.
  - ➔ A method **General weighing (itemized)** including three items is created and added to the **Methods list** with the name defined by the user.

### 5.2.7.3 Performing an itemized method

After creating a method with multiple items, it can be started.

- 1 Open the **Methods** section.
- 2 Select an itemized method from the **Methods list**.
- 3 Tap **▶ Start method**.
  - ➔ The main weighing screen opens. The target weight and the tolerance limits defined in the method appear.

## 5.3 Test weights

### 5.3.1 Defining an individual test weight

The user should enter data related to each test weight based on the corresponding certificate. This enables each external test weight to be clearly assigned to a specific certificate. Up to 12 external test weights can be configured. These test weights can be used to carry out external tests and adjustments.

☰ **Navigation:** ▼ **Methods** > 📏 **Tests** > 📊 **Test weights**

**Note**

An external test weight for an external adjustment has to weigh at least 10% of the balance capacity. External test weights under 10% of the balance capacity are not displayed on the balance.

- The dialog **Test weights** is open.
- 1 Tap **+ Test weight**.
- 2 Define the test weight settings and confirm with **✓ Finish**.
- ➔ The test weight is defined and will be available later in the test procedure.

### 5.3.2 Defining a combined test weight

The user can combine test weights to achieve a test weight capacity that is not available as a single standard weight. For example, a weight of 1 g and a weight of 20 g can be combined and used as a test weight of 21 g. Each combined test weight can include two or three test weights. The class of a specific combined weight can only be as good as the worst class of the individual test weights it contains. As for any other test weight, combined test weight can be used to carry out external tests and adjustments.

☰ **Navigation:** ☰ **Methods** > 📏 **Tests** > 📊 **Test weights**

- The dialog **Test weights** is open.
- At least two individual test weights are defined.
- 1 Tap **⚙️ Combined weight**.
- 2 Enter a **Test weight name**.
- 3 Select the **Minimum weight class** for the combined weight.
- 4 Tap **Weights**.
  - ➔ The individual weights of at least **Minimum weight class** are shown.
- 5 Select the weights to include in the combined weight.
- 6 Tap **✓ OK**.
  - ➔ The **Nominal weight** is calculated as the sum of the selected individual weights.
- 7 Tap **✓ Save**.
  - ➔ The combined test weight is defined and will be available later in the test procedure.

## 5.4 Tests

Routine tests can be performed to ensure accurate weighing results according to GWP® or other QM systems. Therefore the tests should be performed in fixed, regular intervals depending on your QM system and the results should be documented in a traceable way.

☰ **Navigation:** ▼ **Methods** > 📏 **Tests**

### 5.4.1 Overview routine tests

METTLER TOLEDO can help you to define the routine tests to be performed based on your process requirements. Please contact your local METTLER TOLEDO representative for additional information.

The calibration kit delivered with the balance is required to perform these tests.

#### 5.4.1.1 Repeatability test

The repeatability test calculates the standard deviation of a series of measurements with a single test weight in order to determine the repeatability of the balance.

Repeatability is a measure of the ability of a balance to supply the same result in repetitive weighings with one and the same load under the same measurement conditions. During the test, a load is placed and measured at the same location on the weighing pan several times. Afterwards, the difference between the measured weight values is calculated. The spread of the measured results leads to the repeatability.

Repeatability is highly affected by the ambient conditions (drafts, temperature fluctuations and vibrations) and also by the skill of the person performing the weighing. Therefore, the series of measurements must be carried out by the same operator, in the same location, under constant ambient conditions and without interruption.

The following test type is available:

- **Repeatab. - 1 TP:** To test the repeatability of the balance at one test point, without tare weight.

#### 5.4.1.2 Sensitivity test

The sensitivity of the balance defines the deviation between the balance reading and the actual load. The sensitivity test allows you to measure the sensitivity using one or two test points.

The following test types are available:

- **Sensitivity - 1 TP:** To test the sensitivity of the balance at one test point, without tare weight.
- **Sensitivity - 2 TP:** To test the sensitivity of the balance at two test points, without tare weight.

### 5.4.2 Creating a new test

Before a test can be performed, the test settings have to be defined. A test wizard is leading you step-by-step through the process.

- 1 Open the **Methods** section.
- 2 Tap **Tests**.
- 3 Tap **+ New**.
  - ➔ The wizard **Create new test** starts.
- 4 Select the test type.
- 5 Work through the process by using the button **→ Next** to go to the next step or the button **← Back** to go back to the previous step.

For details about test settings:

#### See also

[Tests settings](#) ▶ Page 100

### 5.4.3 Preparing the balance for a test

#### 5.4.3.1 Preparing the balance

- 1 Remove the evaporation trap door (1).
- 2 Carefully remove the evaporation trap cover (2).
- 3 Remove the centering ring (3).

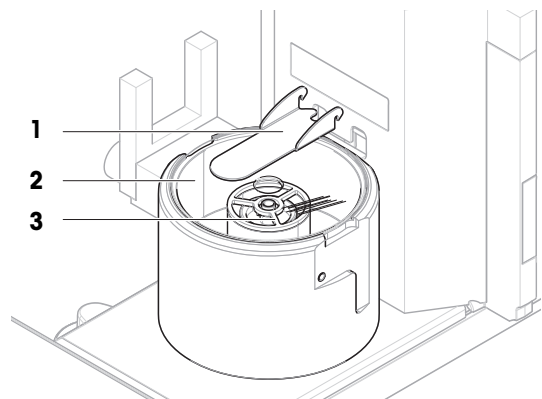



### 5.4.3.2 Installing the small weighing pan

The small weighing pan is used with test weights that have a maximum diameter of 6 mm, for example, a 1 g OIML weight.

- The balance is prepared, see [Preparing the balance ▶ Page 42].
  - The calibration kit is available.
- 1 Place the small weighing pan (1) onto the pipetting container (2).

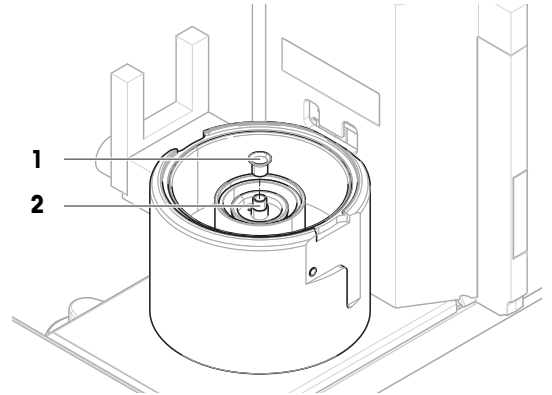

- 2 Carefully place the evaporation trap cover (3) onto the pipetting base (4).

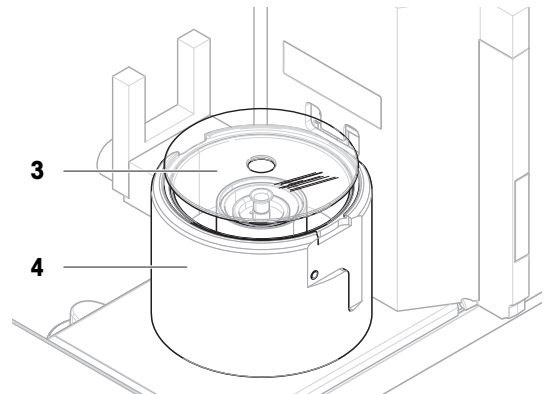

- 3 Slide the evaporation trap door (5) towards the back until it snaps in.

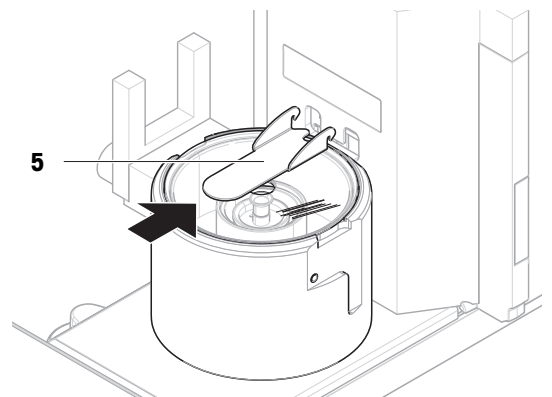

### 5.4.3.3 Installing the large weighing pan

The large weighing pan is used with test weights that have a maximum weight of 20 g and a maximum diameter of 35 mm, for example, a 20 g OIML weight.

- The balance is prepared, see [Preparing the balance ▶ Page 42].
  - The calibration kit is available.
- 1 Place the large weighing pan (1) onto the pipetting container (2).

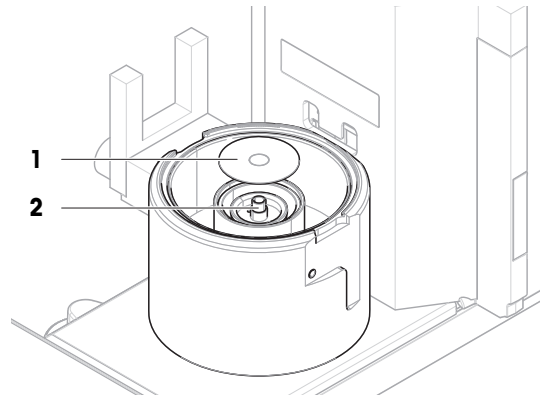

2 Place the cover ring (3) onto the pipetting base (4).

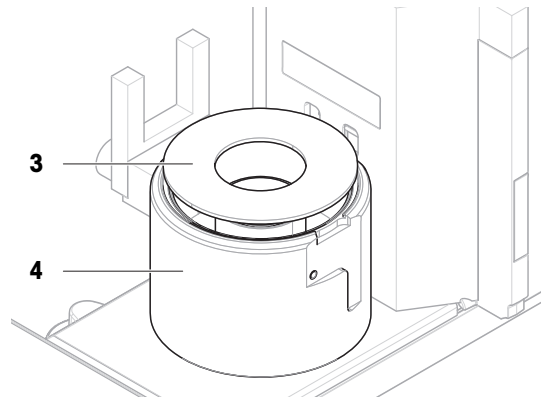

3 Place the draft shield (5) onto the cover ring (3).

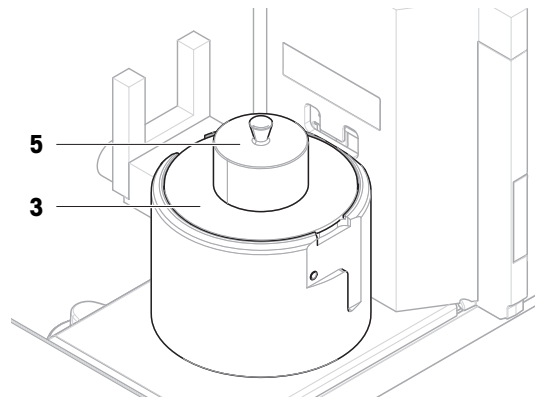

#### 5.4.4 Performing a test



#### NOTICE

#### Incorrect weighing results due to wrong handling of the test weights.

- Only handle test weights with gloves, tweezers, weight forks, or weight handles.

You can perform a repeatability test, or a sensitivity test. Which test you have to perform and when depends on the respective weighing processes. Mettler-Toledo GmbH can help you to define the routine tests to be performed based on your process requirements. Please contact your local METTLER TOLEDO representative for additional information.

Moments when tests could be performed:

- After cleaning
- After a software update
- Daily before putting into operation

- Depending on own SOP

Requirements:

- At least one test weight is defined.
- At least one sensitivity test, or one repeatability test is created.

#### See also

- 🔗 Defining an individual test weight ▶ Page 40
- 🔗 Tests settings ▶ Page 100

### 5.4.4.1 Performing a "Repeatability test"

In this section, the repeatability test for one test point is described. Which test you use depends on the respective test target.

To perform a test, use the calibration kit delivered with the balance.

- The small weighing pan and the evaporation trap door are installed, see [Installing the small weighing pan ▶ Page 43].
  - The balance is switched on.
- 1 Open the **Methods** section.
  - 2 Tap **Tests**.
    - ➔ The test(s) previously defined appear on the list.
  - 3 Select the repeatability test you wish to perform and tap **Start**.
    - ➔ The test sequence starts.
  - 4 Ensure that the weighing pan is empty and clean. Have at hand: the test weight, gloves, and the appropriate tools to handle the test weight.
  - 5 When all requirements are fulfilled tap **✓ OK**.
  - 6 Make sure that the weighing pan is empty and the evaporation trap is closed, then tap **✓OK**.
    - ➔ The balance starts an automatic zeroing.
  - 7 Choose an available test weight
    - or -
    - add a new test weight and tap **✓OK**.
  - 8 Activate the light barrier (1), or press **↓**.
    - ➔ The evaporation trap door (2) opens.
  - 9 Use the tweezers to place the test weight (3) onto the weighing pan (4).
  - 10 Activate the light barrier (1), or press **↓**.
    - ➔ The evaporation trap door (2) closes.
    - ➔ The measurement starts with **Capturing weight...**
    - ➔ The result of the measurement is added to the **Results list**.
  - 11 Activate the light barrier (1), or press **↓**.
    - ➔ The evaporation trap door (2) opens.
  - 12 Remove the test weight carefully and tap **✓ OK**.
    - ➔ The balance starts an automatic zeroing.
    - ➔ Depending on the specified **Number of repetitions** you have to repeat the last four steps a certain number of times.
  - 13 When the test procedure is finished, tap **Finish**.
    - ➔ The result dialog opens.
  - 14 To print the results tap **Print**, to finish the test tap **✓ Finish**.

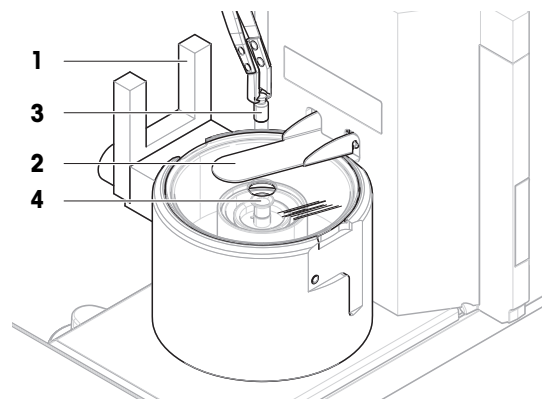

## Test result

If the test failed, see "Troubleshooting", search the error, remedy it and test again. If the test fails again, contact a METTLER TOLEDO representative.

## See also

[Settings: Repeatability test](#) ▶ Page 100

[Troubleshooting](#) ▶ Page 117

### 5.4.4.2 Performing a "Sensitivity test"

In this section, the sensitivity test for one test point is described. Which test you use depends on the respective test target.

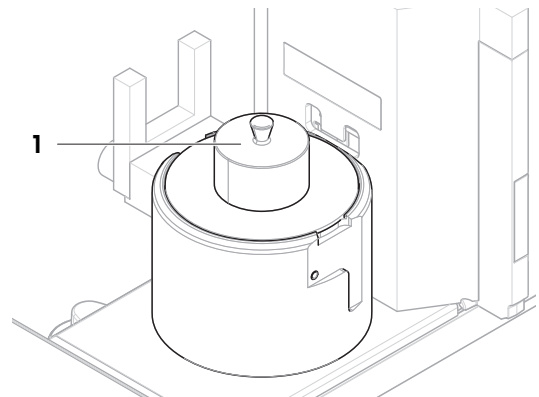

To perform a test, use the calibration kit delivered with the balance.

- The large weighing pan, the ring cover, and the draft shield are installed, see [Installing the large weighing pan ▶ Page 43].
  - The balance is switched on.
- 1 Open the **Methods** section.
  - 2 Tap **Tests**.
    - ➔ The test(s) previously defined appear on the list.
  - 3 Select the sensitivity test you wish to perform and tap **Start**.
    - ➔ The test sequence starts.
  - 4 Ensure that the weighing pan is empty and clean. Have at hand: the test weight, gloves, and the appropriate tools to handle the test weight.
  - 5 When all requirements are fulfilled tap **✓ OK**.
  - 6 Make sure that the weighing pan is empty and the draft shield is installed, then tap **✓OK**.
    - ➔ The balance starts an automatic zeroing.
  - 7 Choose an available test weight
    - or -
    - add a new test weight and tap **✓OK**.
  - 8 Remove the draft shield (1).

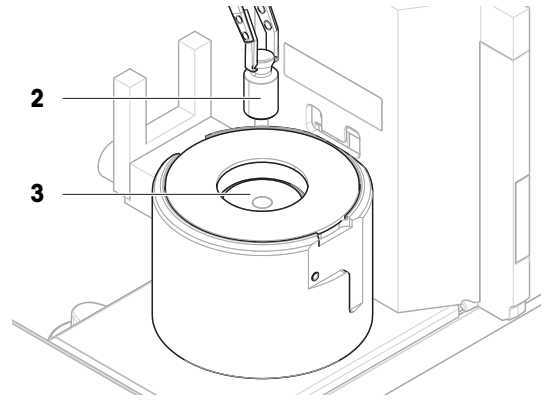

- Use the tweezers to place the test weight (2) onto the weighing pan (3).



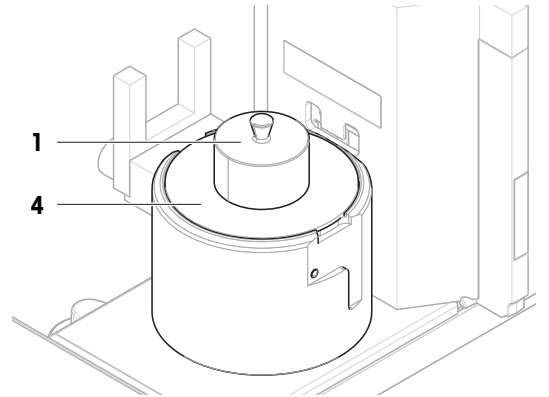

- Place the draft shield (1) onto the cover ring (4).
  - ➔ The measurement starts with **Capturing weight...**
  - ➔ The result of the measurement is added to the **Results list**.
- When the test procedure is finished, tap  **Finish**.
  - ➔ The result dialog opens.
- To print the results tap  **Print**, to finish the test tap  **Finish**.



### Test result

If the test failed, see "Troubleshooting", search the error, remedy it and test again. If the test fails again, contact a METTLER TOLEDO representative.

### See also

-  Settings: Sensitivity test ▶ Page 103
-  Troubleshooting ▶ Page 117

## 5.4.5 Editing a test



A test can only be edited when it is not running.

☰ **Navigation:** ▼ **Methods** >  **Tests**





- Select the test to be edited from the list and tap  **Edit**.
  - ➔ The test settings open.
- Edit the test settings.

## 5.4.6 Printing test results

You can print a test manually, whether the parameter **Automatic print** in the test settings is activated or deactivated. For this purpose proceed as follows:

- Open the **Methods** section.
- Tap  **Tests**.
  - ➔ The test list opens.
- Select the test to print and tap  **Print all**.
  - ➔ The test is printed.

## 5.4.7 Deleting a test

- 1 Open the **Methods** section.
- 2 Tap  **Tests**.
  - ➔ The test list opens.
- 3 Select the test to delete.
- 4 Tap  **Delete**.
  - ➔ The section **Delete routine test** opens. The message **Do you really want to delete the selected routine test?** appears.
- 5 Tap  **Yes** to delete the test. Tap  **No** to cancel the deleting process.
  - ➔ After deleting the test, the system returns to the test list. The test has been deleted and does not appear on the list anymore.

Running tests are labeled with the symbol  and cannot be deleted. To delete a test, it must be finished or another test must be activated. To delete a test, proceed as follows:

## 5.4.8 Consulting the test history

≡ **Navigation:** ▶ **Balance menu** >  **History** >  **Tests**

- Select a test.
- ➔ The test history opens. Specific data are displayed for each test, such as the date and time, type of test, temperature, level state, test weight ID, and weight deviation.

### See also

 [History](#) ▶ Page 71



## 5.5 Adjustments

This section describes how internal and external adjustments can be defined and performed. Which type of adjustment is performed depends on the defined adjustment **Strategy**.

≡ **Navigation:** ▼ **Methods** >  **Adjustments**

### 5.5.1 Internal adjustment

#### 5.5.1.1 Editing an "Internal adjustment"



- 1 Open the **Methods** section.
- 2 Tap  **Adjustments**.
- 3 Tap  **Edit**.
- 4 Set the **Strategy** to **Internal adjustment**.
- 5 Define the adjustment parameters.
- 6 Tap  **Save**.
  - ➔ Your internal adjustment has been edited.



For details about adjustment settings:

### See also

 [Adjustments settings](#) ▶ Page 106







#### 5.5.1.2 Performing an "Internal adjustment"

- The adjustment **Strategy** is set to **Internal adjustment**.
- 1 Open the **Methods** section, tap  **Adjustments**, select the adjustment, and tap ▶ **Start**
    - or -
    - from the main weighing screen, tap  **More** and tap **Start adjustment**.

- ➔ **Internal adjustment** is being executed.
  - ➔ When the adjustment has been completed, an overview of the adjustment results appears.
- 2 Tap  **Print** if you want to print the results.
  - 3 Tap  **Finish adjustment**.
- ➔ The balance is ready.

## 5.5.2 External adjustment

### 5.5.2.1 Editing an "External adjustment"

- 1 Open the **Methods** section.
- 2 Tap  **Adjustments**.
- 3 Tap  **Edit**.
- 4 Set the **Strategy** to **External adjustment**.
- 5 Tap  **Test weights - Edit test weight**.
  - ➔ The dialog **Test weights - Edit test weight** opens.
- 6 Select a test weight from the list and tap  **OK**  
- or -  
tap  **Test weight** to define a new test weight.
- 7 Define the test weight settings and confirm with  **OK**.
- 8 Tap  **Save**.
  - ➔ Your external adjustment has been edited.

For details about adjustment settings:







#### See also

 Adjustments settings ▶ Page 106

### 5.5.2.2 Performing an "External adjustment"

After the external weights have been defined, the function **External adjustment** can be performed.

To perform an adjustment, use the calibration kit delivered with the balance. Choose the small or the large weighing pan, depending on the size of the external weights. The example describes the procedure with the small weighing pan.

- The small weighing pan and the evaporation trap door are installed, see [Installing the small weighing pan ▶ Page 43].
  - The balance is switched on.
  - The adjustment **Strategy** is set to **External adjustment**.
- 1 Open the **Methods** section, tap  **Adjustments**, select the adjustment, and tap  **Start**  
- or -  
from the main weighing screen, tap  **More** and tap **Start adjustment**.
    - ➔ The adjustment process starts.
  - 2 Ensure that the weighing pan is empty and clean. Have at hand: the test weight, gloves, and the appropriate tools to handle the test weight.
  - 3 When all requirements are fulfilled tap  **OK**.
  - 4 Make sure that the weighing pan is empty and the evaporation trap is closed, then tap  **OK**.
  - 5 Choose an available test weight  
- or -  
add a new test weight and tap  **OK**.

- 6 Activate the light barrier (1), or press  $\updownarrow$ .  
 ➔ The evaporation trap door (2) opens.
- 7 Use the tweezers to place the test weight (3) onto the weighing pan (4).
- 8 Activate the light barrier (1), or press  $\updownarrow$ .  
 ➔ The evaporation trap door (2) closes and the adjustment starts.
- 9 Activate the light barrier (1), or press  $\updownarrow$ .  
 ➔ The evaporation trap door (2) opens.
- 10 Remove the test weight carefully and tap  $\checkmark$  **OK**.  
 ➔ The adjustment is finishing and the adjustment results appear.
- 11 To print the results tap  **Print**, to finish the adjustment tap  $\checkmark$  **Finish**.

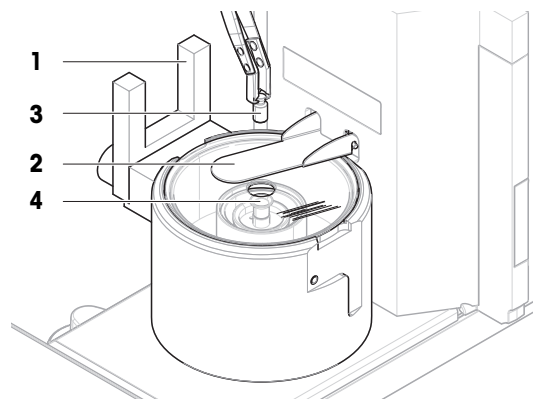

**See also**

 Defining an individual test weight ▶ Page 40

### 5.5.3 Consulting the adjustment history

 **Navigation:** ▶ **Balance menu** >  **History** >  **Adjustments**

- Select an adjustment.
- ➔ The adjustment history opens. Specific data are displayed for each adjustment such as the date and time, type of adjustment, temperature, level state, adjustment trigger, and correction.

**See also**

 History ▶ Page 71

## 5.6 Peripheral devices

### 5.6.1 Printer

Printers can help document your processes and results. Two types of printers can be connected to the balance:

- strip printer: to print on strip paper, for example, for the documentation of weighing result
- label printer: to print on label stickers, for example, for the identification of samples

Each weighing method offers the possibility to trigger the printing process manually on a label or on strip paper when completing a task. The settings of the method can also be edited such that the results are automatically printed when a result is added to the result list or when the task is complete, for example. When using a label printer, the template of the printed label is defined individually for each method.

The following sections show typical use cases of installing and using a printer with the balance. They cover two combinations of settings amongst: manual and automatic printing, strip and label printing, task results and weighing item results printing, as well as USB and Bluetooth connections. Other combinations of settings can be achieved similarly.



#### NOTICE

##### Damage to the device due to inappropriate use

- Consult the User Manual of the device before using it.

#### 5.6.1.1 Printing results manually on a strip printer via USB

This example describes how to install a strip printer using a USB cable. For this example, the method does not include automatic printing, but the results are printed manually when the task is completed.



## Installing and configuring the printer

- The printer is connected to the power outlet and switched on.
  - The USB cable is connected to the printer.
  - The main weighing screen is shown on the balance terminal.
- 1 Connect the USB cable to one of the USB-A ports of the balance.
    - ➔ The balance detects the USB device automatically. The dialog **Add device** appears, informing the user that the system has found a specific device.
  - 2 Set a name for the USB device, then tap → **Next**.
  - 3 Tap ✓ **Finish**.
    - ➔ The USB device is connected and saved to the system.
    - ➔ The settings of the device are displayed.
  - 4 Tap **Printer settings**.
  - 5 Tap **Printer category** and select **Strip printer**.
  - 6 Tap ✓ **Save**.

### **Note**

Some printers can print both on labels or on strip paper. In those cases, the printer type must be specified in the settings of the printer. If the printer can only print on labels or can only print on strip paper, the printer type is set automatically.

### **Note**

A label printer and a strip printer can be connected simultaneously to the balance. However, only one printer of a specific type can be active at any given time. When connecting a new printer of the same type, the printer of the same type that was previously active is deactivated automatically. After connecting a new printer, verify the status of all other printers.

### **Note**

If the USB cable is disconnected and reconnected, the connection will be detected automatically. The printer does not need to be installed again.

## Printing a test page

After installing and configuring a printer, a test page can be printed.

≡ **Navigation:** ▶ **Balance menu** > ⚙ **Settings** > 🖨 **Devices / Printers**

- A printer is connected to the balance.
- 1 Navigate to the section 🖨 **Devices / Printers**.
  - 2 Select the printer in the list of devices.
  - 3 Tap ✓ 🖨 **Print test page** in the action bar.

## Printing the results

≡ **Navigation:** ▼ **Methods** > ☰ **Methods list**

- A strip printer is connected to the balance.
- 1 Select a method from the **Methods list**.
  - 2 Tap ▶ **Start method**.
  - 3 Perform the necessary actions to weigh your sample(s).
  - 4 Tap 📄 **Complete** to open the export options.
    - ➔ The dialog **Complete task** appears.
  - 5 Tap **Print results manually** to print the results on the strip printer.

## See also

 [Devices / Printers ▶ Page 85](#)

### 5.6.1.2 Printing results automatically on a label printer via Bluetooth

This example describes how to install a label printer using a Bluetooth adapter. For this example, the method is set such that a label is printed automatically every time the user taps **Add result**.



For more information about how to install your Bluetooth adapter, consult the Installation Instructions provided with it.

#### Installing and configuring the printer

Navigation: ► Balance menu > ⚙ Settings > 📶 Interfaces > 📶 Bluetooth

Navigation: ► Balance menu > ⚙ Settings > 🖨 Devices / Printers

- The printer is connected to the power outlet and switched on.
- A Bluetooth RS adapter (to connect to the printer) and a Bluetooth USB adapter (to connect to the balance) are available.
- The switch on the Bluetooth RS adapter is in the position DCE.
- You have identified the MAC address (unique device address) on the Bluetooth RS adapter.
- The main weighing screen is shown on the balance terminal.

1 Connect the Bluetooth USB adapter (1) to one of the USB-A ports (2) of the balance.

2 Connect the Bluetooth RS adaptor (3) to the printer (4).

➔ The lights on the Bluetooth RS adaptor start blinking.

3 Navigate to the section 📶 Bluetooth.

4 Set **Activation** to **Active**.

5 Tap ✓ **Save**.

6 Navigate to the section 🖨 Devices / Printers.

7 Tap + **Add device**.

➔ The dialog **Add device** opens.

8 Select **Bluetooth connection** and tap → **Next**.

➔ The message **Searching for devices...** appears.

➔ The MAC addresses of all the available Bluetooth devices appear.

9 Select the MAC address of the Bluetooth RS adapter from the list and tap → **Next**.

10 Check that the **PIN Code** is correct: [Mettler-Toledo](#).

11 Tap → **Next** to confirm the Bluetooth connection.

➔ The balance is pairing the Bluetooth USB adapter from the balance with the Bluetooth RS adapter from the printer.

➔ The system informs the user that it has found the device.

12 Set a name for the USB device, then tap → **Next**.

13 Tap ✓ **Finish**.

➔ The USB device is connected and saved to the system.

➔ The settings of the device are displayed.

14 Tap **Printer settings**.

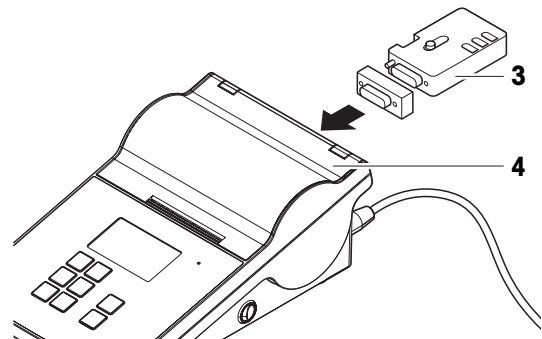
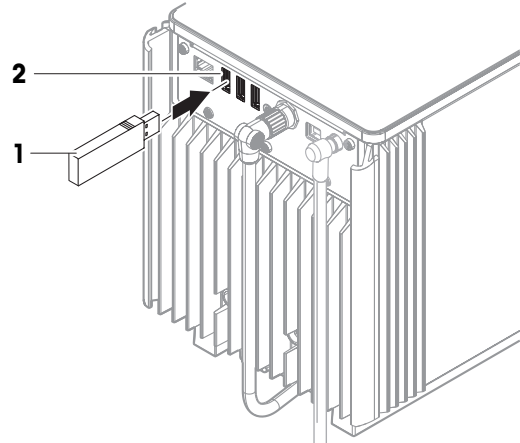

15 Tap **Printer category** and select **Label printer**.

16 Tap **✓ Save**.

**Note**

When setting up the Bluetooth connection, the balance pairs with the Bluetooth RS adaptor, not with the printer that is attached to it. When the user connects the same Bluetooth RS adaptor to another printer, the user must remove the configured printer from the list of devices and add the new printer.

**Note**

Some printers can print both on labels or on strip paper. In those cases, the printer type must be specified in the settings of the printer. If the printer can only print on labels or can only print on strip paper, the printer type is set automatically.

**Note**

A label printer and a strip printer can be connected simultaneously to the balance. However, only one printer of a specific type can be active at any given time. When connecting a new printer of the same type, the printer of the same type that was previously active is deactivated automatically. After connecting a new printer, verify the status of all other printers.

**Note**

If the USB adaptor is removed from the balance and plugged in again, the Bluetooth connection will be detected automatically. This may take up to 30 seconds.

### Printing a test page

After installing and configuring a printer, a test page can be printed.

**Navigation:** ► **Balance menu** > **Settings** > **Devices / Printers**

- A printer is connected to the balance.

  - 1 Navigate to the section **Devices / Printers**.
  - 2 Select the printer in the list of devices.
  - 3 Tap **Print test page** in the action bar.

### Editing the method settings

**Navigation:** ▼ **Methods** > **Methods list**

- 1 Select a method from the **Methods list**.
- 2 Tap **Edit**.
- 3 Tap **Print / Export**.
- 4 Tap **Label printout for weighing item**.
- 5 Set **Automatic label printout for weighing item** to **Active**.
- 6 Select the desired template from the list: **Used template**.
- 7 Tap **Field settings**.
- 8 Customize the content of each field.
- 9 Tap **OK**.
- 10 Tap **Save**.

### Printing the results

**Navigation:** ▼ **Methods** > **Methods list**

- A label printer is connected to the balance.
- A method exists with the desired template for the printed label.

  - 1 Select the method from the **Methods list**.
  - 2 Tap **Start method**.
  - 3 Perform the necessary actions to weigh your sample.

4 Tap **+** **Add result**.

➔ The label for this weighing item is automatically printed on the label printer.

#### See also

 Bluetooth ▶ Page 84

 Devices / Printers ▶ Page 85

## 5.6.2 RFID reader

Smart Tags are RFID stickers that you can attach to the bottom of sample vessels. They are used to store information about the sample. They are typically used with the method type **Titration**. The content of the Smart Tags can be accessed and edited using an RFID reader, for example, an EasyScan USB or a SmartScan.



### NOTICE

#### Damage to the device due to inappropriate use

– Consult the User Manual of the device before using it.

#### See also

 Devices / Printers ▶ Page 85

### 5.6.2.1 Reading data from an RFID Smart Tag using an EasyScan USB



This example describes how to use an EasyScan USB to read data from a Smart Tag.

#### Installing the EasyScan USB

- An EasyScan USB is available.
- A USB-A to USB-B cable is available.
- The main weighing screen is shown on the balance terminal.
  - 1 Connect the USB cable to a USB-A port on the balance.
  - 2 Connect the USB cable to the USB-B port of the RFID reader.
    - ➔ The balance detects the USB device automatically. The dialog **Add device** appears, informing the user that the system has found a specific device.
  - 3 Set a name for the USB device, then tap **→ Next**.
  - 4 Tap **✓ Finish**.
    - ➔ The USB device is connected and saved to the system.
    - ➔ The settings of the device are displayed.
  - 5 Tap **✓ Save**.

#### Testing the RFID reader

≡ **Navigation:** ▶ **Balance menu** >  **Settings** >  **Devices / Printers**

- An RFID reader is installed on the balance.
- A Smart Tag RFID tag is available.
  - 1 Navigate to the section  **Devices / Printers**.
  - 2 Select the device from the list of devices and printers.
  - 3 Tap  **Test device**.

- ➔ The dialog **Test RFID device** opens.
- 4 Place an RFID tag on the RFID reader.
    - ➔ If the RFID reader works correctly, the message **RFID tag successfully detected.** is shown.
    - ➔ The RFID reader is working properly.

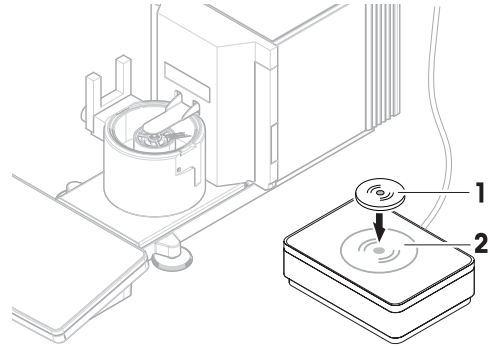

### Reading data from a Smart Tag

☰ **Navigation:** ▶ **Balance menu** > **Maintenance** > **Format RFID**

- An RFID reader is installed on the balance.
  - A Smart Tag RFID tag is available.
- 1 Navigate to the section **Format RFID**.
  - 2 Tap **Format RFID**.
    - ➔ The dialog **Format RFID tag** opens.
  - 3 Place the RFID tag on the RFID reader.
    - ➔ The wizard asks **Do you want to format the RFID tag and delete all data?**
    - ➔ In the dialog, you can read all the stored data.
  - 4 To format the RFID tag, tap → **Format**. To close the dialog, tap ✕ **Cancel**.

#### 5.6.2.2 Formatting an RFID Smart Tag using an EasyScan

This example describes how to use a SmartScan to format a Smart Tag, that is, delete all data. This example describes how to use an EasyScan to format a Smart Tag, that is, delete all data.

### Formatting a Smart Tag

☰ **Navigation:** ▶ **Balance menu** > **Maintenance** > **Format RFID**

- An RFID reader is installed on the balance.
  - A Smart Tag RFID tag is available.
- 1 Navigate to the section **Format RFID**.
  - 2 Tap **Format RFID**.
    - ➔ The dialog **Format RFID tag** opens.
  - 3 Place the RFID tag on the RFID reader.
    - ➔ The wizard asks **Do you want to format the RFID tag and delete all data?**
  - 4 To format the RFID tag, tap → **Format**.
    - ➔ The RFID tag is formatted.

#### 5.6.3 Foot switch and ErgoSens

The foot switch and the ErgoSens are optional accessories that allow you to perform operations on your balance without having to use the terminal. The following section shows an example of an operation that can be performed with a foot switch or an ErgoSens.



### NOTICE

#### Damage to the device due to inappropriate use

- Consult the User Manual of the device before using it.

### 5.6.3.1 Taring the balance with an ErgoSens

This example explains how to install a USB ErgoSens and configure it to tare the balance.

#### Installing and configuring the ErgoSens

- An ErgoSens is available.
- The main weighing screen is shown on the balance terminal.
- 1 Connect the USB cable to one of the USB-A ports of the balance.
  - ➔ The balance detects the USB device automatically. The dialog **Add device** appears, informing the user that the system has found a specific device.
- 2 Set a name for the USB device, then tap → **Next**.
- 3 Tap ✓ **Finish**.
  - ➔ The USB device is connected and saved to the system.
  - ➔ The settings of the device are displayed.
- 4 Tap **Function** and select **Tare**.
- 5 Tap ✓ **Save**.
  - ➔ The ErgoSens is ready to use to tare the balance.

#### See also

 [Devices / Printers](#) ▶ Page 85



### 5.6.4 Editing the settings of a device

≡ **Navigation:** ▶ **Balance menu** >  **Settings** >  **Devices / Printers**

- 1 Navigate to the section  **Devices / Printers**.
  - ➔ A list of devices appears, showing the connection status and the connection type of each device.
- 2 Select the device from the list of devices and printers.
  - ➔ The details of the device are shown.
- 3 To change the name of the device, tap **Name**, enter the name and tap ✓.
- 4 Some devices have additional editable settings. Tap on those settings to edit them.
- 5 Save the settings.

### 5.6.5 Deleting a device

≡ **Navigation:** ▶ **Balance menu** >  **Settings** >  **Devices / Printers**

- 1 Navigate to the section  **Devices / Printers**.
  - ➔ A list of devices appears, showing the connection status and the connection type of each device.
- 2 Select the device from the list of devices and printers.
- 3 Tap  **Delete device**.
  - ➔ A message appears, asking you to confirm that you want to delete the device.
- 4 To delete, tap ✓ **OK**. To cancel the delete dialog, tap ✕ **Cancel**.
  - ➔ The device is deleted.

## 5.7 Remote control via services

### 5.7.1 LabX service

To enable communication between LabX and instruments, the appropriate settings on the instruments must correspond with the settings in LabX. LabX synchronizes the date and time on the instruments with the LabX Server each time a connection is made and each time a task is started. When an instrument is connected, the user interface language on the connected instrument is changed to the language currently installed on the LabX installation.



To install LabX on your computer and for more information about LabX, consult the LabX Reference Manual (RM).

#### **Note**

Once the connection between LabX and the balance is established, the balance terminal is controlled by LabX. It is always possible to switch to manual mode directly on the terminal.

#### **See also**

[LabX / Services](#) ▶ Page 86

#### 5.7.1.1 Using LabX via a USB connection

To establish this connection, the USB driver must be installed on your computer. The driver is available online:

▶ [www.mt.com/labweighing-software-download](http://www.mt.com/labweighing-software-download)

##### **Connecting the balance to the computer**

- A USB-A to USB-B cable is available.

  - 1 Connect the USB cable to the USB-B port of the balance.
  - 2 Connect the USB cable to a USB-A port on the computer.

##### **Configuring the service on the balance**

≡ **Navigation:** ▶ **Balance menu** > ⚙️ **Settings** > 📡 **LabX / Services**

- 1 Navigate to the section 📡 **LabX / Services**.
- 2 Set **LabX service** to **USB**.
- 3 Tap ✓ **Save**.

#### 5.7.1.2 Using LabX via an Ethernet connection

##### **Connecting the balance to the network**

≡ **Navigation:** ▶ **Balance menu** > ⚙️ **Settings** > 📡 **Interfaces**

- An Ethernet cable is available.

  - 1 Connect the Ethernet cable to the Ethernet port of the balance.
  - 2 Connect the other end of the Ethernet cable to your local network.
  - 3 Navigate to the section 📡 **Interfaces**.
  - 4 Tap **Ethernet**.
  - 5 Keep the settings of the Ethernet connection at hand. This information might be required to set up the connection at a later stage.
  - 6 Tap ✓ **Save**.

## Configuring the service on the balance

☰ **Navigation:** ▶ **Balance menu** > ⚙️ **Settings** > 🏠 **LabX / Services**

- The balance is connected to the network via Ethernet.
- 1 Navigate to the section 🏠 **LabX / Services**.
- 2 Set **LabX service** to **Network**.
- 3 Note the port number. This information might be required to set up the connection at a later stage.
- 4 Tap ✓ **Save**.

### 5.7.2 MT-SICS service

All XPR and XSR balances can be integrated to a network and can be configured to communicate with a computer using MT-SICS (METTLER TOLEDO Standard Interface Command Set). The available commands depend on the functionality of the balance.

For further information, please contact your METTLER TOLEDO representative.

The full documentation related to MT-SICS for XPR and XSR balances is available online.

▶ [www.mt.com/labweighing-software-download](http://www.mt.com/labweighing-software-download)

#### See also

🔗 [LabX / Services](#) ▶ Page 86

#### 5.7.2.1 Using MT-SICS via a USB connection

This example describes how to establish a direct USB connection between your balance and a computer. The computer can then be used to control the balance and receive data using the commands of MT-SICS.

To establish this connection, the USB driver must be installed on your computer. The driver is available online:

▶ [www.mt.com/labweighing-software-download](http://www.mt.com/labweighing-software-download)

#### Connecting the balance to the computer

- A USB-A to USB-B cable is available.
- 1 Connect the USB cable to the USB-B port of the balance.
- 2 Connect the USB cable to a USB-A port on the computer.

#### Configuring the service on the balance

☰ **Navigation:** ▶ **Balance menu** > ⚙️ **Settings** > 🏠 **LabX / Services**

- 1 Navigate to the section 🏠 **LabX / Services**.
- 2 Set **MT-SICS** to **USB**.
- 3 Tap ✓ **Save**.

#### Configuring the computer

- The USB driver is installed on the computer.
- A terminal program is installed and running on the computer.
- 1 Provide the necessary connection settings to the terminal program.
- 2 Test the connection by sending a command to the balance, for example, `s` to retrieve the stable weight from the balance.
  - ➔ If a string is received by the terminal program with the weight, date, and time, the connection has been successfully established.
  - ➔ If no response is received by the terminal program, check the connection settings.

#### 5.7.2.2 Using MT-SICS via an Ethernet connection

This example describes how to establish a connection between a balance and a computer through a local network. The computer can then be used to controlled the balance and receive data using the commands of MT-SICS.



### Connecting the balance to the network

☰ **Navigation:** ▶ **Balance menu** > ⚙️ **Settings** > 🌐 **Interfaces**

- An Ethernet cable is available.
- 1 Connect the Ethernet cable to the Ethernet port of the balance.
- 2 Connect the other end of the Ethernet cable to your local network.
- 3 Navigate to the section 🌐 **Interfaces**.
- 4 Tap **Ethernet**.
- 5 Keep the settings of the Ethernet connection at hand. This information might be required to set up the connection at a later stage.
- 6 Tap ✓ **Save**.

### Configuring the service on the balance

☰ **Navigation:** ▶ **Balance menu** > ⚙️ **Settings** > 🌐 **LabX / Services**

- The balance is connected to the network via Ethernet.
- 1 Navigate to the section 🌐 **LabX / Services**.
- 2 Set **MT-SICS** to **Network**.
  - ➔ The port number appears in the list of settings.
- 3 Note the port number. This information might be required to set up the connection at a later stage.
- 4 Tap ✓ **Save**.

### Configuring the computer

- A terminal program is installed and running on the computer.
- 1 Provide the necessary connection settings to the terminal program.
  - ➔ The computer is connected to the same network and the same subnet as the balance.
- 2 Test the connection by sending a command to the balance, for example, `s` to retrieve the stable weight from the balance.
  - ➔ If a string is received by the terminal program with the weight, date, and time, the connection has been successfully established.
  - ➔ If no response is received by the terminal program, check the connection settings.

#### i **Note**

For more information, contact your network administrator.

## 5.7.3 Web service

The web service allows users to send commands to control and transfer data from the balance using a web browser.

### Connecting the balance to the network

☰ **Navigation:** ▶ **Balance menu** > ⚙️ **Settings** > 🌐 **Interfaces**

- An Ethernet cable is available.
- 1 Connect the Ethernet cable to the Ethernet port of the balance.
- 2 Connect the other end of the Ethernet cable to your local network.
- 3 Navigate to the section 🌐 **Interfaces**.
- 4 Tap **Ethernet**.
- 5 Keep the settings of the Ethernet connection at hand. This information might be required to set up the connection at a later stage.
- 6 Tap ✓ **Save**.

## Configuring the service on the balance

≡ **Navigation:** ▶ **Balance menu** > ⚙️ **Settings** > 🧪 **LabX / Services**

- The balance is connected to the network via Ethernet.
- The computer and the balance are connected to the same network.
- A web browser is available on the balance.

- 1 Navigate to the section 🧪 **LabX / Services**.
- 2 Activate and configure the service.
- 3 Tap ✓ **Save**.



The documentation of web service and related examples are available online.

▶ [www.mt.com/labweighing-software-download](http://www.mt.com/labweighing-software-download)

### **Note**

For more information, contact your network administrator.

## Exporting the WSDL definition file

The WSDL (Web Services Description Language) file describes the functionalities of the web service. The WSDL file can be exported as follows.

≡ **Navigation:** ▶ **Balance menu** > ⚙️ **Settings** > 🏠 **Balance** > ⚙️ **General**

- 1 Navigate to ⚙️ **General**.
- 2 Tap ⋮ **More**.
- 3 Tap **Export web service WSDL file**
  - ➔ A list of available target locations is shown, including the file server and any USB storage device connected to the balance.
- 4 Select the target device on which you want to store the data.
- 5 Tap → **Next**.
  - ➔ If the export was successful, the display shows 🟢 with the name of the file and the target folder.

### **See also**

🔗 [LabX / Services](#) ▶ Page 86

## 5.8 Data management

### 5.8.1 Exporting results

This example describes how to export results to a file server at the end of a task. A similar exporting procedure can be followed when using a USB storage device.

#### Connecting to a file server

≡ **Navigation:** ▶ **Balance menu** > ⚙️ **Settings** > 🧪 **LabX / Services**

- 1 Navigate to the section 🧪 **LabX / Services**.
- 2 Set **File server** to **Active**.
- 3 Tap **File server configuration**.
- 4 Tap **Server name** and type the name of your server.
- 5 Tap **Share name** and type the path of the shared folder that you want to use.
- 6 Tap **Credentials** in the action bar.
  - ➔ The dialog **Set file server credentials** appears.
- 7 Fill in your credentials (**Domain name**, **User name**, and **Password**) and tap ✓ **OK**.

➔ The credentials are saved on the balance.

8 Tap ✓ **OK** to establish the connection to the file server.

### Exporting the XSD file

Weighing results are exported in XML files. The description of the elements of the XML file is provided in an XSD (XML Schema Definition) file. The XSD file can be exported as follows.

#### **Note**

If the XSD file is used for validation, the version contained in the XML file must match the version of the XSD schema.

☰ **Navigation:** ▶ **Balance menu** > ⚙ **Settings** > 📁 **Balance** > ⚙ **General**

1 Navigate to ⚙ **General**.

2 Tap ⋮ **More**.

3 Tap **Export results XSD files**.

➔ A list of available target locations is shown, including the file server and any USB storage device connected to the balance.

4 Select the target device on which you want to store the data.

5 Tap → **Next**.

➔ If the export was successful, the display shows ✔ with the name of the target folder.

### Exporting weighing results

☰ **Navigation:** ▼ **Methods** > ☰ **Methods list**

■ An Ethernet connection is established.

■ A file server access is configured.

1 Select a method from the **Methods list**.

2 Tap ▶ **Start method**.

3 Perform the necessary actions to weigh your sample(s).

4 Tap 📄 **Complete** to open the export options.

➔ The dialog **Complete task** appears.

5 Tap **Export results manually** to export the results.

➔ A list of available target locations is shown, including the file server and any USB storage device connected to the balance.

6 Select **File server**.

7 Tap → **Next**.

➔ The system checks the credentials for the file server connection.

➔ The results are exported to the file server.

8 Tap ✓ **Complete**.

➔ After completing the task, the results are deleted from the **Results list**.

#### **See also**

 [LabX / Services ▶ Page 86](#)

## 5.8.2 Sending individual results to a computer

The balance offers the possibility to send weighing results to a computer via a USB connection. This feature can be used, for example, to send results to an Excel sheet, to a text file, or to MT-SICS. When used in mode **HID** (Human Interaction Device), the result is sent to the computer where the cursor is located, exactly as if it were a keyboard input (also referred to as "drop to cursor").

This example describes how to send weighing results from a method of type **General weighing** directly into an Excel file on a computer using the functionality **HID**.

## Connecting the balance to the computer

- A USB-A to USB-B cable is available.
- 1 Connect the USB cable to the USB-B port of the balance.
  - 2 Connect the USB cable to a USB-A port on the computer.

## Configuring the balance

≡ **Navigation:** ► **Balance menu** > ⚙ **Settings** > ⚖ **Balance** > ⚖ **Weighing / Quality**





- 1 Navigate to the section **⚖ Weighing / Quality**.
- 2 Tap **Automatic weight value output**.
- 3 Tap **Output mode** and select **Results**.
- 4 Tap **Target** and select **HID**.
- 5 Review the rest of the settings in the section **Automatic weight value output** to customize the output, for example, to add the date and time to each weighing result.

### **Note**

The right settings are highly dependent on your application. For example, when using an Excel sheet as the target, values separated with the character **TAB** will be placed in separate cells.

## Editing the method settings

≡ **Navigation:** ▼ **Methods** > ⌘ **Methods list**

- A method **General weighing** exists.
- 1 Select the method from the **Methods list**.
  - 2 Tap  **Edit**.
  - 3 Tap  **Print / Export**.
  - 4 Tap **Strip printout and data export**.
  - 5 Set **Weight value** to **Active**.
  - 6 Tap  **OK**.
  - 7 Tap  **Save**.
- ➔ The method is set up to send the results to the computer when tapping **Add result**.

## Running the method

- The USB driver is installed on the computer.
- 1 Select the method from the **Methods list**.
  - 2 Tap ► **Start method**.
  - 3 Perform the necessary actions to weigh your sample.
  - 4 Open an Excel sheet and place the cursor in a first target cell, for example, "A1".
  - 5 Tap  **Add result**.
    - ➔ The weighing result is saved to the **Results list**.
    - ➔ The weighing result is stored in cell "A1" of your Excel sheet.
    - ➔ If the character **TAB** is used as delimiter, the other weighing parameters are stored in cells "B1", "C1", etc.
    - ➔ If the character **Enter** is used to mark the end of the line, the cursor now appears in cell "A2".

### 5.8.3 Exporting and importing settings

The settings of the balance can be exported and imported. Transferring data from one balance to another is helpful, for example, to use the same method on several balances. It is also good practice to store the balance settings as backup before updating the software.

The following data can be imported and exported:

- **Balance settings**

- When importing these settings, the GWP status of the balance might change (**GWP Approved mode**).
- The balance might prompt to reboot.
- **User management**
  - When importing these settings, the existing settings on the balance are replaced.
- **Methods**
  - When importing methods, you can select if all methods or only selected methods are imported.
  - If importing a method with the same name as an existing method, you can select if you want the method to be overwritten or not.
- **Tests and weights**
  - When importing these settings, all the existing tests and test weights on the balance are erased and replaced by the imported data.

The data can be transferred via a USB storage device. For XPR balances, the data can also be transferred via a file server.



## NOTICE

### Data import can cause data loss

Importing data can delete user application data without warning.

### 5.8.3.1 Transferring test weight settings between balances

This example shows how to export test weight settings from one balance and import them on another balance. This procedure is particularly helpful if you are using the same calibrated weights to perform tests on several balances. The data is transferred using a USB storage device.

#### Exporting data and settings

☰ **Navigation:** ▶ **Balance menu** > **Maintenance** > **Import / Export**

- A USB storage device is connected to the balance.
- 1 Navigate to the section **Import / Export**.
  - ➔ The dialog **Import / Export** opens.
- 2 Select **Export data and settings** and tap → **Next**.
  - ➔ The dialog **Export data and settings** opens.
- 3 Deactivate all data types except **Tests and weights**.
- 4 Tap ✓ **Export**.
  - ➔ A list of available USB storage devices is shown.
- 5 Select the target USB storage device to store the data.
- 6 Tap → **Next**.
  - ➔ The system exports the data to the USB storage device.
  - ➔ If the export was successful, the display shows with the name of the file and the target folder.
- 7 Tap ✕ **Close** to finish the process.

#### Importing data and settings

☰ **Navigation:** ▶ **Balance menu** > **Maintenance** > **Import / Export**

- A USB storage device containing the data to import is connected to the balance.
- 1 Navigate to the section **Import / Export**.
  - ➔ The dialog **Import / Export** opens.
- 2 Select **Import data and settings** and tap → **Next**.
  - ➔ A list of available USB storage devices is shown.
- 3 Select the USB storage device containing the data to import.

- 4 Tap → **Next**.
- 5 Select which file you want to import.
- 6 Tap → **Next**.
- 7 To import only the test weights, select the data type **Test weights**.
- 8 Tap ✓ **Import**.
  - ➔ The system imports the data from the USB storage device.
  - ➔ If the import was successful, the message **Import of data and settings has been executed**. appears.
- 9 Tap ✕ **Close** to finish the process.

## 5.9 User management



### NOTICE

#### Loss of data due to missing password or User name

Protected menu areas cannot be accessed without **User name** or password.

- Note **User name** and password and keep them in a safe place.

### 5.9.1 Activating the user management

≡ **Navigation:** ▶ **Balance menu** > ⚙️ **Settings** > 🏠 > **Balance** > ⚙️ **General** > **User management**

The user management is disabled in the factory settings. To activate the user management follow:

- 1 Tap ⓘ and select **Active**.
  - ➔ The dialog **Activate user management** opens.
- 2 Tap → **Next**.
  - ➔ The dialog 🔑 **Set administrator password (optional)** opens.
- 3 Tap **New password** and enter the new password.
- 4 Confirm the new password again and tap ✓ **OK**.
  - ➔ The dialog closes.
- 5 Confirm the activated user management in the section **General**, tap ✓ **OK**.
  - ➔ The **User management** is active. The login dialog opens at every system start.

### 5.9.2 Disabling the user management

≡ **Navigation:** ▶ **Balance menu** > ⚙️ **Settings** > 🏠 > **Balance** > ⚙️ **General** > **User management**

- 1 Tap ⓘ and select **Inactive**.
  - ➔ The dialog **Deactivate user management** opens.
- 2 Tap → **Next**.
  - ➔ The dialog 🔑 **Set unblocking password** opens.
- 3 Tap **New password** and enter the new password.
- 4 Confirm the new password again and tap ✓.
  - ➔ The dialog closes.
- 5 Tap ✓ **OK** to confirm.
  - ➔ The user management is inactive.

### 5.9.3 Managing users and user groups

The **Users** settings are only visible when the **User management** is set to **Active**.

☰ **Navigation:** ▶ **Balance menu** > 👤 **Users**

### Printing user list

An overview of all users and user groups can be printed by tapping 🖨️ **Print all**.

### See also

🔗 [Activating the user management](#) ▶ Page 64

#### 5.9.3.1 Creating a new user

☰ **Navigation:** ▶ **Balance menu** > 👤 **Users** > 👤 **Users**

- 1 Tap **+** **New user** in the action bar.
- 2 Define the values for the new user.
- 3 To define a user profile password, tap 🔑 **Change password** in the action bar.
- 4 Tap **New password**.
  - ➔ The keyboard dialogue opens.
- 5 Define the password.
- 6 Tap **Confirm new password** and fill in the defined password.
- 7 Tap ✓ to close the keyboard dialogue.
- 8 Tap ✓ **OK** to confirm the defined password.
  - ➔ The dialogue **User name** opens.
- 9 Tap ✓ **OK** to confirm the defined user profile.
  - ➔ The user has been created. The new user profile appears in the list.

#### 5.9.3.2 Creating a new group

☰ **Navigation:** ▶ **Balance menu** > 👤 **Users** > 👤 **Groups**

##### 📘 **Note**

This area is only accessible for users with the appropriate rights.

- 1 Tap **+** **New group**.
  - ➔ The dialog opens.
- 2 Define the group properties.
- 3 Tap ✓ **OK**.
  - ➔ The group has been created, the system returns to the list of defined groups.

#### 5.9.3.3 Deleting users or user groups

Requirements for deleting:

- You logged in as administrator.

☰ **Navigation:** ▶ **Balance menu** > 👤 **Users** > 👤 **Users**

- 1 Select the **User name** of the user to delete.
  - ➔ The user management dialog opens.
- 2 Tap 🗑️ **Delete** in the action bar.
  - ➔ The dialog **Delete user** opens.
- 3 To delete the user tap ✓ **OK**.
  - ➔ The user is deleted irreversibly.

## 5.10 Tolerance profiles

☰ **Navigation:** ▶ **Balance menu** > ⚙️ **Settings** > ⚖️ **Balance** > ⚖️ **Weighing / Quality** > **Tolerance profiles**

### Creating a Tolerance profile

- 1 Tap **+** **New** to create a new profile.
- 2 Define the profile settings.
- 3 When all the settings have been defined, tap **✓ OK**.
  - ➔ The system returns to the profile list and the new profile appears on the list.

By tapping an existing profile, its settings can be changed, the profile can be deleted or it can be set as default value. Several profiles can be created. A default profile must be selected.

If changes are made to the default tolerance profile, the status of the routine tests will be set to **Never executed**.

## 5.11 Password protection and balance reset

### 5.11.1 Password protection

If user management is active, each user has an individual password.

- Any logged in user can change his own password. See [Changing a password ▶ Page 66].
- Users with permission to configure user management can change the password of any user. See [Changing a password ▶ Page 66].
- If a user with permission to configure user management has forgotten his password (and no other user can change it), a password reset can be requested. See [Requesting a reset password ▶ Page 66]

#### **Note**

If the parameter **Password reset** is set to **Not allowed**, the balance needs to be reset by a service technician.

If user management is inactive, a password can be generated to block the whole balance. See [Creating an unblocking password ▶ Page 67].

#### 5.11.1.1 Changing a password

Any user can change its own password. Additionally, users with permission to configure user management can change the password of other users.

☰ **Navigation:** ▶ **Balance menu** > 👤 **Users** > 👤 **Users**



- 1 Select the **User name** for which the password should be changed.
  - ➔ The user management dialog opens.
- 2 Tap **🔑 Change password** in the action bar.
  - ➔ The dialog **Change password** opens.
- 3 Enter a new password and confirm it.
  - Note**  
Any password is valid.
- 4 Tap **✓ OK**.
  - ➔ The password has been changed.

#### 5.11.1.2 Requesting a reset password

If a user with the permission to configure user management has forgotten his password, a reset password can be requested.

- The balance login dialog is open.
- 1 Select the user who needs a password reset. That user needs to have the permission to configure user management.
  - 2 Tap **⋮ More**.







- ➔ The dialog **More** opens.
- 3 Tap  **Request reset password**.
- 4 The dialog **Request reset password** opens.
- 5 Note the service code and tap  **Service request**.
  - ➔ Information about your METTLER TOLEDO service representative appears.
- 6 Contact your METTLER TOLEDO service representative via phone or email.
  - ➔ You get an 8-character reset password with which you can log in once.
- 7 Log in with your reset password and select a new password.

### 5.11.1.3 Creating an unblocking password

If the user management is inactive, the balance can still be blocked with a unique password, called the unblocking password. This password first need to be generated and needs to be provided to block and unblock the balance.

☰ **Navigation:** ▶ **Balance menu** >  **Settings** >  **Balance** >  **General**

- 1 To create an unblocking password, tap  **Unblocking password** in the action bar.
  - ➔ The dialog **Set unblocking password** opens.
- 2 Set a new password, confirm it, and tap  **OK**.
- 3 In the dialog  **General**, tap  **Save** and  **OK**.
  - ➔ The unblocking password is created.

## 5.11.2 Logging in and logging out

If the user management is active, users need to log in to use the balance.

### 5.11.2.1 Logging in

- The balance login dialog is open.
- 1 Select a user and enter the password.
- 2 Tap  **Login**.
  - ➔ You are logged in and your user name is displayed on the main weighing screen.

### 5.11.2.2 Logging out

**Navigation:** ▶ **Balance menu** >  **Exit/ Block balance**

- Tap  **Logout**.
  - ➔ You are logged out.

## 5.11.3 Blocking and unblocking the balance

A blocking means closedown of the balance. A reason for such "full blocking" can have a serious background. If the balance has a defect or a loss of the weighing quality, the user can block the balance completely.

If user management is active, users can block the balance if they have the related permission.

If user management is inactive, the balance can still be blocked to prevent any further usage of the balance. If no unblocking password has been set, the balance can get blocked and unblocked without a password. If an unblocking password has been set, the balance can only get blocked and unblocked using this password. See [Creating an unblocking password ▶ Page 67].

### 5.11.3.1 Blocking the balance

☰ **Navigation:** ▶ **Balance menu** >  **Blocking**

- 1 To block the balance, tap  **Block balance**.
  - ➔ The dialog **Block balance** opens.

- 2 Tap → **Next**.
- 3 Enter your unblocking password and tap ✓ **Block balance**.
  - ➔ The balance is blocked and the blocking screen appears.

### 5.11.3.2 Unblocking the balance

- The balance is blocked and the blocking screen is open.
- 1 Tap  **Unblock balance**.
  - 2 Type in the unblocking password, if applicable.
  - 3 Tap ✓ **Unblock balance** to confirm.
    - By tapping ✕ **Cancel** instead, the main weighing screen appears, but the balance is still blocked and only a limited number of settings can be edited.
- ➔ The balance is unblocked and the main weighing screen appears.

### 5.11.4 Resetting the balance

When user management is active, only users with the appropriate permissions can reset the balance.

≡ **Navigation:** ▶ **Balance menu** >  **Maintenance** > ↺ **Reset**



#### NOTICE

##### Reset causes data loss

Resetting the balance will delete user application data and set the user configuration back to factory state.

- 1 To delete the change history data and the data for test history and adjustment history, activate the option **Also delete change, test and adjustment history**.
- 2 Tap → **Next**.
  - ➔ The window **Reset balance** opens and warns that some data will be lost by resetting the balance.
- 3 Tap ↺ **Reset balance**.
  - ➔ The balance software restarts in factory state. The alibi memory settings and alibi entries remain unchanged.

## 5.12 Automated dosing

Automated dosing methods, namely **Automated dosing** and **Automated solution prep.**, can only be performed on XPR analytical automatic balances. However, any XPR balance connected to an RFID reader can be used to read/edit the data from any dosing head.

### 5.12.1 Managing the dosing head data



Each dosing head includes an RFID tag that can exchange data with the instrument. You can remove the dosing head and insert it into another dosing module or liquid module, where the data is immediately available.

#### **Note**

The data on the RFID tag of the dosing head can also be managed by any XPR balance equipped by an external RFID reader.

≡ **Navigation:** ▼ **Methods** >  **Manual operations** >  **Manage dosing head data**

#### Editing the dosing head data

- 1 Tap  **Manage dosing head data**.
  - ➔ The dialog box opens in which the dosing head data is displayed.
- 2 Tap  **Edit** to edit the data of the attached dosing head.

- 3 Tap **OK** to save the data.

### Copying the dosing head data

The data stored on a dosing head can be copied to another dosing head with this function. Re-entering all the required data on a new dosing head with the same or similar substances is not necessary.

- A first dosing head, from which data will be copied, is attached to the dosing or liquid module.
- A second dosing head, on which the data will be saved, is available.

- 1 Tap **Manage dosing head data**.
  - ➔ The dialog box opens in which the dosing head data is displayed.
- 2 Tap **Copy** to copy the data of the attached dosing head.
- 3 Follow the instructions from the wizard.

### Available fields for dosing head data

Depending on the type of dosing head, the following data is stored on the RFID tag.

Parameter	Description	Values
Substance	Specifies the name of the substance.	Text (0...20 characters)
Lot ID	Defines the batch identification.	Text (1...15 characters)
Verify expiry date before dosing	Defines whether the expiry date is verified before dosing.	Active   Inactive*
Expiry date	Specifies the expiry date of the substance.	Date
Set the filling date	Defines whether the filling date must be specified.	Active   Inactive*
Filling date	Specifies the date when the dosing head was filled.	Date
ID 1 field label... ID 3 field label	Defines the label of the user-defined fields.	Text (0...10 characters)
ID 1 value...ID 3 value	Defines the values of the user-defined fields.	Text (0...15 characters)
Molar mass	Defines the molar mass of the substance.	Numeric (1...10000 g/mol)
Purity	Defines the purity of the substance.	Numeric (0.001...100%)
Density	Defines the liquid density. This field is only available for liquid dosing heads.	Numeric (1 g/ml*   0.01...10 g/ml)
Verify quantity before dosing	Defines whether the remaining quantity in the dosing head is verified before dosing.	Active   Inactive*
Remaining quantity	Residual quantity of substance in the dosing head. When filling the dosing head, insert the weight of the substance in this field. To use the weight on the weighing pan, tap .	Numeric (0.01...999999 mg)
Verify dose limit before dosing	Defines whether the dose limit of the dosing head is verified before dosing. This field is only available for powder dosing heads.	Active*   Inactive
Remaining doses	Shows the number of dosing operations still available with this dosing head, before reaching the <b>Dose limit</b> . The <b>Remaining doses</b> is calculated based on the <b>Dose limit</b> and the <b>Number of total dosages</b> . This field is only available for powder dosing heads. It is only available when <b>Verify dose limit before dosing</b> is set to <b>Active</b>	Numeric
Dose limit	Specifies the maximum number of dosing operations with this dosing head. This field is only available for powder dosing heads.	Numeric (250*   0...50000)

Number of total dosages	Shows the number of dosing operations performed with this dosing head until now. This field is only available for powder dosing heads. It is only available when <b>Verify dose limit before dosing</b> is set to <b>Active</b> .	Numeric
Tapping while dosing	Activates the automatic start of the tapper during dosing. Note that tapping can lead to compacting effects with some powders. This field is only available for powder dosing heads.	Active*   Inactive
Tapping before dosing	Activates the automatic start of the tapper before each dosing. Note that tapping can lead to compacting effects with some powders. This field is only available for powder dosing heads.	Active   Inactive*
Pump pressure	Defines the pump pressure for the liquid dosing operation. This field is only available for liquid dosing heads.	0.3   0.4   0.5 bar*
Dosing head type	Shows the type of the dosing head.	Text
Dosing head ID	Shows the unique ID of the dosing head.	Text

\* Factory setting

### 5.12.2 Changing the pump pressure







The pump pressure can be adjusted, depending on the liquid and dosing head used. The pump pressure is saved as a setting on the dosing head, see [Managing the dosing head data ► Page 68].

## 6 Software Description

### 6.1 Balance menu settings

The **Balance menu** contains general settings and information. To open the section **Balance menu** tap the tab with the symbol  on the left side of the screen.

The section **Balance menu** is divided into the following subsections.

-  **Leveling aid**, see [Leveling aid ▶ Page 71]
-  **History**, see [History ▶ Page 71]
-  **Balance info**, see [Balance info ▶ Page 73]
-  **Users** (only appears when user management is activated), see [Users ▶ Page 73]
-  **Settings**, see [Settings ▶ Page 75]
-  **Maintenance**, see Maintenance

#### 6.1.1 Leveling aid

Exact horizontal positioning and stable installation is essential for repeatable and accurate weighing results. With the **Leveling aid** the balance can be leveled.

≡ **Navigation:** ▶ **Balance menu** >  **Leveling aid**

##### **Note**

After leveling the balance an internal adjustment must be performed.

##### **See also**

 [Leveling the balance ▶ Page 29](#)

#### 6.1.2 History

The balance permanently records the tests and adjustments that are performed in the section **History**

≡ **Navigation:** ▶ **Balance menu** >  **History**



The section **History** is divided into the following subsections.

-  **Adjustments**
-  **Tests**
-  **Service**
-  **Changes** (only appears when change history is activated)

##### 6.1.2.1 Adjustments

≡ **Navigation:** ▶ **Balance menu** >  **History** >  **Adjustments**



A maximum of 500 entries can be stored in the adjustments history.

Button	Name	Description
	Filter	Tap to filter the list: <ul style="list-style-type: none"><li>• <b>By date range</b></li><li>• <b>By user name</b></li></ul>
	Print	Tap to print the displayed entries.
	Close	Tap to return to the section <b>History</b> .

### 6.1.2.2 Tests

≡ Navigation: ▶ Balance menu >  History >  Tests



A maximum of 500 entries can be stored in the test history.

Button	Name	Description
	Filter	Tap to filter the list: <ul style="list-style-type: none"><li>• <b>By date range</b></li><li>• <b>By user name</b></li></ul>
	Print	Tap to print the displayed entries.
	Close	Tap to return to the section <b>History</b> .

### 6.1.2.3 Service

≡ Navigation: ▶ Balance menu >  History >  Service

A maximum of 500 entries can be stored in the service history.

Button	Name	Description
	Filter	Tap to filter the list: <ul style="list-style-type: none"><li>• <b>By date range</b></li><li>• <b>By technician</b></li></ul>
	Print	Tap to print the displayed entries.
	Close	Tap to return to the section <b>History</b> .



### 6.1.2.4 Changes

The function **Change history** is an administration tool to improve the traceability of the weighing process. Information such as added methods or settings changes are being listed. Tap into the list to display detailed information about the data.

≡ Navigation: ▶ Balance menu >  History >  Changes

**Change history** is deactivated in the factory settings. To activate **Change history**, see [Weighing / Quality ▶ Page 76].

A maximum of 5000 entries can be stored in the change history.



Button	Name	Description
	Filter	Tap to filter the list: <ul style="list-style-type: none"><li>• <b>By date range</b></li><li>• <b>By user name</b></li></ul>
	Print	Tap to print the displayed entries.
	Close	Tap to return to the section <b>History</b> .

### 6.1.3 Balance info

☰ **Navigation:** ▶ **Balance menu** >  **Balance info**

The section **Balance info** shows information about the specific balance about:

- **Identification**
- **Hardware**
- **Software**
- **Maintenance**

Button	Name	Description
	<b>License agreement</b>	Tap to open the licence agreement.
	<b>Close</b>	Tap to return to the <b>Balance menu</b> .



### 6.1.4 Users

In the section **Users**, rights for users and user groups can be defined. Users can be assigned to user groups. When the user management is active, the login dialog opens at every system start.

The **Users** settings are only visible when the **User management** is set to **Active**.

☰ **Navigation:** ▶ **Balance menu** >  **Users**

The section **User management** is divided into the following subsections:

-  **General**: settings for all users
-  **Users**: settings for individual users
-  **Groups**: settings for user groups

An unlimited number of users can be created. A user is always a part of a user group and has the permissions of the group in which he is. Which user has which permissions can be defined or changed by users with the appropriate permission rights.

#### See also

 [Activating the user management ▶ Page 64](#)

#### 6.1.4.1 General

☰ **Navigation:** ▶ **Balance menu** >  **Users** >  **General**

Parameter	Description	Values
Automatic logout	Defines if the user is automatically logged out after a predefined <b>Wait time</b> .	Active*   Inactive
Wait time	Defines after how long the user automatically gets logged out when no activity is recorded on the balance. This setting is only available if <b>Automatic logout</b> is set to <b>Active</b> .	Numeric (15 minutes*   1...60 minutes)
User proposals	Defines if a list of users appears on the login screen. <b>Active</b> : A list of all users appears, from which a <b>User name</b> can be selected. <b>Inactive</b> : The user needs to type in his <b>User name</b> by hand at login.	Active*   Inactive

Password reset	Defines if the password can be reset from the login screen. If set to <b>Not allowed</b> and the password is lost, a new password cannot be requested. The balance needs to be reset and all data and settings will be lost.	Allowed*   Not allowed
----------------	---	------------------------

\* Factory setting

## 6.1.4.2 Users

Navigation: ► Balance menu > 👤 Users > 👤 Users

Parameter	Description	Values
User name	Defines a unique identifier for the user. When the user profile has been defined, the value for <b>User name</b> will be fixed and cannot be changed afterwards.	Text (1...22 characters)
Last name	Defines the last name of the user.	Text (0...22 characters)
First name	Defines the first name of the user.	Text (0...22 characters)
Active	Activates or deactivates the current user.	Active*   Inactive
Assigned groups	Assigns user to user groups.	List of defined groups
User language	Defines the language of the user profile.	Available languages

\* Factory setting

An unlimited number of users can be created. A user is always a part of a user group and has the permissions of the group in which he is. Which user has which permissions can be defined or changed by users with the appropriate permission rights.

## 6.1.4.3 Groups

Navigation: ► Balance menu > 👤 Users > 👤 Groups

### Note

This area is only accessible for users with the appropriate rights.

Parameter	Description	Values
Group name	Defines the name of the group.	Text (1...22 characters)

### General permissions

Parameter	Description	Values
Block / unblock balance	Defines if the group is allowed to block or unblock the balance.	Active   Inactive
Configure methods	Defines if the group is allowed to: <ul style="list-style-type: none"> <li>• create new methods</li> <li>• edit methods</li> <li>• delete methods</li> <li>• lock or unlock methods</li> <li>• import or export methods</li> </ul>	Active   Inactive
Execute service commands	Defines if the group is allowed to: <ul style="list-style-type: none"> <li>• access service function</li> <li>• block/unblock the balance</li> <li>• view adjustment state</li> <li>• generate support files</li> </ul>	Active   Inactive



Configure system	Defines if the group is allowed to: <ul style="list-style-type: none"> <li>• modify system settings</li> <li>• import system settings</li> <li>• configure peripherals</li> <li>• perform software updates</li> <li>• perform application or factory settings</li> </ul>	Active   Inactive
Configure user management	Defines if the group is allowed to: <ul style="list-style-type: none"> <li>• print or export/import user management settings</li> <li>• modify user management settings</li> <li>• enable or disable user management</li> </ul>	Active   Inactive
Cancel task	Defines if the group is allowed to cancel a task during the execution of a method.	Active   Inactive
Exclude / Overwrite result	Defines if the group is allowed to exclude or overwrite results in the <b>Results list</b> .	Active   Inactive
Reset the time span statistics	Defines if the group is allowed to: <ul style="list-style-type: none"> <li>• reset the time span statistics when using the method <b>SQC</b></li> </ul>	Active   Inactive

### Quality management permissions

Parameter	Description	Values
Start external adjustment	Defines if the group is allowed to perform external adjustments.	Active   Inactive
Show change history	Defines if the group is allowed to see the <b>Change history</b> .	Active   Inactive
Configure routine tests / GWP	Defines if the group is allowed to: <ul style="list-style-type: none"> <li>• configure routine tests</li> <li>• import or export routine tests</li> <li>• configure and import test weights</li> <li>• configure tolerance profiles</li> <li>• activate/deactivate the GWP approval mode</li> </ul>	Active   Inactive
Start routine tests	Defines if the group is allowed to perform routine tests.	Active   Inactive





The settings related to the screen brightness and the sound can be edited by all users and changes are applied to all users. Any user can set a user-specific language for the balance interface without influencing the settings of other users.

## 6.1.5 Settings

This section describes the settings of the balance that can be changed to suit specific requirements. The balance settings apply to the entire weighing system and to all users.

### Navigation: ► Balance menu > ⚙ Settings

The section **Settings** is divided into the following subsections:

-  **Balance**
-  **Modules / Dosing**
-  **Interfaces**
-  **Devices / Printers**
-  **LabX / Services**

## 6.1.5.1 Balance

≡ Navigation: ► Balance menu > ⚙ Settings > ⚖ Balance

The section **Balance** is divided into the following subsections:

- ⚖ Weighing / Quality
- 🌐 Date / Time / Language / Format
- 🔊 Screen / StatusLight / Sound
- ⚙ General

### Weighing / Quality

≡ Navigation: ► Balance menu > ⚙ Settings > ⚖ Balance > ⚖ Weighing / Quality

Parameter	Description	Values
Leveling warning	<p>Defines the action when the balance is out of level</p> <p>When <b>Forced leveling</b> is selected and the balance is out of level, no weighing value can be added to the <b>Results list</b> (green button disabled).</p> <p>For approved balances, this setting is set to <b>Forced leveling</b> and cannot be edited.</p>	Inactive   Optional leveling*   Forced leveling
Electrostatic detection	<p>Defines the condition of the environment for the electrostatic detection.</p> <p><b>Standard environment:</b> Choose this option if operating in a stable environment.</p> <p><b>Unstable environment:</b> Choose this option if operating in an unstable environment, i.e. where <b>Standard environment</b> setting is not enough for the balance to determine the electrostatic weighing error.</p>	Standard environment*   Unstable environment
Tolerance profiles	<p>A tolerance profile stores all the necessary balance settings needed for a certain weighing method. It is possible to create different tolerance profiles for different weighing methods.</p> <p>This section contains several settings that are described in the table <b>Tolerance profiles</b> below.</p>	
Automatic weight value output	<p>Defines if and in which manner (<b>MT-SICS</b> and/or <b>HID</b>) the weighing values should be exported.</p> <p>This section contains several settings that are described in the table <b>Automatic weight value output</b> below.</p>	

GWP Approved mode	<p>Good Weighing Practice (GWP®) is a program started by METTLER TOLEDO to help customers operate their weighing equipment in a safe and efficient way. It covers every relevant step in the life cycle of the instrument and provides clear guidance on how to specify, calibrate and operate weighing instruments.</p> <p>The GWP Approved mode observes if the following conditions are given:</p> <ul style="list-style-type: none"> <li>• Use of an appropriate tolerance profile.</li> <li>• The internal adjustment was successful.</li> <li>• Required tests were successful.</li> <li>• Setting up of enforced leveling.</li> <li>• No MinWeigh violation.</li> </ul> <p>If all conditions are given, the balance adds the GWP Approved sign behind every weighing result.</p> <p>The <b>GWP Approved mode</b> can only be enabled by a METTLER TOLEDO service technician.</p>	Active   Inactive*
Change history	<p>The change history is used to log changes to system settings, user management and methods as well as other settings and configurations. The following information is stored:</p> <ul style="list-style-type: none"> <li>• User ID and timestamp</li> <li>• Object identifier</li> <li>• Old values and new values of attributes</li> </ul> <p>A maximum of 5000 entries can be stored in the change history. For more information see [Changes ▶ Page 72].</p>	Active   Inactive*
Balance recalib. reminder	Defines whether the user is reminded about the upcoming expiry date of the calibration.	Active*   Inactive
Days in advance	<p>Defines the number of days before the due date the recalibration reminder is shown.</p> <p>This setting is only available if <b>Balance recalib. reminder</b> is set to <b>Active</b>.</p>	Numeric (30 days*   0...400 days)
Action when calib. expired	<p>Defines the action when the calibration has expired.</p> <p><b>Block:</b> The balance will be blocked. In this case, the balance cannot be used anymore until a user unblocks the balance. If <b>User management</b> is <b>Active</b>, only users with the appropriate rights can unblock the balance.</p>	None*   Block
Days before blocking	Defines the number of days before the reminder informs about the upcoming expiry date.	Numeric (30 days*   0...400 days)
Weight recalib. reminder	Defines whether the user is reminded about the upcoming expiry date of the test weight calibration.	Active   Inactive*
Days in advance	<p>Defines the number of days before the due date the recalibration reminder is shown.</p> <p>This setting is only available if <b>Weight recalib. reminder</b> is set to <b>Active</b>.</p>	Numeric (30 days*   0...400 days)
Service reminder	Defines whether the user is reminded about the upcoming due date of the service.	Active   Inactive*
Days in advance	<p>Defines the number of days before the due date the service reminder is shown.</p> <p>This setting is only available if <b>Service reminder</b> is set to <b>Active</b>.</p>	Numeric (30 days*   0...400 days)

\* Factory setting

## Tolerance profiles

Settings relating to weighing performance and data from balance calibration can be stored in a tolerance profile.

For more information about creating tolerance profiles, see [Tolerance profiles ▶ Page 66]

Parameter	Description	Values
Name	Defines the name of the profile.	Text (0...22 characters)
Indicator	Defines the color of the indicator icon for the tolerance profile. The icon will appear above the weighing value unit. When a color is selected, a description of maximum 3 characters can be added.	None*   Neutral   White   Yellow   Red   Blue   Green   Black
Indicator text	Defines the text of the indicator icon.	Text (0...3 characters)
Calibration certificate	Selects a calibration certificate from a drop-down list of certificates available on the balance. New certificates can only be created by a service technician based on a performed balance calibration.	Calibration certificate   None*
Environment	Defines the environmental conditions of the balance. <b>Very stable:</b> For an environment that is free from any drafts and vibrations. <b>Stable:</b> For an environment that is practically free from drafts and vibrations. <b>Standard:</b> For an average working environment subject to moderate variations in the ambient conditions. <b>Unstable:</b> For an environment where the conditions are from time to time changing. <b>Very unstable:</b> For an environment where the conditions are continuously changing.	Very stable   Stable   Standard*   Unstable   Very unstable
Weighing mode	Defines the filter settings of the balance. <b>Universal:</b> For all standard weighing applications. <b>Sensor mode:</b> Depending on the setting of the ambient conditions, this setting delivers a filtered weighing signal of varying strength. The filter has a linear characteristic in relation to time (not adaptive) and is suitable for continuous measured value processing.	Universal*   Sensor mode
Value release	Defines the speed at which the balance regards the measured value as stable and available for capture. <b>Very fast:</b> recommended if you require fast results and repeatability is not very important. <b>Very reliable:</b> provides very good repeatability of the measured results but prolongs the stabilization time. Some intermediate settings can also be chosen from.	Very fast   Fast   Fast and reliable*   Reliable   Very reliable
Display readability	Determines the readability <b>d</b> of the balance display. <b>1d:</b> Shows the maximum resolution <b>2d:</b> 2 times smaller resolution <b>5d:</b> 5 times smaller resolution <b>10d:</b> 10 times smaller resolution <b>100d:</b> 100 times smaller resolution <b>1000d:</b> 1000 times smaller resolution For approved balances, the values available for this setting depend on the balance model.	1d*   2d   5d   10d   100d   1000d

Zero drift compensation	The function <b>Zero drift compensation</b> performs ongoing corrections of deviations from zero which may occur, for example, as a result of small amounts of dirt on the weighing pan.  For approved balances, the values available for this setting depend on the balance model.	Active*   Inactive
Allowed units	Defines the units that are allowed in this tolerance profile.	The available values are model-specific.

\* Factory setting

### Automatic weight value output

The balance can be connected to a computer with a USB cable. Weighing results can then be directly transferred to a target application, e.g., Microsoft Excel.

Parameter	Description	Values
Output mode	Defines which weighing values are transferred via the communication interface, e.g., USB, Ethernet.  <b>Results:</b> The weighing values are transferred only when they are added to the <b>Results list</b> .  <b>Continuous:</b> The weighing values are transferred continuously via the interface defined under <b>LabX / Services &gt; MT-SICS</b> . Additional fields are available, depending on the chosen option.	Results*   Continuous
Target	Defines the way the weighing values are transferred.  <b>HID</b> (Human Interaction Device): Transfers simple character streams (e.g. weight values) to a desktop computer without installing additional drivers (comparable to a keyboard). The format of a transferred weighing value can be configured.  <b>MT-SICS:</b> The data is transferred in MT-SICS format (METTLER TOLEDO Standard Interface Command Set). MT-SICS operates bidirectional, i.e. usually balance sends the confirmations to the host and receives commands. A separate reference manual is available for MT-SICS.  <b>HID / MT-SICS:</b> The data is transferred in HID and MT-SICS format in parallel.  <b>MT-SICS configurable:</b> The data is transferred in a user-defined MT-SICS format.  This setting is only available if <b>Output mode</b> is set to <b>Results</b> .	HID*   HID / MT-SICS   MT-SICS   MT-SICS configurable
Result ID 1 Result ID 2	Defines if the fields <b>Result ID 1</b> and <b>Result ID 2</b> are included in the output, respectively. Supported characters are: <ul style="list-style-type: none"> <li>• numbers: 0 – 9</li> <li>• letters: a – z and A – Z</li> <li>• special characters: space, dot, comma, semicolon, plus, minus</li> </ul> Non-supported characters will be replaced by a space. This setting is only available if <b>Output mode</b> is set to <b>Results</b> .	Active   Inactive*
Date	Defines if the field <b>Date</b> is included in the output. The format of the date is <b>YYYY-MM-DD</b> . This setting is only available if <b>Output mode</b> is set to <b>Results</b> .	Active   Inactive*

Time	Defines if the field <b>Time</b> is included in the output. The format of the time is <b>hh-mm-ss</b> . This setting is only available if <b>Output mode</b> is set to <b>Results</b> .	Active   Inactive*
Net indicator	In the standard output format, net weights are not specially marked. To place an N in front of net weights, this function can be activated. The net symbol is left-justified in the field. This setting is only available if <b>Output mode</b> is set to <b>Results</b> .	Active   Inactive*
Net indicator field length	Defines the field length of the Net indicator. This setting is only available if <b>Output mode</b> is set to <b>Results</b> and <b>Net indicator</b> is set to <b>Active</b> .	Numeric (2*   1...2)
Weight field length	Defines the number of digits that will be transferred into the application on the computer, e.g., into an Excel field. This setting is only available if <b>Output mode</b> is set to <b>Results</b> .	Numeric (1*   0...20)
Sign	Defines if the weighing result is displayed with an algebraic sign. <b>For all values:</b> Each weighing result is preceded by a plus or minus sign. <b>For negative values:</b> Only negative values are preceded by a minus sign. Positive values are transferred without algebraic sign. This setting is only available if <b>Output mode</b> is set to <b>Results</b> .	For all values   For negative values*
Sign position	Defines if the algebraic sign is positioned at the first place of the weight field or directly in front of the weight digits. This setting is only available if <b>Output mode</b> is set to <b>Results</b> .	Left of weight field   Left of weight digits*
Decimal delimiter	Defines the character used to separate the whole and fractional part of a numeric value. This setting is only available if <b>Output mode</b> is set to <b>Results</b> .	,   .*
Unit	Defines if a weighing unit is being shown in the weighing field. This setting is only available if <b>Output mode</b> is set to <b>Results</b> .	Active*   Inactive
Unit field length	Defines the field length of the weighing unit. This setting is only available if <b>Output mode</b> is set to <b>Results</b> and <b>Unit</b> is set to <b>Active</b> .	Numeric (1*   1...6)
Field delimiter	Defines a character or sequence of characters to separate data fields. This setting is only available if <b>Output mode</b> is set to <b>Results</b> .	None   Space*   TAB   ,   ;
End of line character	Defines a character or sequence of characters signifying the end of a line. This setting is only available if <b>Output mode</b> is set to <b>Results</b> .	CRLF   CR   LF   TAB   None   Enter*
Updates/sec.	Defines the rate at which data is transferred. This setting is only available if <b>Output mode</b> is set to <b>Continuous</b> .	2   5   6*   10
Format	Defines the format of the transferred data. This setting is only available if <b>Output mode</b> is set to <b>Continuous</b> .	MT-SICS*   PM   AT/MT

\* Factory setting

## Date / Time / Language / Format

Navigation: ► Balance menu > ⚙ Settings > ⚖ Balance > 🌐 Date / Time / Language / Format

Parameter	Description	Values
Date	Defines the current date.	Date

Time	Defines the current time. Use the plus/minus buttons to define the time.	Time
Language	Defines the language of the interface navigation.	English   Deutsch   Français   日本語   中文   Español   Italiano   Русский   Português   Polski   Magyar   Čeština
Time zone	Selects a time zone. When the time zone is set, the balance changes automatically between summer and winter time.	see list on the screen
Date format	Selects the date format.	D.MMM.YYYY*   MMM D YYYY   DD.MM.YYYY   MM/DD/YYYY   YYYY-MM-DD   YYYY/MM/DD   YYYY年M月D日
Time format	Selects the time format.	24:MM*   12:MM   24.MM   12.MM
Keyboard layout	Defines the language of the keyboard layout.	English   German   French   Spanish   Japanese   Simplified Chinese   Russian   Czech   Polish   Hungarian
System defaults	Defines the default settings that are applied for newly created users.  This setting is only available if <b>User management</b> is set to <b>Active</b> .	

\* Factory setting

## Screen / StatusLight / Sound

Navigation: ► Balance menu > ⚙ Settings > 🏠 Balance > \*🔊 Screen / StatusLight / Sound

Parameter	Description	Values
Screen brightness	Defines the brightness of the display.	20 %   40 %   60 %   80 %*   100 %
Sound volume	Defines the volume of the terminal sound.	Inactive   20 %   40 %   60 %*   80 %   100 %
Sound on key press	Defines if there is a sound when a key is pressed.	Active*   Inactive
Sound on info	Defines if there is a sound when an information appears on the screen.	Active*   Inactive
Sound on warning	Defines is there is a sound when a warning appears on the screen.	Active*   Inactive
Sound on error	Defines is there is a sound in case of an error.	Active*   Inactive

StatusLight	<p>Activates/deactivates the <b>StatusLight</b>.</p> <p><b>Active (without green light)</b>: All current status of the balance are monitored, the red/yellow lights will turn on if needed, but the green light will stay turned off.</p> <ul style="list-style-type: none"> <li>• <b>StatusLight</b> is red: Error. The balance must not be used until the error is corrected.</li> <li>• <b>StatusLight</b> is yellow: Warning. For example, the test manager has pushed a test to the balance or you are operating the balance between the date of the calibration reminder and the scheduled date of the next calibration. The balance can still be used.</li> <li>• <b>StatusLight</b> is green or off: Ok. No problems detected and the balance is ready to weigh.</li> </ul>	Active*   Active (without green light)   Inactive
StatusLight brightness	<p>Defines the brightness of the activated <b>StatusLight</b>.</p> <p>This setting is only available if <b>StatusLight</b> is set to <b>Active</b> or <b>Active (without green light)</b>.</p>	20 %   40 %   60 %*   80 %   100 %

\* Factory setting

## General

≡ Navigation: ► Balance menu > ⚙ Settings > ⚖ Balance > ⚙ General

Parameter	Description	Values
Balance ID	<p>Defines the ID of the balance. This name could be used to communicate with the balance over a network.</p> <p>No space or special characters are allowed.</p>	Text (0...22 characters)
Standby	<p>Defines if the balance automatically enters standby mode after not being used for a predefined <b>Wait time</b>.</p> <p>If <b>User management</b> is active, the user will be automatically logged out when the balance switches to standby mode.</p> <p>The standby mode can always be started manually by pressing .</p>	Active*   Inactive
Wait time	<p>Defines after how long the balance automatically switches to standby mode when not used.</p> <p>This setting is only available if <b>Standby</b> is set to <b>Active</b>.</p>	Numeric (10 minutes*   0...60 minutes)
Software update on system start-up	<p>With this option activated, software update can be performed from a USB storage device on startup.</p>	Active*   Inactive
Automatic export directory	<p>Defines the target directory for the automatic export.</p> <p>The possibility to export to <b>File server</b> is only available if a <b>File server</b> is configured (see [LabX / Services ► Page 86]).</p>	USB storage device*   File server
User management	<p>Activates/Deactivates the <b>User management</b>.</p>	Active   Inactive*

\* Factory setting



## 6.1.5.2 Modules / Dosing

Navigation: ► Balance menu > ⚙ Settings > 📄 Modules / Dosing

### Dosing module / Dosing head

Parameter	Description	Values
Dosing head label	Defines the template of the dosing head label to be printed, i.e., which data is included on the label and in which format. This section contains several settings that are described in the table <b>Dosing head label</b> below.	

### Dosing head label

Parameter	Description	Values
Copies	Defines how many copies of the label are printed.	Numeric
Used template	Chooses the label template.	Available labels are shown below.





### Field settings

The content of each label field can be defined individually.

Parameter	Description	Values
Label field 1	Defines which information appears in each label field. The number of label fields depends on the selected template.	Available entries depend on the method settings.

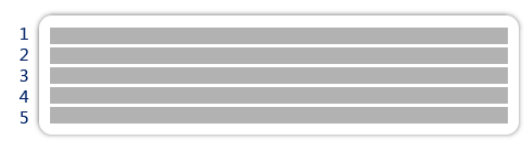
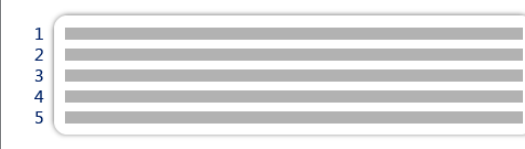
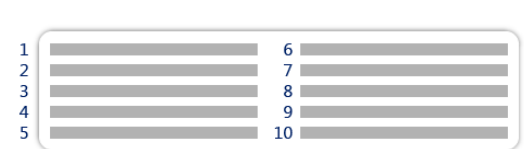
### Available labels

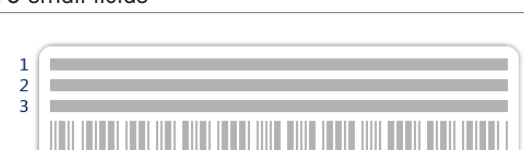
The following label layouts can be selected:

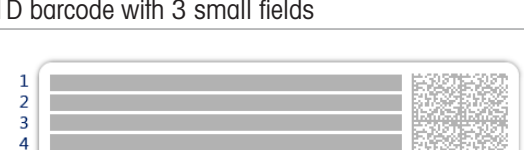
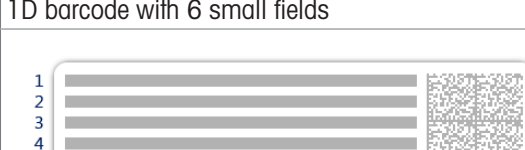
 <p>5 large fields</p>	 <p>5 small fields</p>
 <p>10 small fields</p>	 <p>1D barcode with 3 large fields</p>
 <p>1D barcode with 3 small fields</p>	 <p>1D barcode with 6 small fields</p>
 <p>2D barcode with 5 large fields</p>	 <p>2D barcode with 5 small fields</p>

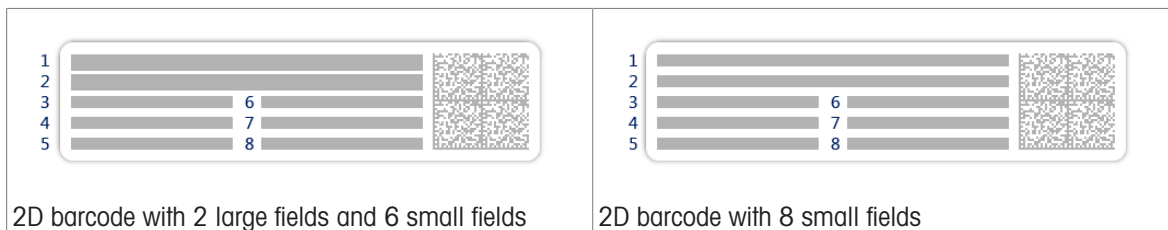

### 6.1.5.3 Interfaces

Navigation: ► Balance menu > Settings > Interfaces

The section **Interfaces** has the following subsection:

- Ethernet
- Bluetooth

#### Ethernet

The **Ethernet** interface allows to connect the balance to a network in order to:

- store weighing results as XML files on a share folder
- communicate remotely with the balance using the MT-SICS communication protocol or LabX

Navigation: ► Balance menu > Settings > Interfaces > Ethernet

Parameter	Description	Values
Host name	Defines the balance host name.	Text (1...22 characters)
MAC address	Information on the MAC address (Media Access Control) that is used to uniquely identify the balance in the network.	
Network configuration	<b>DHCP:</b> The settings of the Ethernet connection will be automatically set. <b>Manual:</b> The settings of the Ethernet connection must be set manually by the user.	DHCP*   Manual
IP address	If the IP is not to be automatically obtained, you can enter it here.	000.000.000.000... 255.255.255.255
Subnet mask	Defines the subnet mask that is used by the TCP/IP protocol to determine whether a host is on the local subnet or on a remote network.	000.000.000.000... 255.255.255.255
DNS server (primary)	Defines the address of the primary DNS (domain name system) server.	000.000.000.000... 255.255.255.255
DNS server (secondary)	Defines the address of the secondary DNS server.	000.000.000.000... 255.255.255.255
Default gateway	Defines the address of the default gateway that links the host's subnet to other networks.	000.000.000.000... 255.255.255.255

\* Factory setting

#### Bluetooth

Navigation: ► Balance menu > Settings > Interfaces > Bluetooth

##### Bluetooth identification

Parameter	Description	Values
Activation	With the option <b>Bluetooth</b> you have the possibility to communicate with a printer via Bluetooth.	Inactive*   Active

\* Factory setting

## 6.1.5.4 Devices / Printers

☰ **Navigation:** ▶ **Balance menu** > ⚙️ **Settings** > 🖨️ **Devices / Printers**

This section is divided into the following subsections:

- 🖨️ **Light barrier**
- 🖨️ **Printer**
- 📊 **Barcode reader**
- 📡 **RFID reader**
- 🌀 **ErgoSens**
- 🦶 **Foot switch**

### Light barrier

☰ **Navigation:** ▶ **Balance menu** > ⚙️ **Settings** > 🖨️ **Devices / Printers** > 🖨️ **Light barrier**

Once connected to a USB port of the balance, the device is automatically recognized. The settings can be consulted here.

### Printer

☰ **Navigation:** ▶ **Balance menu** > ⚙️ **Settings** > 🖨️ **Devices / Printers** > 🖨️ **Printer**

#### Printer settings

Parameter	Description	Values
Printer category	Defines the type of the printer. <b>Strip printer:</b> to print weighing results on strip paper <b>Label printer:</b> to print weighing results on labels	Strip printer   Label printer*
Device	Allows to activate or deactivate the device.	Activated*   Deactivated
Line end	Defines the line end character for printing. The values set here have to match the printer settings. This setting is only available for strip printers.	<CR> <LF>*   <CR>   <LF>
Character set	Defines the communication specific character code. The values set here have to match the printer settings. This setting is only available for strip printers.	ANSI/WIN   IBM/DOS   UTF8*

\* Factory setting

### Barcode reader

☰ **Navigation:** ▶ **Balance menu** > ⚙️ **Settings** > 📊 **Devices / Printers** > 📊 **Barcode reader**

Once connected to a USB port of the balance, the device is automatically recognized. The settings can be consulted here.

### RFID reader

☰ **Navigation:** ▶ **Balance menu** > ⚙️ **Settings** > 📡 **Devices / Printers** > 📡 **RFID reader**

Once connected to a USB port of the balance, the device is automatically recognized. The settings can be consulted here.

## ErgoSens

Navigation: ► Balance menu > ⚙ Settings > 🖨 Devices / Printers > 📶 ErgoSens

Parameter	Description	Values
Function	Defines which function is to be executed when triggering the device. If set to <b>Door</b> , the setting <b>Balance &gt; Doors &gt; Devices</b> needs to be specified.	None*   Door   Zero   Tare   Add result

\* Factory setting

## Foot switch

Navigation: ► Balance menu > ⚙ Settings > 🖨 Devices / Printers > 📶 Foot switch

Parameter	Description	Values
Function	Defines which function is to be executed when triggering the device. If set to <b>Door</b> , the setting <b>Balance &gt; Doors &gt; Devices</b> needs to be specified.	None*   Door   Zero   Tare   Add result

\* Factory setting

## See also

🔗 Printer ► Page 50

🔗 RFID reader ► Page 54

🔗 Foot switch and ErgoSens ► Page 55

### 6.1.5.5 LabX / Services

Several services are available to communicate with the balance: **LabX service**, **MT-SICS service**, or **Web service**. Note that only one service can be enabled at any given time.

To enable communication between LabX and instruments, the appropriate settings on the instruments must correspond with the settings in LabX. LabX synchronizes the date and time on the instruments with the LabX Server each time a connection is made and each time a task is started. When an instrument is connected, the user interface language on the connected instrument is changed to the language currently installed on the LabX installation.

Navigation: ► Balance menu > ⚙ Settings > 🌐 LabX / Services

Parameter	Description	Values
LabX service	<b>Inactive:</b> No connection to LabX will be established. <b>Network:</b> A network connection to LabX will be established on startup. The <b>Port</b> must be specified. <b>USB:</b> A USB connection to LabX will be established on startup.	Inactive*   Network   USB
MT-SICS service	<b>Inactive:</b> No MT-SICS port will be opened. <b>Network:</b> An MT-SICS network port will be opened on startup. The <b>Port</b> must be specified. <b>USB:</b> An MT-SICS USB port will be opened on startup.	Inactive*   Network   USB
Web service	If set to <b>Active</b> , a network port will be opened on startup. Use the menu <b>Web service configuration</b> to configure the service. The complete <b>Web service</b> documentation is available online: ▶ <a href="http://www.mt.com/labweighing-software-download">www.mt.com/labweighing-software-download</a> .	Inactive*   Active

File server	Allows to define a file server to import/export data. If set to <b>Active</b> , use the menu <b>File server configuration</b> to configure the server.	Active   Inactive*
-------------	---	--------------------

\* Factory setting

#### See also

- [LabX service](#) ▶ Page 57
- [MT-SICS service](#) ▶ Page 58
- [Web service](#) ▶ Page 59
- [Data management](#) ▶ Page 60

### 6.1.5.6 Printing the settings

☰ **Navigation:** ▶ **Balance menu** > ⚙️ **Settings**

When all the balance settings are configured, you can print the complete list to archive the information.

- To print the balance settings, tap 🖨️ **Print the settings**.
  - ➔ The complete balance settings are printed.

### 6.1.6 Maintenance

☰ **Navigation:** ▶ **Balance menu** > 🛠️ **Maintenance**

The option **Maintenance** only appears if the user has the appropriate user rights.

The section **Maintenance** is divided into the following subsections:



- 📄 **Import / Export**
- 📡 **Format RFID**
- 🔄 **Software update**
- ↺ **Reset**
- 🔧 **Service menu**

#### See also

- [Data management](#) ▶ Page 60
- [RFID reader](#) ▶ Page 54
- [Software update](#) ▶ Page 115
- [Resetting the balance](#) ▶ Page 68

#### 6.1.6.1 Service menu

☰ **Navigation:** ▶ **Balance menu** > 🛠️ **Maintenance** > 🔧 **Service menu**

Icon	Name	Description
	<b>Device errors</b>	Tap to display the code of an error. This error code can be useful in your communication with METTLER TOLEDO when troubleshooting your device. The icon depends on the severity of the error: critical error, warning, or information.  The icons of device errors only appear when an error with an error code is ongoing on the device.
		
		

Icon	Name	Description
	<b>Show adjustment state</b>	Tap to open information about: <ul style="list-style-type: none"> <li>• <b>Prescaler</b></li> <li>• <b>Temperature compensation</b></li> <li>• <b>Production linearization</b></li> <li>• <b>Standard calibration</b></li> <li>• <b>Production calibration</b></li> <li>• <b>User linearization</b></li> <li>• <b>User calibration</b></li> </ul>
	<b>Save support file</b>	Tap to save support file (all relevant information to an error) on a USB storage device to send it to a METTLER TOLEDO representative.
	<b>Import log configuration</b>	A log configuration file can be provided by METTLER TOLEDO to allow a more comprehensive collection of balance parameters to be stored in the support file. This is only used for troubleshooting purposes.  Tap to import the log configuration from a USB storage device so that the enhanced list of parameters can be exported and sent to a METTLER TOLEDO representative.

## 6.2 Weighing methods settings

For the balance model described in this manual, only the method **General weighing** is relevant.

### 6.2.1 Settings: method "General weighing"

In this section, the settings of the methods **General weighing** and **General weighing (itemized)** are described. Settings can be edited for a newly created method or an already existing method.

≡ Navigation: ▼ **Methods** > ☰ **Methods list** > ⚙ **my general weighing** > ✎ **Edit**

✎ Edit method - my general weighing

General	Method type	General weighing
ID format	Method name	my general weighing
Weighing	Comment	<i>Enter here</i>
Weighing item		
Automation	Lock method	<input type="checkbox"/>
Print / Export		

↶ Close
✓ Save

The settings of the method **General weighing** are grouped as follows:

- **General**
- **ID format**
- **Weighing**
- **Weighing item**, only available for the method **General weighing**
- **Weighing items**, only available for the method **General weighing (itemized)**
- **Automation**
- **Print / Export**

## See also

[Creating a method "General weighing" ▶ Page 37](#)

[Editing a method ▶ Page 38](#)

### 6.2.1.1 General

The **Method type** is defined in the wizard while creating the method and cannot be changed.

Parameter	Description	Values
Method name	Defines the name of the method.	Text (1...22 characters)
Comment	The method can be described with a comment.	Text (0...128 characters)
Lock method	Locks the method to prevent further editing.	Active   Inactive*

\* Factory setting

### 6.2.1.2 ID format

#### Task IDs

Parameter	Description	Values
Number of task IDs	Defines the number of task IDs. If the <b>Number of task IDs</b> is larger than 0, the settings <b>Task ID</b> , <b>Task description</b> and <b>Prefix/Default value</b> are available for every single task ID.	0   1*   2   3
Task ID 1	Defines the naming type of the task ID. <b>Manual with default:</b> The value of the task ID can be entered manually at method execution time. <b>Automatic timestamp:</b> The system provides a value created from a prefix with the current date and time appended.	Manual with default*   Automatic timestamp
Task description	Allows to define a label for each task ID field.	Text (0...32 characters)
Default value	Defines a default value for the task ID. The value of the task ID can be changed manually while executing the method. This setting is only available when the corresponding <b>Task ID</b> is set to <b>Manual with default</b> .	Text (0...32 characters)
Prefix	Defines a prefix for the task ID. This setting is only available is the corresponding <b>Task ID</b> is set to <b>Automatic timestamp</b> .	Text (0...32 characters)

\* Factory setting

#### Result IDs

Parameter	Description	Values
Number of result IDs	Defines the number of result IDs. If the <b>Number of result IDs</b> is larger than 0, the settings <b>Result ID</b> , <b>Result description</b> and <b>Prefix/Default value</b> are available for every single result ID.	0   1*   2   3
Result ID 1	Defines the naming type of the result ID. <b>Manual with default:</b> The value of the result ID can be entered manually at method execution time. <b>Automatic counter:</b> The system provides a value created from a <b>Prefix</b> to which is appended a unique number (counter).	Manual with default*   Automatic counter
Result description	Allows to define a label for each result ID.	Text (0...32 characters)

Default value	Defines a default value for the result ID. The value of the result ID can be changed manually while executing the method. This setting is only available when the corresponding <b>Result ID</b> is set to <b>Manual with default</b> .	Text (0...32 characters)
Prefix	Defines a prefix for the result ID. This setting is only available if the corresponding <b>Result ID</b> is set to <b>Automatic counter</b> .	Text (0...32 characters)

\* Factory setting

### 6.2.1.3 Weighing

Parameter	Description	Values
Show info weight	When set to <b>Active</b> , a secondary weight is displayed on the weighing screen.	Active   Inactive*
Info unit	Defines the unit of the <b>Info weight</b> . This setting is only available if <b>Show info weight</b> is set to <b>Active</b> .	The available units depend on the balance model.

\* Factory setting

#### Weighing settings

Parameter	Description	Values
Tolerance profile	A tolerance profile stores all the necessary balance settings needed for a certain weighing method. It is possible to create different tolerance profiles for different weighing methods.	Tolerance profiles are created by the user for specific balances and applications.
Weight capture mode	Defines the behavior when the button to add the result was tapped or the add result was triggered by the automatic weighing result creation. <b>Stable</b> : The system waits for a stable weight. <b>Immediate</b> : The system doesn't wait for a stable weight. The system waits for the defined amount of seconds ( <b>Weight capture delay</b> ). After the weight capture delay, the weight value from the weight stream is captured.	Stable*   Immediate
Weight capture delay	Defines the time in seconds the balance waits for capturing the weight after the button to add the result was tapped or the add result was triggered by the automatic weighing result creation. This setting is only available if <b>Weight capture mode</b> is set to <b>Immediate</b> .	Numeric (5 seconds*   0...60 seconds)

\* Factory setting



## Statistics

Parameter	Description	Values
Activate statistics	<p>If <b>Activate statistics</b> is set to <b>Active</b>, the following statistics will be calculated:</p> <p><b>Count:</b> Number of items used for the statistics</p> <p><b>Sum:</b> sum of all value (decimal places and unit according to the method settings)</p> <p><b>Minimum:</b> smallest value (decimal places and unit according to the method settings)</p> <p><b>Maximum:</b> largest value (decimal places and unit according to the method setting)</p> <p><b>Range:</b> difference between the largest and smallest values (decimal places and unit according to the method settings)</p> <p><b>Average:</b> The values are summed up and divided by the number of values, rounded to 1 digit more than the configured decimal places in the associated tolerance profile (unit according to the method settings).</p> <p><b>Standard deviation:</b> standard deviation rounded to 1 digit more than the configured decimal places in the associated tolerance profile (unit according to the method settings)</p> <p><b>Relative standard deviation:</b> relative standard deviation (rounded to 2 decimal places, in %)</p> <p>The statistical values are calculated and displayed as soon as a result is added or updated.</p>	Active   Inactive*

\* Factory setting

## Electrostatic

Parameter	Description	Values
Ionizer	Defines whether the ionizer is activated/deactivated.	Active   Inactive*

\* Factory setting

## See also

 [Creating a method "General weighing" ▶ Page 37](#)

### 6.2.1.4 Weighing item / Weighing items

A target weight with tolerance limits can be defined for the method. The method **General weighing** includes a single item in **Weighing item**, whereas several items can be defined for the method **General weighing (itemized)** in **Weighing items**.

Parameter	Description	Values
Sample ID	<p>Defines the name of the sample.</p> <p>This setting is only available for methods containing several weighing items (itemized).</p>	Text (0...32 characters)
Unit	Defines the unit of the weighing result.	The available units depend on the balance model.
Target weight	Defines the target weight. The target weight will be shown in the weighing-in aid of the balance (SmartTrac). When a target weight including tolerances is defined, the SmartTrac indicates if the current display weight is in tolerance or not.	Numeric
-Tolerance	<p>Defines the lower tolerance limit.</p> <p>This setting is only available if a <b>Target weight</b> is defined.</p>	Numeric

+Tolerance	Defines the upper tolerance limit. This setting is only available if a <b>Target weight</b> is defined.	Numeric
------------	--	---------

### See also

 [Creating a method "General weighing" ▶ Page 37](#)

## 6.2.1.5 Automation

Parameter	Description	Values
Barcode data target	<p>If a barcode reader is connected to the balance, this option defines how the data is to be processed.</p> <p><b>Keyboard Input:</b> The data is written in the currently open input window. If no input window is open, the data is ignored.</p> <p><b>Target weight value:</b> The barcode data is interpreted as a value for the target weight.</p> <p><b>Task ID 1:</b> The received barcode data is treated as identification text for this task ID.</p> <p><b>Result ID 1:</b> The received barcode data is treated as identification text for this result ID.</p> <p>The available items in the drop-down menu depend on the <b>Number of task IDs</b> and <b>Number of result IDs</b> specified for the method.</p> <p>Make sure that the characters of the scanned barcode are compatible with the format of the field where they should be inserted.</p>	Keyboard Input*   Target weight value   Task ID 1   Result ID 1   ...

\* Factory setting



### Automatic feeder support

This feature is not supported for the balance type described in this manual.

Parameter	Description	Values
Automatic feeder support	<p>Enables or disables the automatic feeder support.</p> <p>To use the automatic feeder support, the automatic feeder has to be connected to the balance by USB and has to be configured correctly.</p>	Active   Inactive*
Number of weighing items	Defines the number of items that the automatic feeder will deliver to the balance.	Numeric (20*   1...100)
Plausibility limits	<p>Defines the plausibility limit for measured values.</p> <p>The plausibility limit relates to the defined target weight.</p> <p>Example: With a plausibility limit of 30%, all weight values that are within <math>\pm 30\%</math> of the target weight are regarded as plausible and are transferred into the statistics. All other weight values are being ignored and excluded from the statistics.</p>	Numeric (30%*   0...100%)
Discharge feeder at the end	<p>Specifies if the automatic feeder is emptied of all objects after the task.</p> <p><b>Active:</b> The automatic feeder feeds at the configured discharge feed rate and stops 90 seconds after the last object has passed the light barrier.</p> <p><b>Inactive:</b> No automatic emptying.</p>	Active   Inactive*
Feed rate	Defines the rate at which the automatic feeder delivers the items to the balance.	Slow   Normal*   Fast   Very fast

\* Factory setting

## Weighing automation

Parameter	Description	Values
Automatic zero	<b>Active:</b> the balance is automatically zeroed when the weight falls below a predefined threshold. This setting is not available for approved balances.	Active   Inactive*
Automatic zero threshold	Defines the threshold of the <b>Automatic zero</b> . This setting is only available if <b>Automatic zero</b> is set to <b>Active</b> .	Numeric
Tare Mode	Defines the tare mode. <b>None:</b> No automatic tare. <b>Automatic tare:</b> The balance stores automatically the first stable weight as the tare weight. <b>Preset tare:</b> Allows you to enter manually a numerical entry of a fixed tare weight.	None*   Automatic tare   Preset tare
Automatic tare threshold	Defines the threshold of the option <b>Tare Mode</b> . This value defines the minimum weight that must be applied to the weighing pan so that it is automatically stored as the tare weight. If the weight is below the limits, it is not automatically transferred to the tare memory. Instead of entering the weight, the lightest tare container can be placed on the weighing pan and the button  subsequently pressed. The applied weight is directly taken over as a limit. This setting is only available if <b>Tare Mode</b> is set to <b>Automatic tare</b> .	Numeric
Preset tare value	Defines a weight value for the pretare function. Instead of entering the value, the respective tare container can be placed on the weighing pan and the button  subsequently pressed. The weight is directly taken over as pretare value. This setting is only available if <b>Tare Mode</b> is set to <b>Preset tare</b> .	Numeric
Automatic result	Automatically generates a weighing result after a threshold is reached. <b>None:</b> No automatic result will be generated. <b>With sample tare:</b> After a weight value that reached the threshold is being removed from the weighing pan, the balance is being tared. <b>Without sample tare:</b> After a weight value that reached the threshold is being removed from the weighing pan, the balance is not being tared. If <b>Automatic feeder support</b> is activated, the setting <b>Automatic result</b> is automatically set to <b>Without sample tare</b> and cannot be edited.	None   With sample tare*   Without sample tare
Automatic result threshold	Defines the threshold of the <b>Automatic result</b> . The result is automatically added to the <b>Results list</b> only if the weight of the sample is larger than the defined threshold. This setting is only available if <b>Automatic result</b> is set to <b>Active</b> .	Numeric

Weight trigger	<p>Defines the behaviour of the option <b>Automatic result threshold</b>.</p> <p><b>Exceeding:</b> The weighing result is generated when the weight exceeds the defined threshold.</p> <p><b>Falling below:</b> The weighing result is generated when the weight falls below the defined threshold.</p> <p>This setting is only available if <b>Automatic result</b> is set to <b>Without sample tare</b>.</p> <p>If <b>Automatic feeder support</b> is activated, the setting <b>Weight trigger</b> is automatically set to <b>Exceeding</b> and cannot be edited.</p>	Exceeding*   Falling below
Automatic tare after result	If set to <b>Active</b> , the balance is automatically tared when a result is added to the <b>Results list</b> .	Active   Inactive*
Automatic task completion	<p><b>Active:</b> the balance automatically completes a running task after the result of the last weighing item has been added to the <b>Results list</b>.</p> <p>This setting is only available if the method is using multiple weighing items.</p>	Active   Inactive*

\* Factory setting

#### See also

 [Creating a method "General weighing" ▶ Page 37](#)

### 6.2.1.6 Print / Export

Parameter	Description	Values
Strip printout and data export	<p>Defines the content of the printout and/or export, as well as which printing/exporting actions are performed automatically when the task is complete.</p> <p>This section contains several settings that are described in the table <b>Strip printout and data export</b> below.</p>	
Label printout for task	<p>Defines the template of the task label to be printed, i.e., which data is included on the label and in which format.</p> <p>This section contains several settings that are described in the table <b>Label printout for task</b> below.</p>	
Label printout for weighing item	<p>Defines the template of the weighing item label to be printed, i.e., which data is included on the label and in which format.</p> <p>This section contains several settings that are described in the table <b>Label printout for weighing item</b> below.</p>	
Label cutting	<p>Defines if the labels should be cut after printing.</p> <p><b>Per label:</b> Each label is cut once printed.</p> <p><b>Per task:</b> The labels are cut when the task is complete.</p> <p>This setting is only relevant if the connected label printer can cut labels.</p>	Off*   Per label   Per task

\* Factory setting

## 6.2.1.6.1 Strip printout and data export

### Automatic data output



Parameter	Description	Values
Strip printer	Activates/Deactivates automatic printing of the <b>Results list</b> on a strip printer when the <b>Complete</b> button is tapped. The data to be transmitted to the printer can be defined in the section <b>Template settings</b> .	Active   Inactive*
Results export	Activates/Deactivates the automatic data export to a file server or USB storage device when the <b>Complete</b> button is tapped.	Active   Inactive*
Weight value	Activates/Deactivates the option to automatically send the weighing value over USB or Ethernet when tapping <b>Add result</b> .	Active   Inactive*

\* Factory setting

### Strip printout template

This menu item can be used to define which information is printed by the strip printer.

Each individual parameter can be set to **Inactive** or **Active** via the corresponding check box. To enable or disable all parameters at once, proceed as follows:

- To disable all check boxes at once, tap  **Deselect all**.
  - ➔ All parameters are set to **Inactive**.
- To enable all check boxes at once, tap  **Select all**.
  - ➔ All parameters are set to **Active**.

### Template settings

Parameter	Description	Values
Header and Footer	Defines the header and/or footer to be printed.	Title   Title text   Date/time   User   Signature   Separating lines   Group titles
Balance information	Defines which information about the balance is printed.	Balance type   Balance ID   Balance serial number   Software version
Quality information	Defines which quality information is printed.	Tolerance profile   Adjustment date/time   Routine test name   Routine test last execution date   Routine test result   GWP Approved state   Level state   MinWeigh state
Task information	Defines which information about the task is printed.	Method name   Method comment   Task IDs   Custom unit settings   Automatic result settings   Count   Sum   Average   Minimum   Maximum   Range   Standard deviation   Relative standard deviation

Weighing item information	Defines which information about the weighing items is printed.	Show excluded weighing items   Result state   Result IDs   GWP Approved state   Electrostatic charge   Level state   MinWeigh state   Tolerance state   Target and tolerances
Result detail information	Defines which information related to the result of the measurement is printed.	Weight   Tare weight   Gross weight   Info weight   Date/time   Stability

### 6.2.1.6.2 Label printout for task

Parameter	Description	Values
Automatic label printout for task	When set to <b>Active</b> , the task label is automatically printed when tapping <b>Complete</b> .	Active   Inactive*
Copies	Defines how many copies of the label are printed.	Numeric
Used template	Chooses the label template.	Available labels are shown below.

\* Factory setting

#### Field settings

The content of each label field can be defined individually.

Parameter	Description	Values
Label field 1	Defines which information appears in each label field. The number of label fields depends on the selected template.	Available entries depend on the method settings.

#### Barcode settings

The content of each barcode field can be defined individually. This section is only available when the selected **Used template** contains at least one 2D code.

Parameter	Description	Values
Delimiter	Defines the delimiter between the barcode entries. This setting is only available when the selected <b>Used template</b> contains several 2D codes.	TAB*   Form feed   Carriage return   Space   User defined
Barcode field 1	Defines which information appears in each barcode. The number of the barcode fields depends on the selected template.	Available entries depend on the method settings.

\* Factory setting

### 6.2.1.6.3 Label printout for weighing item

Parameter	Description	Values
Automatic label printout for weighing item	When set to <b>Active</b> , the weighing item label is automatically printed when tapping <b>Add result</b> .	Active   Inactive*
Copies	Defines how many copies of the label are printed.	Numeric
Used template	Chooses the label template.	Available labels are shown below.

\* Factory setting

## Field settings

The content of each label field can be defined individually.

Parameter	Description	Values
Label field 1	Defines which information appears in each label field. The number of label fields depends on the selected template.	Available entries depend on the method settings.

## Barcode settings





The content of each barcode field can be defined individually. This section is only available when the selected **Used template** contains at least one 2D code.

Parameter	Description	Values
Delimiter	Defines the delimiter between the barcode entries. This setting is only available when the selected <b>Used template</b> contains several 2D codes.	TAB*   Form feed   Carriage return   Space   User defined
Barcode field 1	Defines which information appears in each barcode. The number of the barcode fields depends on the selected template.	Available entries depend on the method settings.

\* Factory setting

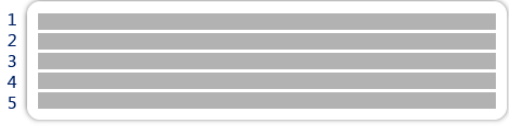
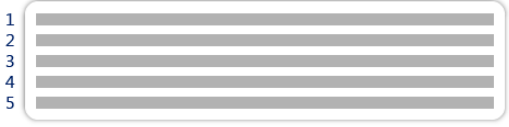
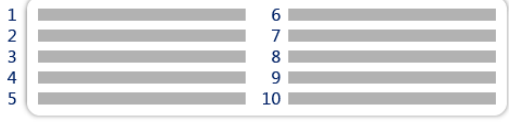
### 6.2.1.6.4 Available labels

The following label layouts can be selected:

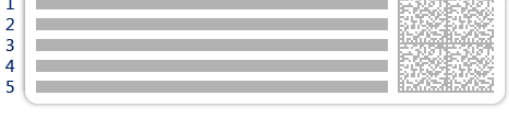
 <p>1 2 3 4 5</p> <p>5 large fields</p>	 <p>1 2 3 4 5</p> <p>5 small fields</p>
 <p>1 2 3 4 5</p> <p>6 7 8 9 10</p> <p>10 small fields</p>	 <p>1 2 3</p> <p>1D barcode with 3 large fields</p>
 <p>1 2 3</p> <p>1D barcode with 3 small fields</p>	 <p>1 2 3</p> <p>4 5 6</p> <p>1D barcode with 6 small fields</p>
 <p>1 2 3 4 5</p> <p>2D barcode with 5 large fields</p>	 <p>1 2 3 4 5</p> <p>2D barcode with 5 small fields</p>

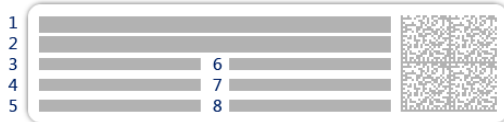

2D barcode with 2 large fields and 6 small fields

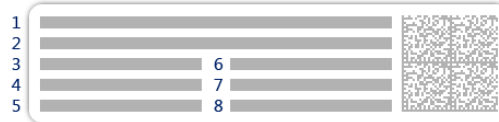

2D barcode with 8 small fields



## 6.3 Test weights settings

### 6.3.1 Settings: individual test weight

Navigation: ▼ Methods > Tests > Test weights > my weight 1 > Edit

Parameter	Description	Values
Test weight name	Defines the name of the test weight.	Text (1...22 characters)
Test weight ID	Defines the test weight ID.	Text (1...22 characters)
Nominal weight	Defines the approximate, rounded value of the <b>Actual weight</b> .	Numeric
Weight class	Defines the weight class according to OIML or ASTM. Alternatively, a customized tolerance class can be created with <b>Own</b> .	E1   E2   F1   F2   M1   M2   M3   ASTM000   ASTM00   ASTM0   ASTM0   ASTM1   ASTM2   ASTM3   ASTM4   ASTM5   ASTM6   ASTM7   Own*
Actual weight	Defines the actual weight. The actual weight is a specific weight with a specific Conventional Mass Value (CMV) from the weight calibration certificate.	Numeric
Next calibration date	Defines the next date for calibration.	Date
Certificate	If the certificate of the test weight is available, set to <b>Active</b> and fill in the additional information related to the certificate (see below).	Active   Inactive*
Certificate ID	Defines the certificate ID. This setting is only available if <b>Certificate ID</b> is set to <b>Active</b> .	Text (1...22 characters)
Certificate date	Defines the certificate date. This setting is only available if <b>Certificate ID</b> is set to <b>Active</b> .	Date
Weight set ID	Defines the weight set ID.	Text (1...22 characters)

\* Factory setting

### 6.3.2 Settings: combined test weight

Navigation: ▼ Methods > Tests > Test weights > my weight 1+2 > Edit

Parameter	Description	Values
Test weight name	Defines the name of the test weight.	Text (1...22 characters)
Nominal weight	Shows the sum of the nominal weights of all the individual weights included in this combined weight.	Numeric
Minimum weight class	Defines the minimum weight class according to OIML or ASTM. The customized tolerance class <b>Own</b> can also be selected. When choosing the weights that compose the combined weight, only the individual weights with a class better or equal to the selected <b>Minimum weight class</b> are shown.	E1   E2   F1   F2   M1   M2   M3   ASTM000   ASTM00   ASTM0   ASTM0   ASTM1   ASTM2   ASTM3   ASTM4   ASTM5   ASTM6   ASTM7   Own*
Weights	Displays a list of the available individual test weights. A total of two or three individual test weights can be selected. Only the individual weights with a class better or equal to the selected <b>Minimum weight class</b> are shown.	List of individual test weights

\* Factory setting

## 6.4 Tests settings

### 6.4.1 Settings: Repeatability test

Navigation: ▼ Methods > 📄 Tests > 📄 my repeatability test > ✎ Edit

#### 1. Name and type

Parameter	Description	Values
Test type	The test type has been pre-defined and cannot be changed in this menu.	Available test types
Name	Defines the name of the test.	Text (1...22 characters)
Test activated	Enables/disables the test.	Active*   Inactive
Show preparation instructions	If activated, a predefined preparatory instruction is displayed in the test sequence.	Active*   Inactive
Automatic print	When activated, the test results are immediately printed on the enabled strip printer after the test result has been calculated.	Active   Inactive*

\* Factory setting

#### 2. Test specification

Parameter	Description	Values
Result calculation	Select whether the nominal weight or the conventional mass value (CMV) is used for the result calculation. <b>On nominal weight:</b> Nominal value of a weight with a specific weight class. <b>On actual weight (CMV):</b> Conventional mass value (CMV) of a weight from the weight calibration certificate.	On nominal weight*   On actual weight (CMV)
Number of repetitions	Defines the number of weight measurements of a series.	Numeric (10*   2...15)

\* Factory setting

#### Tare

This section only appears when **Test type** is set to **Repeatab. - Tare - 1 TP**.

Parameter	Description	Values
Tare name	Defines a name for the tare weight.	Text (1...22 characters)
Minimum tare weight	Defines the minimum weight for the tare container. The test is only continued if a tare container with at least this weight is placed on the balance.	Numeric

\* Factory setting

#### Test point

Parameter	Description	Values
Nominal weight	Defines the nominal value of the weight that will be used for the test.	Numeric
Weight class	Defines the weight class according to OIML or ASTM. Alternatively, a customized tolerance class can be created with <b>Own</b> .	E1   E2   F1   F2   M1   M2   M3   ASTM000   ASTM00   ASTM0   ASTM1   ASTM2   ASTM3   ASTM4   ASTM5   ASTM6   ASTM7   Own*

\* Factory setting

## Test limits

Parameter	Description	Values
Control limit	Defines the error tolerance of a process with respect to its set value. Exceeding the <b>Control limit</b> is a violation of quality requirements and therefore requires a correction of the process. The minimum value is 40% of the balance readability. Result if the <b>Control limit</b> is exceeded: The test failed, the balance is out of specification.	Numeric
Warning limit	Defines the upper or lower limit that, if exceeded or not reached, makes more stringent process monitoring necessary. The <b>Warning limit</b> must be smaller than the <b>Control limit</b> . Result if the <b>Warning limit</b> is exceeded: The test is passed, but the difference is higher than expected.	Numeric

### 3. Test weights

A configured test weight can be selected. For information on test weights definition and settings, see Test weights and [Test weights settings ▶ Page 99].

### 4. Error management

Parameter	Description	Values
Block balance	Defines the behavior of the balance if a test has failed. <b>Active:</b> The balance will be blocked after a specified number of failed tests. In this case, the balance cannot be used anymore until a user with the appropriate right unblocks the balance. <b>Inactive:</b> Blocking is not activated.	Active   Inactive*
Allowed number of retries	Defines the maximum allowed retries until the balance will be blocked. This setting is only available if <b>Block balance</b> is set to <b>Active</b> .	Numeric (3*   0...9)

\* Factory setting

### 5. Test planning

Parameter	Description	Values
Planning type	Specifies the schedule for the test to be performed. <b>Manually:</b> The test is performed manually. <b>Daily:</b> A task is generated every day at the specified time. <b>Weekly:</b> A task is generated at least once a week. Additional days can be selected if required. <b>Monthly:</b> A task is generated every month at the specified day and time. <b>Quarterly:</b> A task is generated every three months at the specified time. <b>Annually:</b> A task is generated once a year at the specified time.	Manually*   Daily   Weekly   Monthly   Quarterly   Annually
Start time	Defines the time when the test is due. This setting is only available if <b>Planning type</b> is not set to <b>Manually</b> .	Time

\* Factory setting

## Notification

This section does not appear when **Planning type** is set to **Manually**.

Parameter	Description	Values
(x) hours before test	Defines the number of hours before a notification informs about the upcoming planned test.	Different values depending on the selected frequency (Planning type).
Notification every (x) hours	Defines the time interval before the next notification is issued.	Different values depending on the selected frequency (Planning type).

## Preferred days

This section only appears when **Planning type** is set to **Weekly**.

Parameter	Description	Values
Preferred days	Defines the preferred weekday for the execution of the test.	Monday*   Tuesday*   Wednesday*   Thursday*   Friday*   Saturday   Sunday

\* Factory setting

## Preferred day for execution

This section only appears when **Planning type** is set to **Monthly**.

Parameter	Description	Values
Day of the week	Defines the preferred day for execution of the test. If <b>None</b> is selected, the test will be scheduled for a month after the last execution.	None*   Monday   Tuesday   Wednesday   Thursday   Friday   Saturday   Sunday
Week of the month	Defines on which week of the month the test is performed. This setting is only available if <b>Day of the week</b> is not set to <b>None</b> .	First*   Second   Third   Fourth

\* Factory setting

## 6. Printing

Parameter	Description	Values
Header and Footer	Defines the header and/or footer to be printed.	Title   Title text   Date/ time   User   Signature   Separating lines   Group titles
Balance information	Defines which information about the balance is printed.	Balance type   Balance ID   Balance serial number   Software version
Test summary	Defines which information about the test summary is printed.	Test type   Test name   Test result   Standard deviation
Test details	Defines which test details are printed.	Test trigger   Leveling at start   Temperature   Preparation instructions   Test start (date / time)   Test end (date / time)   User name

Tare specification	Defines which information about the tare specification is printed. This section is only available for tests using a tare weight.	Tare name   Min. tare weight
Test weight	Defines which information about the test weight is printed.	Test weight ID   Weight class   Nominal weight   Actual weight   Weight set ID   Certificate ID   Certificate date   Next calibration date   Weight type   Minimum weight class   Used nominal weights   Used actual weights
Test limits	Defines which information about the test limits is printed.	Warning limit   Control limit
Measurements / Results	Defines which information about the measurements and the results is printed.	Weight   State   Level state   Zero / Tare

#### See also

[Defining an individual test weight](#) ▶ Page 40

[Creating a new test](#) ▶ Page 42

## 6.4.2 Settings: Sensitivity test

Navigation: ▼ Methods > Tests > my sensitivity test > Edit

### 1. Name and type

Parameter	Description	Values
Test type	The test type has been pre-defined and cannot be changed in this menu.	Available test types
Name	Defines the name of the test.	Text (1...22 characters)
Test activated	Enables/disables the test.	Active*   Inactive
Show preparation instructions	If activated, a predefined preparatory instruction is displayed in the test sequence.	Active*   Inactive
Automatic print	When activated, the test results are immediately printed on the enabled strip printer after the test result has been calculated.	Active   Inactive*

\* Factory setting

### 2. Test specification

Parameter	Description	Values
Result calculation	Select whether the nominal weight or the conventional mass value (CMV) is used for the result calculation. <b>On nominal weight:</b> Nominal value of a weight with a specific weight class. <b>On actual weight (CMV):</b> Conventional mass value (CMV) of a weight from the weight calibration certificate.	On nominal weight*   On actual weight (CMV)

\* Factory setting

#### Tare

This section only appears when the option **Test type** is set to **Sensitivity - Tare - 1 TP** or **Sensitivity - Tare - 2 TP**.

Parameter	Description	Values
Tare name	Defines a name for the tare weight.	Text (1...22 characters)

Minimum tare weight	Defines the minimum weight for the tare container. The test is only continued if a tare container with at least this weight is placed on the balance.	Numeric
---------------------	---	---------

### Test point

Depending on the selected test, the following options can be defined for one or two test points:

Parameter	Description	Values
Nominal weight	Defines the nominal value of the weight that will be used for the test.	Numeric
Weight class	Defines the weight class according to OIML or ASTM. Alternatively, a customized tolerance class can be created with <b>Own</b> .	E1   E2   F1   F2   M1   M2   M3   ASTM000   ASTM00   ASTM0   ASTM0   ASTM1   ASTM2   ASTM3   ASTM4   ASTM5   ASTM6   ASTM7   Own*
Control limit	Defines the error tolerance of a process with respect to its set value. Exceeding the <b>Control limit</b> is a violation of quality requirements and therefore requires a correction of the process. Result if the <b>Control limit</b> is exceeded: The test failed, the balance is out of specification.	Numeric
Warning limit	Defines the upper or lower limit that, if exceeded or not reached, makes more stringent process monitoring necessary. The <b>Warning limit</b> must be smaller than the <b>Control limit</b> . Result if the <b>Warning limit</b> is exceeded: The test is passed, but the difference is higher than expected.	Numeric

\* Factory setting

### 3. Test weights

A configured test weight can be selected. For information on test weights definition and settings, see Test weights and [Test weights settings ▶ Page 99].

### 4. Error management

Parameter	Description	Values
Block balance	Defines the behavior of the balance if a test has failed. <b>Active:</b> The balance will be blocked after a specified number of failed tests. In this case, the balance cannot be used anymore until a user with the appropriate right unblocks the balance. <b>Inactive:</b> Blocking is not activated.	Active   Inactive*
Allowed number of retries	Defines the maximum allowed retries until the balance will be blocked. This setting is only available if <b>Block balance</b> is set to <b>Active</b> .	Numeric (3*   0...9)

\* Factory setting

## 5. Test planning

Parameter	Description	Values
Planning type	Specifies the schedule for the test to be performed. <b>Manually:</b> The test is performed manually. <b>Daily:</b> A task is generated every day at the specified time. <b>Weekly:</b> A task is generated at least once a week. Additional days can be selected if required. <b>Monthly:</b> A task is generated every month at the specified day and time. <b>Quarterly:</b> A task is generated every three months at the specified time. <b>Annually:</b> A task is generated once a year at the specified time.	Manually*   Daily   Weekly   Monthly   Quarterly   Annually
Start time	Defines the time when the test is due. This setting is only available if <b>Planning type</b> is not set to <b>Manually</b> .	Time

\* Factory setting

### Notification

This section does not appear when **Planning type** is set to **Manually**.

Parameter	Description	Values
(x) hours before test	Defines the number of hours before a notification informs about the upcoming planned test.	Different values depending on the selected frequency (Planning type).
Notification every (x) hours	Defines the time interval before the next notification is issued.	Different values depending on the selected frequency (Planning type).

### Preferred days

This section only appears when **Planning type** is set to **Weekly**.

Parameter	Description	Values
Preferred days	Defines the preferred weekday for the execution of the test.	Monday*   Tuesday*   Wednesday*   Thursday*   Friday*   Saturday   Sunday

\* Factory setting

### Preferred day for execution

This section only appears when **Planning type** is set to **Monthly**.

Parameter	Description	Values
Day of the week	Defines the preferred day for execution of the test. If <b>None</b> is selected, the test will be scheduled for a month after the last execution.	None*   Monday   Tuesday   Wednesday   Thursday   Friday   Saturday   Sunday
Week of the month	Defines on which week of the month the test is performed. This setting is only available if <b>Day of the week</b> is not set to <b>None</b> .	First*   Second   Third   Fourth

\* Factory setting

## 6. Printing

Parameter	Description	Values
Header and Footer	Defines the header and/or footer to be printed.	Title   Title text   Date/time   User   Signature   Separating lines   Group titles
Balance information	Defines which information about the balance is printed.	Balance type   Balance ID   Balance serial number   Software version
Test summary	Defines which information about the test summary is printed.	Test type   Test name   Test result
Test details	Defines which test details are printed.	Test trigger   Leveling at start   Temperature   Preparation instructions   Test start (date / time)   Test end (date / time)   User name
Tare specification	Defines which information about the tare specification is printed. This section is only available for tests using a tare weight.	Tare name   Min. tare weight
Test weight	Defines which information about the test weight is printed.	Test weight ID   Weight class   Nominal weight   Actual weight   Weight set ID   Certificate ID   Certificate date   Next calibration date   Weight type   Minimum weight class   Used nominal weights   Used actual weights
Test limits	Defines which information about the test limits is printed.	Warning limit   Control limit
Measurements / Results	Defines which information about the measurements and the results is printed.	Weight   Deviation   State   Level state   Zero / Tare

### See also

- [Defining an individual test weight ▶ Page 40](#)
- [Creating a new test ▶ Page 42](#)

## 6.5 Adjustments settings

Navigation: ▼ Methods > ⚙ Adjustments > ⚙ Internal adjustment > ✎ Edit

### 1. Strategy

Parameter	Description	Values
Strategy	Defines the type of adjustment to be performed. When <b>Strategy</b> is set to <b>No adjustment</b> or <b>External adjustment</b> , no other settings are available. For approved balances, this setting is set to <b>Internal adjustment</b> and cannot be edited.	Internal adjustment*   External adjustment   No adjustment



Automatic print	When activated, the adjustment results are immediately printed on the enabled strip printer after the result has been calculated.	Active   Inactive*
-----------------	---	--------------------

\* Factory setting

## 2. Specification

Parameter	Description	Values
"As found" test	At the start of the adjustment sequence, an internal sensitivity test is automatically performed to evaluate the current status. The test results are displayed and recorded.	Active   Inactive*
"As left" test	When the adjustment is complete, an internal sensitivity test is automatically performed. The test results are displayed and recorded.	Active   Inactive*

\* Factory setting

## Limits

These settings only appear when one of the options "**As found**" test or "**As left**" test is activated.

Parameter	Description	Values
Control limit	Defines the error tolerance of a process with respect to its set value. Exceeding the <b>Control limit</b> is a violation of quality requirements and therefore requires a correction of the process. Result if the <b>Control limit</b> is exceeded: The adjustment failed, the balance is out of specification.	Numeric (0.1%*   0.001...100%)
Warning limit	Defines the upper or lower limit that, if exceeded or not reached, makes more stringent process monitoring necessary. The <b>Warning limit</b> must be smaller than the <b>Control limit</b> . Result if the <b>Warning limit</b> is exceeded: The adjustment is passed, but the difference is higher than expected.	Numeric (0.001...100%)

\* Factory setting

## 3. Error management

Parameter	Description	Values
Block balance	Defines the behavior of the balance if the adjustment has failed. <b>Active:</b> The balance will be blocked after the adjustment has failed. In this case, the balance can not be used anymore until a user with the appropriate right unblocks the balance. <b>Inactive:</b> The balance will not be blocked.	Active   Inactive*

\* Factory setting

## 4. Planning

Parameter	Description	Values
Start after leveling	Defines if the internal adjustment starts after leveling.	Active   Inactive*
Start after temperature change	Defines if the internal adjustment starts automatically after a temperature change of 1°C. For approved balances, this setting is set to <b>Internal adjustment</b> and cannot be edited. This restriction does not apply to balances of type /AC.	Active   Inactive*
Schedule	Defines when the adjustment is being performed. It is possible to define between one and three start times per day. It can also be defined on which day(s) the adjustment is being performed.	Inactive   1 start time   2 start times*   3 start times
Start time 1	Defines the start time for the execution of the task. The number of start times to be defined is specified by <b>Schedule</b> .	Time

Preferred days	Defines the days for the scheduled adjustments. This setting is only available if <b>Schedule</b> is not set to <b>Inactive</b> .	Monday   Tuesday   Wednesday   Thursday   Friday   Saturday   Sunday
----------------	--	--

\* Factory setting

## 5. Printing

Parameter	Description	Values
Header and Footer	Defines the header and/or footer to be printed.	Title   Title text   Date/time   User   Signature   Separating lines   Group titles
Balance information	Defines which information about the balance is printed.	Balance type   Balance ID   Balance serial number   Software version
Adjustment summary	Defines which information about the adjustment summary is printed.	Adjustment type   Adjustment status   Balance adjusted
Adjustment details	Defines which adjustment details are printed.	Trigger   Cell temperature   Level state   Date/time   User name
Adjustment weight	Defines which information about the adjustment weight is printed. This section is only available if an external weight is used for the adjustment.	Test weight ID   Weight class   Nominal weight   Actual weight   Weight set ID   Certificate ID   Certificate date   Next calibration date   Weight type   Minimum weight class   Used nominal weights   Used actual weights
Adjustment limits	Defines which information about the adjustment limits is printed. This section is only available for internal adjustments.	Warning limit   Control limit
Measurements / Results	Defines which information about the measurements and the results is printed. The settings available in this section depends on the adjustment strategy.	Correction   Test deviation "as found"   Test deviation "as left"   Test result "as found"   Test result "as left"

### See also

- [🔗 Defining an individual test weight ▶ Page 40](#)
- [🔗 Editing an "Internal adjustment" ▶ Page 48](#)
- [🔗 Editing an "External adjustment" ▶ Page 49](#)

## 7 Maintenance

To guarantee the functionality of the balance and the accuracy of the weighing results, a number of maintenance actions must be performed by the user.

The appropriate maintenance interval depends on your standard operating procedure (SOP).

### 7.1 Maintenance tasks

Maintenance action	Recommended interval	Remarks
Performing an internal adjustment	<ul style="list-style-type: none"><li>Daily</li><li>After cleaning</li><li>After leveling</li><li>After changing the location</li></ul>	see "Adjustments"
Performing routine tests (repeatability test, sensitivity test). METTLER TOLEDO recommends to at least perform a sensitivity test.	<ul style="list-style-type: none"><li>After cleaning</li><li>After assembling the balance</li><li>After a software update</li><li>Depending on your internal regulations (SOP)</li></ul>	see "Tests"
Emptying the containers	<ul style="list-style-type: none"><li>Depending on the frequency of usage of the instrument</li><li>Depending on your internal regulations (SOP)</li></ul>	see "Emptying the containers"
Cleaning	<ul style="list-style-type: none"><li>After every use</li><li>Depending on the degree of pollution</li><li>Depending on your internal regulations (SOP)</li></ul>	see "Cleaning"
Updating the software	<ul style="list-style-type: none"><li>Depending on your internal regulations (SOP).</li><li>After a new software release.</li></ul>	see "Software update"

#### See also

- [Adjustments](#) ▶ Page 48
- [Tests](#) ▶ Page 41
- [Emptying the containers](#) ▶ Page 110
- [Cleaning](#) ▶ Page 112
- [Software update](#) ▶ Page 115

## 7.2 Emptying the containers

### 7.2.1 Assembling the pump



#### **WARNING**

##### **Death or serious injury due to electric shock**

Contact with parts that carry a live current can lead to death or injury.

- 1 Only use the METTLER TOLEDO power cable and AC/DC adapter designed for your instrument.
- 2 Connect the power cable to a grounded power outlet.
- 3 Keep all electrical cables and connections away from liquids and moisture.
- 4 Check the cables and the power plug for damage and replace them if damaged.

During normal usage, the pipetting tanks and the evaporation trap recesses contain water. The pump serves to remove the water in a safe and efficient manner, without having to disassemble the instrument. The inlet tubing has a metallic tube attached for easier handling. The outlet tubing serves to dispose of the aspirated liquid.

- 1 Install the cables in such a way that they cannot be damaged or interfere with operation.
- 2 Insert the plug of the AC/DC adapter (1) into the power socket.
- 3 Secure the plug by firmly tightening the knurled nut.
- 4 Insert the plug of the power cable into a grounded power outlet that is easily accessible.
- 5 Connect the tubing with the metallic tube (2) to the nozzle IN (3).
- 6 Connect the other tubing to the nozzle OUT (4).
- 7 Place the free end of the tubing into a container suitable for liquid waste (5).

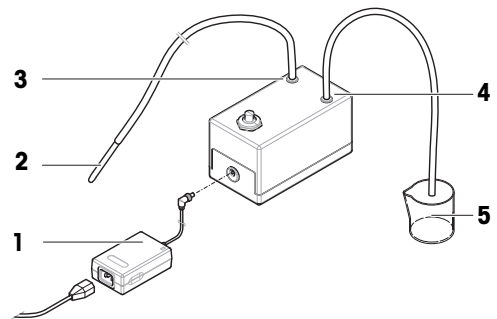

### 7.2.2 Emptying the pipetting container

The pipetting container must be regularly emptied to prevent an overflow.



#### **NOTICE**

##### **Damage to the pump due to inappropriate handling**

If the pump is switched on when it is not in use, it can get damaged.

- Switch off the pump when it is not in use.

- The pump is assembled.
  - The outlet tubing is placed in a container suitable for liquid waste.
- 1 Activate the light barrier (1), or press  $\updownarrow$ .
    - ➔ The evaporation trap door (2) opens.
  - 2 Introduce the metallic tube (3) into the pipetting container (4).
  - 3 Switch on the pump (5).
    - ➔ The liquid is pumped out and collected in the container for liquid waste.
  - 4 Switch off the pump (5).
  - 5 Reassemble the balance.
    - ➔ The balance is ready to be used.

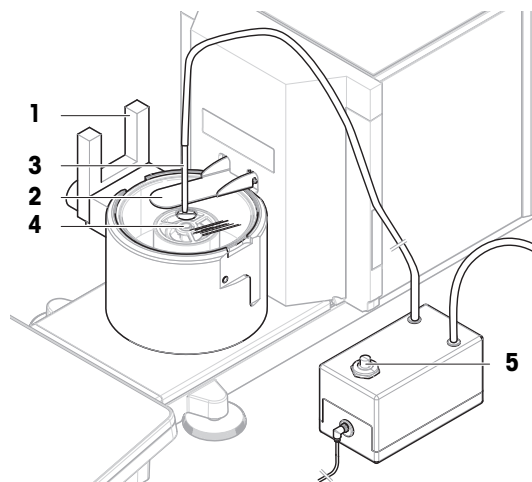

#### See also

[Assembling the pump](#) ▶ Page 110

### 7.2.3 Emptying the evaporation trap container



#### NOTICE

##### Damage to the pump due to inappropriate handling

If the pump is switched on when it is not in use, it can get damaged.

- Switch off the pump when it is not in use.

- The pump is assembled.
  - The outlet tubing is placed in a container suitable for liquid waste.
- 1 Remove the evaporation trap door (1).
  - 2 Carefully remove the evaporation trap cover (2).

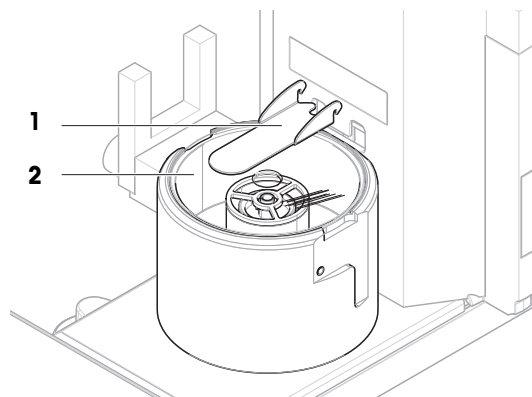

- 3 Introduce the metallic tube (3) into the evaporation trap container (4).
- 4 Switch on the pump (5).
  - ➔ The liquid is pumped out and collected in the container for liquid waste.
- 5 If required, use the pump to empty the pipetting container (6), see [Emptying the pipetting container ▶ Page 110].
- 6 Switch off the pump (5).
- 7 Alternatively, remove the evaporation trap container (4) to empty it.
- 8 Reassemble the balance.

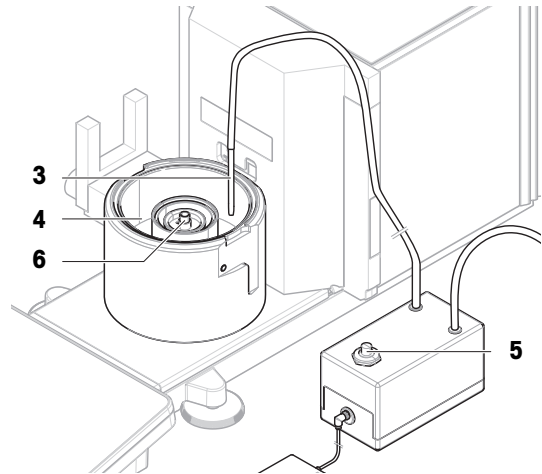

**See also**

🔗 Assembling the pump ▶ Page 110

## 7.3 Cleaning

### 7.3.1 Disassembling for cleaning

- The containers are empty, see [Emptying the containers ▶ Page 110].
  - The balance is switched off, see [Switching off the balance ▶ Page 31].
- 1 Remove the fixing screw (1) and put the light barrier (2) aside.
  - 2 Remove the evaporation trap door (3).
  - 3 Carefully remove the evaporation trap cover (4).

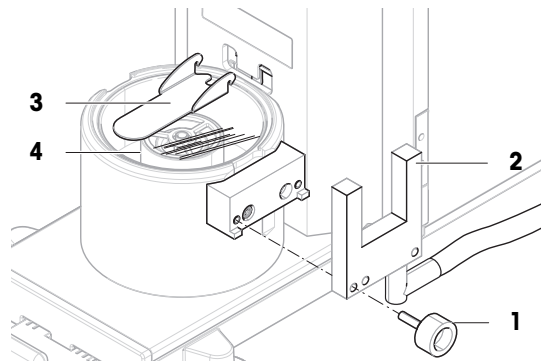

- 4 Remove the centering ring (5).
- 5 Carefully lift and remove the pipetting base (6) with the evaporation trap container (7).

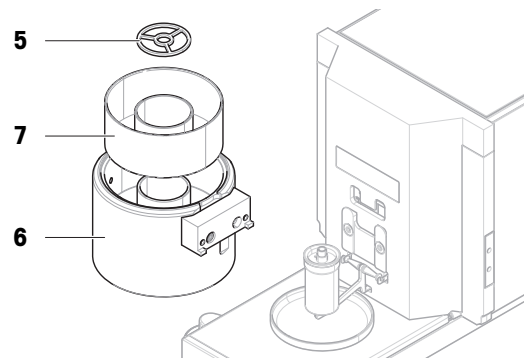

- 6 Remove the pipetting container (8) and unscrew the cover holding the pipetting tube (9).
- 7 Carefully remove the pipetting container support (10).
- 8 Remove the drip tray (11).

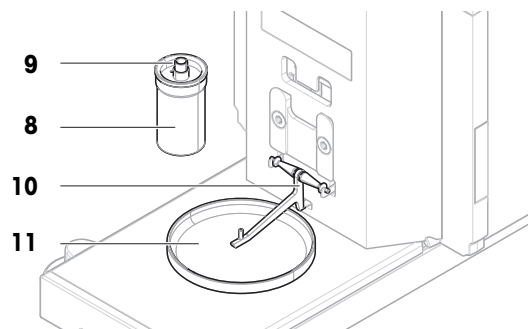

### 7.3.2 Cleaning agents

In the following table, cleaning tools and cleaning agents recommended by METTLER TOLEDO are listed. Pay attention to the concentration of the agents specified in the table.

		Tools				Cleaning agents						
		Paper tissue	Brush	Dishwasher	Water	Acetone	Ethanol (70%)	Isopropanol (70%)	Hydrochloric acid (3-10%)	Sodium hydroxide (0.2-1.0 M)	Peracetic acid (2-3%)	
Around the balance	Balance housing	✓	R	—	R	—	R	✓	R	R	R	
	Feet	✓	R	—	R	—	R	✓	R	R	R	
Balance terminal	Terminal	✓	R	—	✓	PR	R	R	R	R	R	
	Display	✓	—	—	✓	PR	R	R	R	R	R	
	Terminal cover	✓	R	—	✓	—	R	R	R	PR	PR	
Evaporation trap	Evaporation trap container	✓	—	—	✓	PR	R	R	R	R	—	
	Evaporation trap cover (glass)	✓	R	R	R	PR	✓	✓	R	R	R	
	Evaporation trap door	✓	R	R	✓	R	R	R	—	—	—	
Weighing area	Pipetting container	✓	—	—	✓	R	R	R	—	—	PR	
	Pipetting container support	✓	—	—	✓	R	R	R	—	—	—	
	Centering ring	✓	—	—	✓	R	R	R	—	—	—	
	Pipetting base	✓	—	—	✓	R	R	R	—	—	PR	
	Light barrier	✓	—	—	✓	PR	R	R	R	R	—	
	Drip tray	✓	—	—	✓	R	R	R	—	—	PR	

		Paper tissue	Brush	Dishwasher	Water	Acetone	Ethanol (70%)	Isopropanol (70%)	Hydrochloric acid (3-10%)	Sodium hydroxide (0.2-1.0 M)	Peracetic acid (2-3%)
Calibration kit	Weighing pans	✓	—	—	✓	R	R	R	—	—	PR
	Cover ring	✓	—	—	✓	R	R	R	—	—	—
	Draff shield	✓	—	—	✓	R	R	R	—	—	—
Pump	Pump housing	✓	R	—	R	—	R	✓	R	PR	R

### Legend

- ✓ Best recommendation by METTLER TOLEDO; can be used without limitation.
- R Recommended by METTLER TOLEDO; can be used without limitation.
- PR Partially recommended by METTLER TOLEDO: individual resistance to acid and alkali must be evaluated, including dependence to the time exposure.
- Not recommend. High risk for damage.

## 7.3.3 Cleaning the balance



### NOTICE

#### Damage to the instrument due to inappropriate cleaning methods

If liquid enters the housing, it can damage the instrument. The surface of the instrument can be damaged by certain cleaning agents, solvents, or abrasives.

- 1 Do not spray or pour liquid on the instrument.
- 2 Only use the cleaning agents specified in the Reference Manual (RM) of the instrument or the guide "8 Steps to a Clean Balance".
- 3 Only use a lightly moistened, lint-free cloth or a tissue to clean the instrument.
- 4 Wipe off any spills immediately.



For further information on cleaning a balance, consult "8 Steps to a Clean Balance".

► [www.mt.com/lab-cleaning-guide](http://www.mt.com/lab-cleaning-guide)

#### Cleaning around the balance

- Remove any dirt or dust around the balance and avoid further contaminations.

#### Cleaning the terminal

- Clean the terminal with a damp cloth or a tissue and a mild cleaning agent.

#### Cleaning the removable parts

- Clean the removed part with a damp cloth or a tissue and a mild cleaning agent.

#### Cleaning the weighing unit

- 1 Disconnect the balance from the AC/DC adapter.
- 2 Use a lint-free cloth moistened with a mild cleaning agent to clean the surface of the balance.
- 3 Remove powder or dust with a disposable tissue first.



- 4 Remove sticky substances with a damp lint-free cloth and a mild solvent, e.g., isopropanol or ethanol 70%.

### 7.3.4 Cleaning after an overflow

In the event of an overflow, for example when overfilling the pipetting container, excess liquid must be removed immediately.

- 1 Use the pump to empty the evaporation trap container, see [Emptying the evaporation trap container ▶ Page 111].
- 2 Use the pump to empty the pipetting container, see [Emptying the pipetting container ▶ Page 110].
- 3 Disassemble the remaining items and clean them with a lint-free cloth or tissue, see [Disassembling for cleaning ▶ Page 112].
- 4 Reassemble the balance.





#### See also

 Assembling the pump ▶ Page 110

### 7.3.5 Putting into operation after cleaning

- 1 Reassemble the balance.
- 2 Check if the terminal is connected to the balance.
- 3 Reconnect the balance to the AC/DC adapter.
- 4 Check the level status, level the balance if necessary.
- 5 Respect the warm-up time specified in the "Technical Data".
- 6 Perform an internal adjustment.
- 7 Perform a routine test according to the internal regulations of your company. METTLER TOLEDO recommends performing a sensitivity test after cleaning the balance.
- 8 Press **→0←** to zero the balance.  
➔ The balance is ready to be used.

#### See also

-  Technical Data ▶ Page 120
-  Performing an internal adjustment ▶ Page 29
-  Leveling the balance ▶ Page 29
-  Performing a "Sensitivity test" ▶ Page 46

## 7.4 Service

Regular servicing by an authorized service technician ensures reliability for years to come. Contact your METTLER TOLEDO representative for details about the available service options.

## 7.5 Software update

Search for software:

▶ [www.mt.com/labweighing-software-download](http://www.mt.com/labweighing-software-download)

Please contact a METTLER TOLEDO service representative if you need support updating the software.

METTLER TOLEDO recommends saving the data on a storage device before updating the software.

☰ **Navigation:** ▶ **Balance menu** >  **Maintenance** >  **Software update**

#### See also

 Exporting and importing settings ▶ Page 62

### 7.5.1 Updating the software

- A USB storage device containing the software installer (zip file format) is connected to the balance.
- 1 Tap  **Software update**.
- 2 Select **Update software** and tap **→Next**.
  - ➔ An update wizard opens and will lead you step-by-step through the procedure.

### 7.5.2 Restoring the software to the previous version

The current software version can be rolled back to the previous software version.

- 1 Tap  **Software update**.
- 2 Select **Restore the software to the previous version**. and tap **→ Next**.
  - ➔ An update wizard opens and will lead you step-by-step through the procedure.

### 7.5.3 Putting into operation after software update

- 1 Press  to switch on the balance.
  - 2 Check the level status, level the balance if necessary.
  - 3 Perform an internal adjustment.
  - 4 Perform a routine test according to the internal regulations of your company.
  - 5 Press **→0←** to zero the balance.
- ➔ The balance is ready to be used.

#### See also

-  [Leveling the balance ▶ Page 29](#)
-  [Performing an internal adjustment ▶ Page 29](#)

## 8 Troubleshooting

Possible errors with their cause and remedy are described in the following chapter. If there are errors that cannot be corrected through these instructions, contact METTLER TOLEDO.

### 8.1 Error messages

Error message	Possible cause	Diagnostic	Remedy
<b>Balance reset failed</b>	Communication failure	–	Disconnect the power cable and reconnect after a few seconds.
<b>The system has no valid date and time set</b>	Low battery	–	Connect to the power outlet and let the battery charge for two to three days.
<b>Weight cannot be determined</b>	Data signal problems of electronics.	–	Disconnect the power cable and reconnect after a few seconds.
	Bad connection between the terminal and the weighing unit.	Check the cable for damage (kinked, twisted or broken pins).	Replace the terminal cable.
	A device error has occurred.	Check if a device error is listed in the service menu, see [Service menu ▶ Page 87]. Tap <b>Device errors</b> .	Note the error code and contact your METTLER TOLEDO service representative.
<b>Cannot start adjustment</b>	Initial zero was not reached when the balance was switched on.	–	Disconnect the power cable and reconnect after a few seconds.
<b>Preventive performance optimization</b>	The balance memory (RAM) is full.	–	Complete the current task. Disconnect the power cable and reconnect after a few seconds.

#### See also

 Service menu ▶ Page 88

### 8.2 Error symptoms

Error symptom	Possible cause	Diagnostic	Remedy
The display is dark.	The instrument is on standby.	–	Switch on the instrument.
	There is no power.	Check the connection to the AC/DC adapter and the power outlet.	Connect the weighing unit to the power outlet. See "Connecting the balance".
	The terminal is not connected to the instrument.	Check the terminal cable connection.	Connect the terminal cable to the instrument.
	The terminal cable is defective.	Check the cable for damage (kinked, twisted or broken pins).	Replace the terminal cable.
	The wrong AC/DC adapter is connected to the instrument.	Check it, see "Technical Data".	Use the correct AC/DC adapter.

<b>Error symptom</b>	<b>Possible cause</b>	<b>Diagnostic</b>	<b>Remedy</b>
	The AC/DC adapter is defective.	–	Replace the AC/DC adapter.
The value on the display oscillates.	Vibrations on the weighing bench, e.g., building vibrations, foot traffic	Place a beaker with water on the weighing bench. Vibrations cause ripples on the water surface.	Protect the weighing location against vibrations, e.g. with an absorber. Find a different weighing location.
	Draft due to untight draft shield and/or open window.	Check the draft shield for gaps.	Fix the draft shield. Close the window.
	The location is not suitable for weighing.	–	Follow the requirements for the location. See "Selecting the location".
	Something is touching the pipetting container or the weighing pan.	Check for touching parts or dirt.	Remove touching parts. Clean the balance.
The value on the display is drifting towards plus or minus.	The evaporation trap container is empty.	Check if the evaporation trap container contains sufficient water.	Fill the evaporation trap container with water, see "Filling the evaporation trap container".
	There is a water drop on the outside of the pipetting container.	Check if the pipetting container is wet on the outside.	Clean the pipetting container on the outside.
	The pipetted water is warmer or colder than the air inside the evaporation trap.	Check if the weighing result is stable when using acclimatized water.	Bring the water to room temperature.
	The balance has not yet warmed up.	–	Let the balance warm up. Adequate warm-up time is specified in the "General data".
The display shows overload or underload.	The pipetting container is not properly installed.	Slightly lift or press down the pipetting container to see if the weight appears on the display. Check if the pipetting container moves freely.	Install the pipetting container properly, see "Assembling the balance".
	The wrong weighing pan is installed.	Slightly lift or press down the weighing pan to see if the weight appears on the display.	Install the proper weighing pan.
	No weighing pan is installed.	–	Install the proper weighing pan.
	Incorrect zero point at power on.	–	Disconnect the power cable and reconnect after a few seconds.
	The balance is not adjusted.	–	Perform an internal adjustment, see "Internal adjustment".

Error symptom	Possible cause	Diagnostic	Remedy
The evaporation trap door does not open/close when activating the light barrier.	The instrument is on standby.	–	Switch on the instrument.
	The light barrier is not connected to the balance.	Check if the cable is connected.	Connect the cable properly.
	The light barrier is not properly detected by the balance.	–	Disconnect the light barrier cable from the balance. Delete the light barrier from the devices list, see "Deleting a device". Connect the light barrier to the balance.
	The light barrier or the door motor is defective.	Check if the evaporation trap door opens/closes by tapping ↓ on the terminal. If this works, the light barrier is defective. If this does not work, either the light barrier or the door motor is defective.	Replace the light barrier. Contact a METTLER TOLEDO representative to replace the door motor.
The user interface responds slowly.	Too many results are included in the <b>Results list</b> of a task.	Check the <b>Results list</b> of every running and pending task.	Complete all tasks: For each task in the list of <b>Tasks</b> , select the task, tap <b>Continue task</b> , and tap <b>Complete</b> .

### 8.3 Putting into operation after fixing an error

After fixing an error, perform the following steps to put the balance into operation:

- Ensure that the balance is completely reassembled and cleaned.
- Reconnect the balance to the AC/DC adapter.

## 9 Technical Data

### 9.1 General data

#### Power supply

AC/DC adapter (model no. FSP060-DHAN3):

Input: 100 – 240 V AC  $\pm$  10%, 50 – 60 Hz, 1.8 A

Output: 12 V DC, 5 A, LPS, SELV

AC/DC adapter (model no. FSP060-DIBAN2):

Input: 100 – 240 V AC  $\pm$  10%, 50 – 60 Hz, 1.5 A

Output: 12 V DC, 5 A, LPS, SELV

Cable for AC/DC adapter:

3-core, with country-specific plug

Balance power consumption:

12 V DC  $\pm$  10%, 2.25 A

Polarity:



#### Protection and standards

Overvoltage category:

II

Degree of pollution:

2

Standards for safety and EMC:

See Declaration of Conformity

Range of application:

Use only indoors in dry locations

#### Environmental conditions

The limit values apply when the balance is used under the following environmental conditions:

Height above mean sea level:

Up to 5000 m

Ambient temperature:

+10 – +30 °C

Temperature change, max.:

5 °C/h

Relative air humidity:

30 – 70%, non-condensing

Acclimatization time:

At least **8 hours** after placing the instrument in the same location where it will be put into operation.

Warm-up time:

At least **120 minutes** after connecting the balance to the power supply. When switched on from standby, the instrument is ready for operation immediately.

The balance can be used under the following environmental conditions. However, the weighing performances of the balance may be outside the limit values:

Ambient temperature:

+5 – +40 °C

Relative air humidity:

20% to max. 80% at 31 °C, decreasing linearly to 50% at 40 °C, non-condensing

The balance can be disconnected and stored in its packaging under the following conditions:

Ambient temperature:

-25 – +70 °C

Relative air humidity:

10 – 90%, non-condensing

## 9.2 Explanatory notes for the METTLER TOLEDO AC/DC adapter

The certified external AC/DC adapter complies to the requirements for Class II double insulated equipment. It is not provided with a protective earth connection but with a functional earth connection for EMC purposes. This earth connection **is not** a safety feature. Further information about the compliance of our products can be found in the "Declaration of Conformity" delivered with every product.

In case of testing with regard to the European Directive 2001/95/EC, the AC/DC adapter and the instrument have to be handled as Class II double insulated equipment.

Consequently, a grounding test is not required. It is not necessary to carry out a grounding test between the earth connector of the power plug and any exposed part of the metallic housing of the instrument.

Because the instrument is sensitive to static charges, a leakage resistor of 10 k $\Omega$  is connected between the earth connector (1) and the negative pole (2) of the AC/DC adapter. The arrangement is shown in the equivalent circuit diagram. This resistor is not part of the electrical safety arrangement and does not require testing at regular intervals.

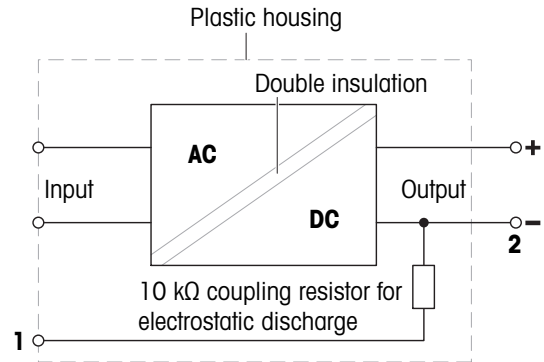

### 9.3 Model-specific data

	<b>XPR26PC</b>
--	----------------

#### Limit values

Capacity	22 g
Nominal load	20 g
Readability	0.001 mg
Repeatability (at nominal load)	0.0025 mg
Repeatability (at 5% load)	0.0015 mg
Linearity deviation	0.01 mg
Sensitivity offset (at nominal load) ▲	0.08 mg
Sensitivity temperature drift	0.0001%/°C

#### Typical values

Repeatability (at 5% load)	0.0007 mg
Linearity deviation	0.003 mg
Eccentricity deviation (at test load)	0.006 mg (10 g)
Sensitivity offset (at nominal load) ▲	0.05 mg
Minimum weight (USP, tolerance = 0.10%) ▼	1.4 mg
Minimum weight (tolerance = 1%) ▼	0.14 mg
Settling time	3.5 s

#### Dimensions and other specifications

Balance dimensions (W × D × H)	195 × 485 × 292 mm
Balance weight	10.1 kg

#### Weights for routine testing

Weights (OIML class)	20 g (F1) / 1 g (F1)
Weights (ASTM class)	20 g (ASTM 1) / 1 g (ASTM 1)

▲ after adjustment with internal weight

▼ determined at 5% load, k = 2



## 9.4 Dimensions

Models: XPR26PC

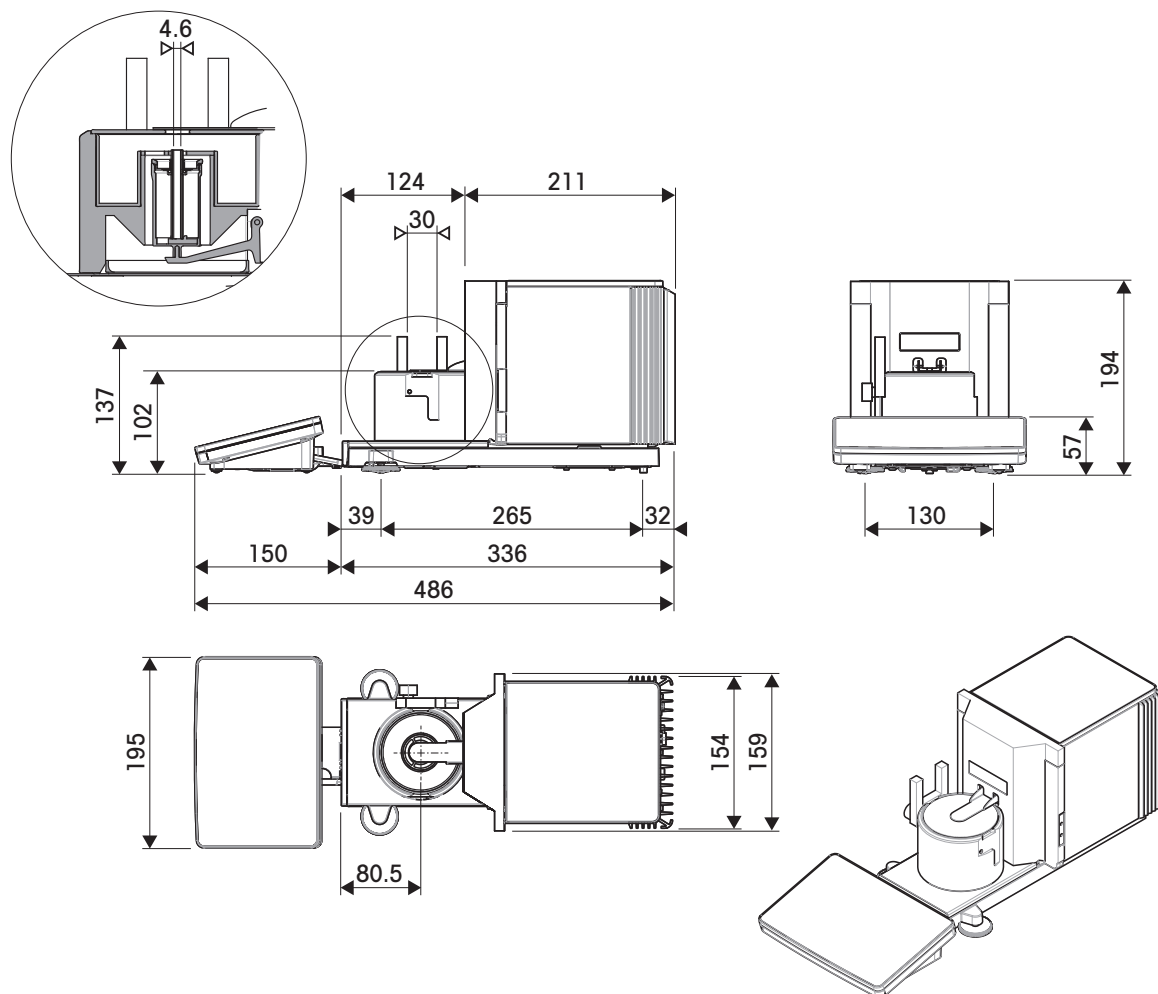

	Outer dimensions [mm]
	Clear dimensions [mm]

## 10 Disposal

In conformance with the European Directive 2012/19/EU on Waste Electrical and Electronic Equipment (WEEE) this device may not be disposed of in domestic waste. This also applies to countries outside the EU, per their specific requirements.

Please dispose of this product in accordance with local regulations at the collecting point specified for electrical and electronic equipment. If you have any questions, please contact the responsible authority or the distributor from which you purchased this device. Should this device be passed on to other parties, the content of this regulation must also be related.





## 11 Accessories and Spare Parts

### 11.1 Accessories

Accessories are additional components that could help you in your workflow.

	Description	Order no.
<b>Pipette calibration</b>		
	Calibration kit (without adjustment/test weights)	11140044
	Reagent reservoirs, 5 pcs.	11600616
	Barometer	11600086
	Calibrated Thermometer	11132685
<b>Antistatic kits</b>		
	Compact ionizer with stand (USB)	30499859
	Additional compact ionizer (USB) for Compact ionizer with stand (30499859)	30496446
<b>Printers</b>		
	CLS-631 label printer (RS232C/USB-A) Label and ink ribbon kit The NetCom Kit might be needed for this printer. Contact your local METTLER TOLEDO service representative.	11141820 30004309

	P-52RUE dot matrix printer RS232C, USB and Ethernet connections, simple print-outs	30237290
	Paper roll (length: 20 m), set of 5 pcs	00072456
	Paper roll (length: 13 m), self-adhesive, set of 3 pcs	11600388
	Ribbon cartridge, black, set of 2 pcs	00065975
	P-56RUE thermal printer with RS232C, USB and Ethernet connections, simple print-outs, date and time	30094673
	Paper roll, white (length: 27 m), set of 10 pcs	30094723
	Paper roll, white, self-adhesive (length: 13 m), set of 10 pcs	30094724
	P-58RUE thermal printer with RS232C, USB and Ethernet connections, simple print-outs, date and time, label printing, balance applications, e.g., statistics, formulation, totaling	30094674
	Paper roll, white (length: 27 m), set of 10 pcs	30094723
	Paper roll, white, self-adhesive (length: 13 m), set of 10 pcs	30094724
	Paper roll, white, self-adhesive labels (550 labels), set of 6 pcs	30094725
	Dimension of the label 56×18 mm	

### Anti-theft devices

	Anti-theft cable with lock	11600361
--	----------------------------	----------

### RFID readers / writers / cards

	EasyScan USB Reads and writes RFID tags.	30416173
	Smart Tag	
	Set of 50 pieces	30101517
	Set of 200 pieces	30101518
	MethodCard	
	Set of 5 pieces	30300929
	Set of 25 pieces	30300930

### Hands-free accessories

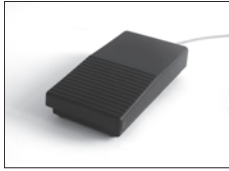

Foot switch, optional switch for remote operation (USB connection)

30312558



ErgoSens, optical sensor for remote operation (USB connection)

30300915

### Barcode readers



Corded USB barcode reader

30417466

### Cables for RS232C interfaces



USB-RS232 cable (to connect the instrument via RS232C to a USB port)

64088427



USB-RS232 cable with integrated null modem to connect peripherals and computers via RS232C to an XPR/XSR balance

30576241

### Wireless interfaces



Bluetooth RS232C serial adapter ADP-BT-S

30086494

For wireless connection between:

- instrument and computer (depending on the instrument model)
- printer and instrument



Bluetooth USB adapter for wireless connection to P-5x printer (additional Bluetooth RS232 serial adapter 30086494 required)

30416089

## Weighing tables



Weighing table

30404636

## Software



Calibry PC Software

Calibry Express; for single channel pipettes

11138423



Calibry Single workstation; for calibration with one system MPC

11138419



Calibry Network; Installation on several PC of the network accessing the same database

11138420

## CarePacs



CarePac OIML

30550617



CarePac ASTM

11123106

## Adjustment weights



OIML / ASTM Weights (with calibration certificate)

► [www.mt.com/weights](http://www.mt.com/weights)

## Various



EasyHub USB

30468768



Terminal cable, extended, length: 4.5 m

30300920

## 11.2 Spare parts

Spare parts are parts that are delivered with the original instrument but that can be replaced, if needed, without the help of a service technician.

### 11.2.1 Balance

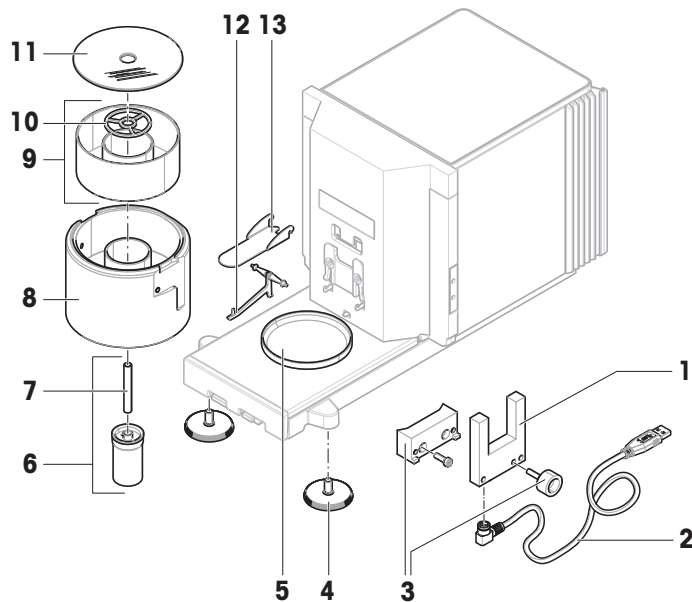

	Order no.	Designation	Remarks
1	30521637	Light barrier	–
2	30460312	Cable light barrier	–
3	30521728	Fixing screw and spacer light barrier	–
4	30460287	Leveling feet, set	Including: 2 leveling feet
5	30521632	Drip tray	–
6	11107917	Pipetting container	Including: Pipetting tube
7	30521634	Pipetting tube	Material: glass
8	30521729	Pipetting base	–
9	30521635	Evaporation trap container	–
10	30538437	Centering ring	–
11	30521636	Evaporation trap cover	Material: glass
12	30521633	Support pipetting container	–
13	30460313	Evaporation trap door	–



## 11.2.2 Pump

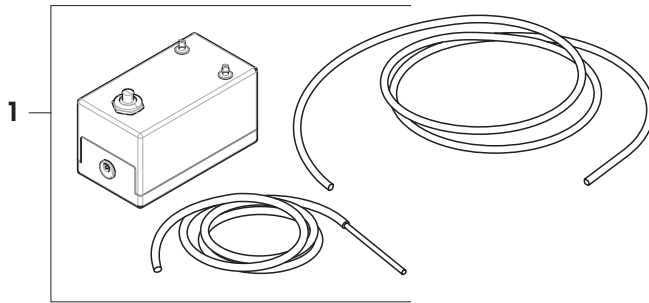

	<b>Order no.</b>	<b>Designation</b>	<b>Remarks</b>
<b>1</b>	30676828	Suction pump	Including: 1 tubing with metallic tube, 1 tubing without tube

### 11.2.3 Miscellaneous

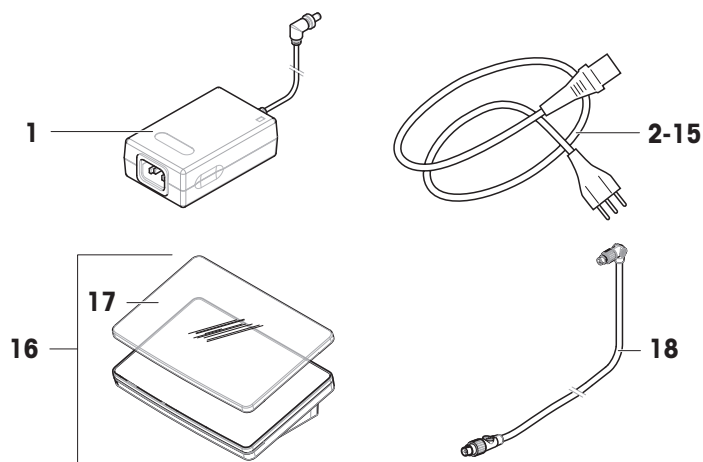

	Order no.	Designation	Remarks
<b>1</b>	30388323	AC/DC adapter	Output: 12 V DC, 5 A
<b>2</b>	88751	Power cable AU	—
<b>3</b>	30015268	Power cable BR	—
<b>4</b>	87920	Power cable CH	—
<b>5</b>	30047293	Power cable CN	—
<b>6</b>	87452	Power cable DK	—
<b>7</b>	87925	Power cable EU	—
<b>8</b>	89405	Power cable GB	—
<b>9</b>	225297	Power cable IL	—
<b>10</b>	11600569	Power cable IN	—
<b>11</b>	87457	Power cable IT	—
<b>12</b>	11107881	Power cable JP	—
<b>13</b>	11107880	Power cable TH, PE	—
<b>14</b>	88668	Power cable US	—
<b>15</b>	89728	Power cable ZA	—
<b>16</b>	30134389	Terminal PRAT	Including: protective cover
<b>17</b>	30125377	Protective cover, terminal	For terminal (PRAT, PRPT)
<b>18</b>	30416123	Cable, terminal	—

## 11.2.4 Packaging

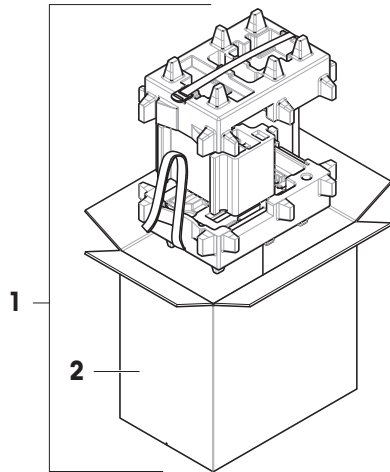

	<b>Order no.</b>	<b>Designation</b>	<b>Remarks</b>
<b>1</b>	30460297	Packaging	Including: Export box, inner protection material
<b>2</b>	30460298	Export box	Excluding: Inner protection material

## 12 Appendix

### 12.1 Approved balances

#### 12.1.1 Definitions

##### Approved balances

Approved balances are balances that are subject to the local, legal requirements of "non-automatic weighing instruments", as defined in OIML R76. For approved balances, the net weighing results must comply with a higher level of control. Approved balances are used, for example, for legal metrology, for weight-based trading, or for determination of mass for the application of laws. The term "approved balance" includes legal-for-trade (LFT) balances, certified balances, and registered balances.

The restrictions and special behaviors of these balances are described in the present section as well as in specific balance settings throughout the manual.

To identify approved balances, the characters /M or /A are appended to the model names.

##### Actual scale interval, **d**

The value **d** represents the "actual scale interval". According to OIML R76-1 [T.3.2.2], it represents the difference between two consecutive indicated values. In some countries, the value **d** is defined as the "scale division" or the "scale division interval". In practice, it is often referred to as the "readability".

##### Verification scale interval, **e**

The value **e** represents the "verification scale interval" [OIML R76-1: T.3.2.3]. This value is used for the classification and verification of an instrument. It represents the absolute accuracy of the instrument and is relevant in the context of market surveillance.

The minimum value of the verification scale interval is 1 mg. [OIML R76-1: 3.2]

#### 12.1.2 Descriptive markings

The descriptive markings of the instrument are on the model label, according to OIML R76-1 [7.1.4]:

- **Min**: minimum capacity
- **Max**: maximum capacity (referred to as "capacity" in this document)
- **e**: verification scale interval
- **d**: actual scale interval

The type label also contains those descriptive markings, as well as other metrological characteristics and limits of the instrument.

#### 12.1.3 Restrictions on zeroing and taring

##### Zeroing the balance

- When switching on the balance, an initial zero is performed. If the load is more than 20% of the balance capacity during the initial zero, the zeroing is not possible and no weighing value is displayed. [OIML R76-1: T.2.7.2.4 and 4.5.1]
- During operation, the range for which a zero can be performed is  $\pm 2\%$  of the balance capacity. [OIML R76-1: 4.5.1]

##### Taring the balance

- It is not possible to tare the balance if the gross weight is negative. [OIML R76-1: 4.6.4]

#### 12.1.4 Factory method: General Weighing

All balances are delivered with a factory method named **General Weighing**. For approved balances:

- The factory method cannot be deleted.
- The unit of the factory method **General Weighing** is set to **g** and cannot be edited.

- When switching on the balance, the factory method is shown on the weighing screen, regardless of which method was running when the balance was switched off.
- For the tolerance profile used by the factory method, the setting **Display readability** is set to **1d** and cannot be edited.

### 12.1.5 Representation of weighing results

The representation of weighing results from approved balances follows rules with respect to the weighing units, the weight value, and the indicator of the type of weight. These rules are described in the following paragraphs.

#### Unit

- A reduced set of units is available for selection.
- Units defined by the user (**Custom unit**) are restricted to characters that cannot be confused with other standard units. The following values are not allowed (uppercase and lowercase letters):
  - all common units, abbreviation or full name, for example, g, gram, kg, ct, oz, etc.
  - c, ca, car, cm, crt, cart, kt, gr, mgr, ugr, kgr, gra, mgra, ugra, kgra, grm, mgrm, ugrm, kgrm, mgram, ugram, kgram, k, kilo, to, tn, sh, tael, dram, dr, lboz, gramme, tonne, livre, once, lbt, cwt, dwt
  - all common units starting with the letter "o", where the "o" is replaced by the number "0", for example, Oz, Ozt, etc.
  - all common units where the letter "s" is added at the end

#### Weighing result

If the actual scale interval is smaller than the verification scale interval ( $d < e$ ), the digits that are smaller than **e**, are called non-verified digits. For balances showing up to four digits ( $d \geq 0.1$  mg), the non-verified digits are marked. For example, a weight of 100 mg placed on a balance with  $e = 1$  mg and  $d = 0.1$  mg would be printed as 100.[0] mg. [OIML R76-1: 3.4.1, 3.4.2]

- primary weight value on the main weighing screen: the non-verified digits are grayed out
- secondary weight value (**Info weight**) on the main weighing screen: the non-verified digits are grayed out
- **Results list**, detailed view: the non-verified digits are in brackets
- **Alibi memory**: the non-verified digits are in brackets
- Printout: the non-verified digits are in brackets
- Data export: no special marking

If custom units are used, the non-verified digits are not marked.

The depiction of the weight values does not affect the accuracy of the weighing results. That is consistent with legal metrology requirements.

#### Indicator for weighing result

The type of weighing result, such as **Net weight**, **Tare weight**, or **Gross weight**, is marked according to OIML R76-1 [T.5.2, T.5.3, 4.6.5, 4.6.11, 4.7].

Indicator	Main weighing screen	Results list	Printout
<b>Net weight</b>	Net	<b>Net weight</b>	<b>N</b>
<b>Tare weight</b>	–	<b>Tare weight</b>	<b>T</b>
<b>Preset tare weight</b>	–	<b>Preset tare weight</b>	<b>PT</b>
<b>Gross weight</b>	–	<b>Gross weight</b>	<b>G</b> <sup>1</sup>
Calculated weight	*	*	*
Unstable weight	o	<b>D</b>	<b>D</b>

<sup>1</sup> If only the gross weight is included on the printout, the indicator **G** is omitted.

### Printout examples

The following examples refer to a balance with **e** = 1 mg and **d** = 0.1 mg. The tare or preset tare value is 200 mg, the gross weight is 743.2 mg and the net weight is 543.2 mg.

- with manual tare:

N	543. [2] mg
T	200. [0] mg
G	743. [2] mg

- with preset tare:

N	* 543. [2] mg
PT	200.0 mg
G	743. [2] mg

### 12.1.6 MT-SICS

The following commands are not available for approved balances:

- **C0**
  - It is not possible to change the adjustment type.
- **TI**
  - It is not possible to do an immediate tare. [OIML R76-1: 4.6.8]
- **ZI**
  - It is not possible to do an immediate zero. [OIML R76-1: 4.5.6]

### 12.1.7 Reference

OIML R 76-1 Edition 2006 (E), Non-automatic weighing instruments, Part 1: Metrological and technical requirements – Tests

# Index

## A

---

AC/DC adapter	120, 121
acclimatization	
time	28, 120
adjustment	19, 48
calibration kit	49
external	49
internal	48
setting	106
altitude	120
approved balance	134
assemble	
balance	26
pump	110

## B

---

balance information	73
barcode reader	85
delete	56
block	
balance	67
Bluetooth	84
printer	52, 85
brightness	81

## C

---

calibration kit	45, 46, 49
function check	29
weighing pan	43
certified balance	
see approved balance	134
clone	
method	39
combined test weight	41
command	
MT-SICS	58, 86
web service	59, 86
compliance information	8
container	
empty	110
evaporation trap	14, 111
install	26
pipetting	13, 110
convention	7

create	
method	36
repeatability test	42
sensitivity test	42
user	65
user group	65

## D

---

delete	
device	56
method	39
RFID reader	56
task	39
device	
barcode reader	85
delete	56
edit setting	56
ErgoSens	56, 86
foot switch	86
light barrier	14, 27, 85
peripheral	85
printer	50, 51, 52, 85
RFID reader	54, 68, 85
disposal	124
door	
open	14, 15
dosing head	
copy data	69
data fields	69
edit data	68
drip tray	14

## E

---

EasyScan	
see RFID reader	54
edit	
method	38
empty	
evaporation trap	111
pipetting container	110
pump	110
environmental condition	22, 120
ErgoSens	56, 86
delete	56
Ethernet	84
EULA	28

evaporation trap	14	level	
empty	111	balance	29
fill	31	indicator	17
install	26	leveling aid	29, 71
external		leveling feet	14
adjustment	49	leveling aid	29, 71
device	85	leveling feet	14
<b>F</b>		LFT balance	
fill		see approved balance	134
evaporation trap	31	light	
foot switch	86	barrier	14, 27, 85
delete	56	StatusLight	81
function check	29	location	22
<b>G</b>		log in	28, 67
general weighing		log out	67
create a method	37	<b>M</b>	
perform	37	main weighing screen	17
setting	88	method	18
<b>H</b>		clone	39
history	71	create	36
humidity	120	delete	39
evaporation trap	14	edit	38
<b>I</b>		perform	36
install		type	36
balance	26	MT-SICS	58, 86
ErgoSens	56	<b>O</b>	
light barrier	27	optical sensor	
printer	50, 52	light barrier	14, 27, 85
pump	110	overflow	
put into operation	27	clean	115
RFID reader	54	overview	
site	22	balance	13
terminal	25	terminal	15
interface		type label	16
Bluetooth	84	<b>P</b>	
Ethernet	84	pack	
internal		balance	33
adjustment	48	password	
<b>L</b>		log in	28
LabX	57, 86	new user	65
legal-for-trade balance		reset	66
see approved balance	134	perform a method	
		general weighing	37
		pipetting container	13
		empty	110



install	26	software	
power supply		version	7
see AC/DC adapter	120	sound	
pressure		terminal	81
pump	70	standby	15, 30, 31
print		StatusLight	15, 81
result	50, 52	store	
test page	51, 53	balance	33
printer	50, 51, 52, 85	switch on/off	28, 31
delete	56	symbol	7
install	50, 52	warning	10
test	51, 53	<b>T</b>	
pump		tare	15, 32
assemble	110	task	39
empty container	110, 111	temperature	120
pressure	70	acclimatization time	120
<b>R</b>		warm-up time	120
repeatability test	45	terminal	15
create	42	brightness	81
setting	100	install	25
reset		overview	15
password	66	sound	81
RFID		StatusLight	81
reader	54, 68, 85	test	18, 41
Smart Tag	54	calibration kit	41, 45, 46
tag	68	create	42
<b>S</b>		prepare	42
safety information	10	repeatability	45
sensitivity test	46	sensitivity	46
create	42	setting	100
setting	103	test weight	40, 41
sensor		setting	99
light barrier	14, 27, 85	time	
service		acclimatization	28, 120
LabX	57, 86	warm up	28, 120
MT-SICS	58, 86	transport	
web	59, 86	long distance	33
setting		short distance	33
adjustment	106	type label	
general weighing	88	overview	16
repeatability test	100	<b>U</b>	
sensitivity test	103	unblock	
test	100	balance	68
Smart Tag	54	unpack	
SmartTrac	17	balance	22

USB	
printer	50, 85
see device	85
user	
create	65
delete	65
group	65
management	64
name	28

## **W**

---

warm up	
time	28, 120
warning symbol	10
web service	59, 86
weighing aid	
SmartTrac	17
weighing pan	
calibration kit	43, 45, 46, 49
weighing screen	17
weight	
test weight	40

## **Z**

---

zero	15, 31
------	--------



# GWP®

Good Weighing Practice™

---

GWP® is the global weighing standard, ensuring consistent accuracy of weighing processes, applicable to all equipment from any manufacturer. It helps to:

- Choose the appropriate balance or scale
- Calibrate and operate your weighing equipment with security
- Comply with quality and compliance standards in laboratory and manufacturing

 [www.mt.com/GWP](http://www.mt.com/GWP)

[www.mt.com/pipcal](http://www.mt.com/pipcal)

For more information

**Mettler-Toledo GmbH**

Im Langacher 44  
8606 Greifensee, Switzerland  
[www.mt.com/contact](http://www.mt.com/contact)

Subject to technical changes.  
© 08/2022 METTLER TOLEDO. All rights reserved.  
30419865C en



30419865